

UT Health Standard Specifications

TABLE OF CONTENTS

00 OWNERS SPECIAL CONDITIONS
00 73 16 PROJECT INSURANCE_SPEC ONLY
01 31 00 PROJECT ADMINISTRATION
01 32 00_PROJECT_PLANNING__SCHEDULING.....
01 35 23_PROJECT_SAFETY_REQUIREMENTS
01 45 00_PROJECT_QUALITY_CONTROL.....
01 57 23_TEMPORARY STORM WATER POLLUTION CONTROL.....
01 60 00 PRODUCT REQUIREMENTS.....
01 77 00_PROJECT_CLOSEOUT_PROCEDURES
01 91 00 GENERAL COMMISSIONING REQUIREMENTS
10 14 16.11 BUILDING PLAQUE

PART 1 - GENERAL

1.1 PURPOSE

- 1.1.1 These Special Conditions are in addition to the requirements of the Uniform General Conditions for University of Texas System Building Construction Contracts (UGC), and are a part of the Contract Documents.
- 1.1.2 Terms and conditions set forth in this document are for the Contractor only, and are valid regardless of the project delivery method. For Construction Manager at Risk or Design-Build, the final version of the document shall be confirmed by the Owner, and included by the Construction Manager or Design-Build Contractor in the Guaranteed Maximum Price Proposal.

1.2 SEPARATE CONTRACT

- 1.2.1 As provided in the UGC, the Owner may award other contracts for other portions of the Project. Additional separate contracts may include, but are not limited to, commissioning, geotechnical, surveying services, furnishings procurement, furnishings installation, equipment installation, fire alarm certification, HVAC test and balance services, construction materials testing and envelope and waterproofing.

1.3 PREVAILING WAGE RATE DETERMINATION

- 1.3.1 In accordance with the UGC, the attached schedule identifies the Prevailing Minimum Wage Rate determination for Houston/Galveston Area. Refer to "Attachment A."
- 1.3.2 The Owner may verify wage rate compliance in the field by interviewing workers. The Contractor shall assist the Construction Inspector (CI) with this task, including providing translation for non-English speaking workers.

1.4 RELATED DOCUMENTS

In addition to specific references indicated herein, the Contractor's attention is specifically directed, but not limited, to the following Sections and Documents, which include additional administrative requirements.

- 1.4.1 Provisions established within the Uniform General Conditions for University of Texas System Building Construction Contracts (UGC), all Sections of Division 1 - General Requirements, other applicable Sections of all Divisions of Specifications, and the Drawings are collectively applicable to this Section. In the event of conflict between specific requirements of the various documents, the more restrictive, the more extensive (i.e. more expensive) requirement shall govern.
 - 1.4.1.1 Effective February 1, 2008, all references within the UGC to the Texas Workers Compensation Commission shall be revised to the Texas Department of Insurance, including all subsequent acronyms.
- 1.4.2 "Attachment A" (To Special Conditions): Prevailing Wage Rate Determination.
- 1.4.3 "Attachment B" (To Special Conditions): Project Sign.
- 1.4.4 "Attachment C" (To Special Conditions): Weather Days.

PART 2 – PRODUCTS

2.1 OWNER'S SPECIAL CASH ALLOWANCES

Owner's Special Conditions



The University of Texas
Health Science Center at Houston

A total Owner's Special Cash Allowance of \$150,000 shall be included in the Contractor's base proposal amount, to cover expenses identified below. The Contractor shall confirm the costs and inform the Owner at least 30 calendar days prior to purchase or payment. The Contractor shall be reimbursed through a reduction in the scheduled Owner's Special Cash Allowance amount below in accordance with the UGC.

2.1.1.1 The Owner is exempt from paying for permits and fees to local government entities related to work on the Owner's property. There shall be no building permit required, no platting fees, and no local government inspection fees for permanent work on the Owner's property. The Owner is not exempt from permits and fee requirements for work in public rights-of-way or outside the boundaries of the Owner's property.

2.1.1.1.1 For permanent improvements or utility service when permits, governmental or utility company inspections or related fees are required, it is anticipated that such a fee shall be necessary for **TBD**.

2.2 ANIMALS AND LIVESTOCK

2.2.1 Animals including, but not limited to, personal pets and livestock, are prohibited from the Project site, except assistance animals as defined by the Americans with Disabilities Act 28 CFR § 36.104 and Texas Human Resources Code, Title 8, Chapter 121. Modifications and adjustments to the work environment will be considered by the Owner for contracted work force that require or utilize animal assistance to address limitations associated with a recognized disability. The Contractor shall submit the written request to the Owner's Designated Representative (ODR) and shall demonstrate appropriate monitoring measures for control in the Project Safety Plan.

2.3 TEMPORARY FIELD OFFICE STRUCTURES, FURNISHINGS, AND EQUIPMENT

2.3.1 Unless otherwise agreed to by the Owner, temporary field office(s) shall be provided and maintained for the duration of the construction phase (from Notice to Proceed until at least Substantial Completion) and removed only after concurrence from the Owner's Designated Representative.

2.3.2 Temporary field office(s) shall have adequate and safe entry, including steps with railings and landings or stoops as appropriate, and shall provide hard, non-slip surface walkways to connect the field office structures to one another and to site entry or exit.

2.3.3 The Contractor shall provide field office(s) and storage sheds/trailers/accommodations as necessary for the major subcontractors to adequately perform their respective work.

2.3.3.1 All storage sheds/trailers shall be secure and weather tight for the storage of tools and all materials, which may be damaged by the weather. All storage sheds floors shall be raised at least 6 inches above grade.

2.3.4 Contractor's Temporary Field Office:

2.3.4.1 The Contractor shall coordinate and direct the work of the Project from the Project site.

2.3.4.2 The Contractor shall provide and maintain at least one temporary field office that is adequately staffed, furnished, and equipped.

2.3.4.3 Conference areas shall include at least one primary area suitable for up to 15 persons to participate in Project progress and coordination meetings. The walls of this conference area are to serve as display surfaces for maintaining current project photos, color boards, prints of project schedules, work placement plans, etc.

2.3.5 Owner's Temporary Field Office(s)

- 2.3.5.1 The Contractor shall provide and maintain at least one (1) **new** (not refurbished), secure, weather tight, well-lighted, air-conditioned, and heated Owner's temporary field office(s) as approved by the Owner's Designated Representative (ODR) for the duration of the project from the Notice to Proceed for Construction to at least Substantial Completion. The temporary field office shall be removed only after concurrence from the ODR.
- 2.3.5.1.1 The office(s) shall include provisions for telephones, facsimile machines, Internet connection services, conference area(s), functioning toilet facilities, and maintenance of all Project files.
- 2.3.5.2 The Owner's temporary field office shall measure a minimum of 11 feet 8 inches wide and 52 feet long, partitioned to provide for three separate work areas including two entry doors with keyed locks, a storage closet, a TAS accessible restroom and a "service counter" (at least a 3'-0" in length with sink).

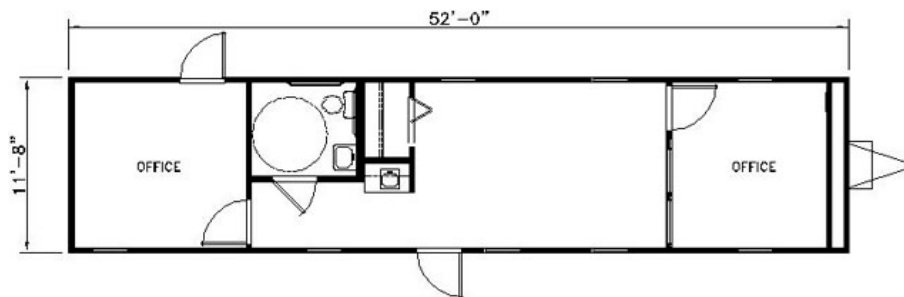

- 2.3.5.3 The Contractor shall lease and furnish the Owner's temporary field office with the following new furniture and equipment on behalf of the Owner:
- 2.3.5.3.1 One 42 inches x 72 inches layout table
 - 2.3.5.3.2 One conference table, including at least 15 chairs
 - 2.3.5.3.3 One plan storage area capable of holding 30 sets of full size drawings
 - 2.3.5.3.4 Three five-high vertical or lateral legal size filing cabinets
 - 2.3.5.3.5 One 36 inches x 72 inches double pedestal desk with an ergonomic chair with casters for each office
 - 2.3.5.3.6 One 36 inches wide x 28 inches high bookcase with adjustable shelf for each office
 - 2.3.5.3.7 One two-drawer file cabinet for each office
- 2.3.5.4 The Contractor shall provide Internet connectivity at a minimum of 20 megabits per second (Mbps) for offices of 1-9 employees (40 Mbps for offices of 10-19 employees, and so forth). The prescribed minimum connection speed applies to both upstream and downstream directions, and must not be shared with other entities (e.g., contractor computers) or devices such as telephones (excluding telephones). Where such sharing is necessary, additional bandwidth must be provided so that the prescribed minimums for employee computers are met. Connectivity must be provided in the form of a 10/100-base-T Ethernet handoff. For offices of at least 5 UTHSC employees a single static IP from the ISP is required, which will be used with a UT System-provided router and switch to provide seamless connectivity to the UT System network via an IPSEC tunnel. For offices of 1-4 UTHSC employees it is acceptable to have the ISP provide DHCP IP's



The University of Texas
Health Science Center at Houston

directly to UTHSC computers, in which case an Ethernet switch with at least 4 user ports shall be provided by the contractor, and UTHSC employees will use UT System-provided tools (e.g. software VPN, terminal server, Outlook Web Access, etc.) to provide connectivity to the UT System network. In addition, the Contractor shall provide wireless connection services for the Owner anywhere within the project construction fence using wireless router(s) and other equipment conforming to the 802.11n standard as set by IEEE or the most currently available wireless standard.

- 2.3.5.5 The Contractor shall provide the following additional office and technology equipment as approved by the Owner:
 - 2.3.5.5.1 The Contractor will provide one new digital copier/scanner/networked printer (115 volt / 15 amp) with a minimum copy speed of 30 pages per minute, automatic document feeder, auto duplex, collator, two standard paper trays (one of which supports 11 inches x 17 inches paper), scanner (including pdf, tiff, jpg file formats), and fax with monthly service agreement, including supplies, paid by the Contractor.
 - 2.3.5.5.1.1 Printer capability shall include black & white and color printing; minimum print speed of 26 ppm black & white; scan with a minimum of 1200 x 2400 dpi scan resolution; and 600 dpi black and white and 4800 x 1200 dpi color printing capability.
 - 2.3.5.5.2 Three office telephones, each equipped with voicemail and conferencing features.
- 2.3.5.6 The Contractor shall provide weekly janitorial services for Owner's temporary field office(s), including supplying and servicing of toilet facilities.
- 2.3.5.7 The Contractor shall provide and maintain a coffee station in the Owner's temporary field office, including supplying all consumables.
- 2.3.5.8 Contractor shall provide to the Owner all equipment equivalent to the equipment being used in the field.
 - 2.3.5.8.1 The Contractor shall provide an internet connection capable of at least 100 megabits per second simultaneously in both upstream and downstream directions, with a standard RJ45 copper or fiber Ethernet handoff connection for UT System Administration networking equipment. Contractor will also provide internet service in the form of one routable statically-assigned IP address with no restrictions place on types of traffic passed and a secure location for a network switch appliance with access to an appropriate power receptable. Where this connection or service is unavailable, Contractor will supply a 4G/LTE or better internet service with a supplied router appliance allowing UT personnel to connect a network switch for multiple personnel.
 - 2.3.5.8.1.1 For Information Only: Once Internet connectivity is established, the UTHSC Administration – Office of Technology and Information Systems (OTIS) will provide a method for employees to connect to the UTHSC network. Software, router-to-router, or site-to-site VPN will be used depending on the needs of employees and any limitations imposed by the ISP (this may be a commercial Internet Service Provider or a UT System institution). OTIS will provide, install and support standard configuration desktop or laptop devices as required by the Owner's personnel officing on site. These machines will comply with UT System UTS165 Information Resources Use and Security Policy (<http://www.utsystem.edu/policy/ov/uts165.html>) and the Information



The University of Texas

Health Science Center at Houston

Resources Security Operations Manual of UT System Administration
(<http://www.utsystem.edu/systempolicies/infosecurityoperationsmanual.pdf>).

- 2.3.5.8.2 For a construction trailer with more than 10 people, provide at least 10.0 megabits per second simultaneously in both upstream and downstream directions.

2.4 PROJECT FENCING

- 2.4.1 The Contractor and Subcontractors shall confine their activities to the Project Site and in no way obstruct any other part of the campus or utilize any campus facilities for any purpose.

- 2.4.1.1 Upon mobilization, the Contractor shall build a substantial wire mesh fence at least 6 feet high with top rails as shown on the Site Plan, completely surrounding the site. Posts shall be placed not more than 8 feet apart and securely set in the ground. Wire mesh shall be tightly stretched over the supports and attached at the top rail.

- 2.4.1.2 The Project site fencing shall include Emergency Service and trucking gates in locations shown on the Site Plan. The gates shall be hung with heavy strap hinges and hasps for locking. Fences and gates shall be properly maintained until Substantial Completion, and only removed with concurrence from the Owner.

2.5 PROJECT SIGNAGE

- 2.5.1 The Contractor shall construct and erect one Project sign on the Project site in a location designated by the Owner. The sign shall be constructed as instructed by the Owner. Refer to Attachment "B."

- 2.5.2 The Contractor shall submit a 1/4" = 1'-0" scale shop drawing of the sign, including all lettering, to the Owner for approval prior to installation. The sign shall remain the property of the Owner. Upon project completion, the Contractor shall remove the sign and deliver it to a location designated by the Owner.

- 2.5.3 Additional Contractor or Subcontractor signs or advertisements shall not be permitted without the Owner's written approval. Corporate logos and artwork are prohibited.

2.6 TEMPORARY PROJECT WATER

- 2.6.1 The Contractor shall provide temporary lines for all water required during the Project and shall make arrangements with the Owner's Utility Department for water service. This shall include all means of conveying and the necessary metering devices. In lieu of temporary connections, the Contractor may make permanent connections and such may serve for the construction period.

- 2.6.2 In the event water is not available at the Project site from the Owner's existing distribution system, the Contractor shall negotiate with the local distributor for water and pay all fees and rates required by the local Water Department.

- 2.6.3 The Contractor shall pay all costs related to providing and installing temporary construction water, except water utility charges (if Owner-provided).

2.7 TEMPORARY PROJECT POWER AND LIGHTING

- 2.7.1 The Contractor shall make arrangements with the local Utility Company for temporary construction power. If power is available only through the Owner's system, the Contractor shall provide metering equipment and extend temporary power to the site, even if the monthly consumption is paid by the Owner. The Contractor may energize the permanent power system in the building only with prior written approval from the Owner. The Contractor shall provide adequate ground fault interruption (GFI) protection and a main disconnect panel at the point of connection to the Owner's

system.

2.7.2 The Contractor shall provide adequate lighting about the site for security, inspections of excavations, and if night shift work occurs. The Contractor shall also provide adequate temporary interior lighting throughout the building enclosure to facilitate quality workmanship and appropriate inspection conditions.

2.7.3 The Contractor shall pay all costs related to providing and installing temporary construction power and lighting, except electric utility charges (if Owner-provided).

2.8 TEMPORARY PROJECT MECHANICAL SERVICES

2.8.1 If temporary heat is required for the installation or protection of the work, the Contractor shall provide heating and proper ventilation in such a manner that no work shall be damaged.

2.8.2 After the mechanical equipment has been connected to the local chilled water and steam distribution systems, the equipment may be operated by the Contractor to heat and cool the building if automatic controls have been activated to limit thermal usage as deemed acceptable to the Owner.

2.8.3 During operation of the mechanical equipment, prior to achieving Substantial Completion, the Contractor shall keep the mechanical equipment in good operating condition, properly maintained, including cleaning and changing of all filters. New, non-construction filters shall be installed prior to the Owner's acceptance of the mechanical equipment. The warranty period for the equipment shall start on the Substantial Completion date.

2.8.4 The Contractor shall pay for all costs related to temporary project mechanical services.

2.9 TEMPORARY PROJECT PARKING

2.9.1 If available, parking within the Project site shall be at the Contractor's discretion, however, at least two (2) marked dedicated parking spaces shall be provided for the Owner's Designated Representative and Construction Inspector at the Project site owner's trailer.

2.9.2 The Owner will not provide Project parking.

2.9.2.1 The Contractor shall acquire any necessary parking permits from the campus for a responsible number of vehicles.

2.10 WELDING REQUIREMENT

2.10.1 For renovation to existing facilities and due to potential electrical surges cause by electrical welding machines, the use of all electrical welding machines is banned from use on the UTHSC campus. All welding machines are to be run with the use of an external generator.

2.11 FLUORESCENT OR MERCURY CONTAINING LAMPS AND BALLASTS

2.11.1 The general contractor is responsible for the proper recycling, through a licensed universal waste handler, for all fluorescent and/or mercury containing lamps and ballasts. Documentation of this recycling shall be submitted to the Owner's ODR/PM.

2.12 BADGE REQUIREMENTS

2.12.1 Contractors must obtain and wear UTHSC badges at all times. A consolidated list of ID badges will be requested through the Owner's ODR/PM who will submit the request to the school or building management for approval. The badge request form will be emailed directly to the parking



The University of Texas
Health Science Center at Houston

office. The contractor will be notified. All campus badges are issued at the parking offices located on the 1st floor main lobby of the University Center Tower, 7000 Fannin Street, Houston, Texas 77030.

- 2.12.2 ID badge access is normally restricted to construction project managers, supervisors and design teams for specific locations that allow free access to the job site. Perimeter access to the building should only be required if work is scheduled after hours or a door that is normally locked must be used.
- 2.12.3 At completion of the project, the ODR/PM will collect all ID badges and insure card reader access is de-activated. If no further work is anticipated the badges will be returned to the parking office by contractor.

PART 3 – EXECUTION

3.1 PROJECT PARTNERING

- 3.1.1 The Owner desires to create a cohesive team for this project, to include all primary parties. The Contractor and its primary Subcontractors shall join the Owner and the rest of the Project Team in project "Partnering" as a means of achieving success. The Partnering process is voluntary and the Owner and Contractor shall equally share all costs with no impact to the Construction Contract price. The results of the workshop are not legally binding, but do represent a commitment by the parties to work together cooperatively toward common goals.

3.2 CONTRACTOR SITE ACCESS AND LIMITS OF CONSTRUCTION

- 3.2.1 Prior to **any** site activity on CSP projects, during Design Development phase on CM/DB projects, and prior to execution of the first GMP, the Contractor shall submit a draft Site Utilization Plan (1" = 30'-0" scale, or larger) showing proposed location of temporary fencing, lay down area, temporary trailers, stabilized construction entrance(s), cranes, signage, parking, temporary utilities, field offices, size and arrangement of spaces, site control points, and utility tie-in locations, dumpster, sidewalk and/or parking space closures, and truck routes in/out of site for Owner review and approval. The Plan must clearly show location and dimension of gates indicating proposed entry circulation and egress sufficient for fire and other emergency vehicles. Give adequate consideration for safe and accessible pathway at perimeter of fencing, and provide signage indicating "Detour," "Dead End," or other messages as appropriate. On CMR/DB projects, the approved site utilization plan will be included in the documents that are the basis for the GMP.
- 3.2.2 All project personnel shall confine and limit their work and use of the Project site to those areas within the defined limits of construction. All public and university rules, laws, and requirements shall be obeyed and enforced by the Contractor. No tools, construction vehicles, or construction material shall be permitted beyond the Project site limits of construction.
- 3.2.3 All campus roads, drives, and fire lanes as well as all sidewalks and pedestrian routes, other than those specifically indicated to be in the Contractor's area of control, must be kept open at all times. The Contractor shall make advance preparations for, and obtain security clearance for, all significant material deliveries and truck traffic, cranes, concrete trucks, etc., through the campus to the project site.

3.3 ON-GOING CAMPUS OPERATIONS

- 3.3.1 The Project is surrounded by and/or adjacent to continuously functioning campus facilities, including academic and research efforts. The Contractor shall make every effort to avoid disruptions to ongoing campus activities and to maintain a safe environment for students, faculty, and staff in the areas adjacent to the project.



The University of Texas
Health Science Center at Houston

- 3.3.2 Campus utilities must not be interrupted except when scheduled and approved in advance by the Owner with appropriate campus technical staff.
- 3.3.3 Any necessary disruption of campus utilities must be scheduled at least five work days in advance through established procedures with campus technical staff. The Contractor shall not activate or de-activate any campus system, or component of any such system, without written direction from the Owner.
- 3.3.4 Equipment locations and timing or sequence of work operations shall be coordinated so as to not conflict with the Owner's continuing use of adjacent buildings and/or create any interference with scheduled meetings or events.
- 3.3.5 The use of the campus' sanitary facilities by the Contractor, or any of the construction workers, is prohibited.
- 3.3.6 Preventable False Fire Alarms that occur during the execution of the work may be subject at the discretion of the Owner to a service charge of \$1,500 per occurrence to be deducted from the CM/R's or D/B's construction phase fee. For CSP projects, this charge will be deducted from the Contractor's contract amount. A Root Cause Analysis (RCA) shall be prepared and used to determine the cause of the alarm and the service charge will be assessed when the findings indicate the alarm was preventable and directly attributable to actions or inaction of the CM/R/Contractor or the subcontract workforce under their direction.

3.4 CONTRACTOR'S RESPONSIBILITY OF THE PROJECT WORKFORCE

- 3.4.1 The Contractor is responsible for the actions of the entire Project workforce, including subcontractors' and suppliers' employees, whenever they are on the campus. Responsibilities may include identification badges for workers, busing of workers from remote parking lot(s), written and verbal reminders to workforce of appropriate behavior and avoidance of campus facilities. Established access and egress routes for vehicular and pedestrian traffic are required, as a minimum, in order to maintain control of the work force.
 - 3.4.1.1 Failure to obtain parking permits, or traffic violations while on campus may lead to cancellation of any Owner provided parking.
 - 3.4.1.2 The Contractor shall demonstrate the plan for controlling the workforce at all times, while on campus. Unacceptable behavior on the part of a worker anywhere on campus, including parking lots, the Project site, and the accessing route(s) through the site through the campus shall be the responsibility of the Contractor.
 - 3.4.1.2.1 Harassment of any person, whether student, faculty, staff, or visitor to the campus, is strictly forbidden. Harassment includes any action such as jeering, whistling, calling-out, staring, snickering, making rude or questionable comments, or similar behavior. Identifiable offending worker(s) shall be permanently removed from the Project.

3.5 PROJECT SECURITY

- 3.5.1 The Contractor is responsible for security of the Project, including site access and exiting. Campus police will not provide security for the Contractor's (or subcontractor's) areas or personnel.
 - 3.5.1.1 The Contractor may employ unarmed security personnel for the Project.
 - 3.5.1.2 The Contractor shall provide a full-time site access monitoring system for the duration of the project



The University of Texas
Health Science Center at Houston

- 3.5.1.3 Canine and other forms of animal security and enforcement are prohibited on the Project site.
- 3.5.1.4 The Owner may reduce or withhold payment to the Contractor, if deemed necessary, until adequate Project security is in place.

3.6 PROTECTION OF WORK

3.6.1 The Contractor and every Subcontractor shall properly and effectively protect all materials and equipment furnished during and after installation. Building materials, contractor's equipment, etc., may be stored on the premises, but the placing of it shall be within the construction fence. When any room in the building is used as a shop, storeroom, etc., the Contractor shall be held responsible for any repairs, patching, and cleaning arising from such use. The Contractor shall protect and be responsible for any damage to its work or material, from the date of the agreement until the final payment is made, and shall make good without cost to the Owner, any damage or loss that may occur during this period. All material affected by weather shall be covered and protected to keep free from damage while being transported to the site and while stored on the site.

3.6.1.1 During the execution of the Work, open ends of all piping, conduit, ductwork, and all openings in equipment shall be capped and sealed prior to completion of final connections, so as to prevent the entrance of foreign matter.

3.6.1.2 All heating, ventilating, plumbing, and electrical equipment shall be protected during the execution of the Work.

3.6.1.3 All plumbing fixtures shall be protected and covered so that no one can use them. All drains shall be covered until placed in service to prevent the entrance of foreign matter.

3.6.1.4 Trees and shrubs, within the Project site assigned to be saved and maintained, shall be protected by the Contractor with strong open slat fences at least six (6) feet high, completely surrounding the perimeter of the drip line, maintained in sound condition until permission is given for removal. The Contractor shall not remove, cut, or trim any trees or shrubs without the Owner's written approval, unless specifically identified to be removed on the Construction Documents.

3.7 PROJECT SURVEYING

3.7.1 The Contractor shall employ an experienced and competent licensed Professional Surveyor to establish at least three separate permanent benchmarks and shall maintain easy access during the progress of the Work, in order to determine and verify the lines and grades. As the Work progresses, the Contractor shall establish additional and easily accessible benchmarks at each level referenced to first floor finish floor line.

3.7.1.1 Level or Transit: The Contractor shall maintain an accurate level or transit at the site at all times. This instrument shall be used to verify lines, grades, etc., and shall be available at all times for use by the Architect/Engineer and the Owner. A level shall be used to layout all work and shall be used by operators skilled in its use.

3.7.1.2 The Contractor shall erect and maintain substantial and braced batter boards at all corners of structures, set their location to provide proper working clearance and verify that they are level and at the proper grade.

3.7.1.3 As the Work progresses, the Contractor shall lay out partitions on the floor in exact locations as a guide to all contractors and trades.



The University of Texas
Health Science Center at Houston

- 3.7.1.4 Before ordering any materials or doing any work, the Contractor shall verify and be responsible for the correctness of all measurements. No extra charge or compensation shall be allowed on account of difference between actual dimensions and the measurements indicated on the Drawings. Any differences, which may be found, shall be submitted to the Architect/Engineer for consideration before proceeding with the Work.

3.8 TEMPORARY SHORING

- 3.8.1 All temporary shoring required for the installation of work shall be included in this Contract and the Contractor shall assume all responsibility for this work and make good any damage caused by improper supports or failure of shoring in any respect. Any provisions that are installed to assure the stability of adjacent structures, trees, roadways, or infrastructure, shall be in accordance with engineered plans (provided by the Contractor).

3.9 CUTTING AND PATCHING OF SLEEVES

- 3.9.1 The Contractor shall consult with the Project Architect/Engineer prior to the commencement of any cutting and/or patching of sleeves, holes, or openings in the execution of the work.

- 3.9.1.1 Excessive cutting of the structure that is not shown in the contract documents shall not be permitted, nor shall any piers or other structural members be cut without the written approval of the Project Architect/Engineer. After such work has been installed, the Contractor shall carefully fit around, close up, repair, patch, and point-up as directed by the Project Architect/Engineer.

- 3.9.1.2 All cutting and patching of sleeves shall be done carefully, with proper tools by qualified workers, at no additional cost to the Owner. The Contractor or Subcontractor shall build into the work, as indicated on the plans and/or specifications, any and all items furnished by others. Cutting and repairing of work in place, as a result of negligence by the Contractor, shall be completed at no cost to the Owner.

- 3.9.1.3 The work performed within each section of the Specifications, unless otherwise indicated in the plans and/or specifications, includes all cutting, patching, and digging for work in that trade section required for proper accommodations of work of other trades. Execute such work with competent workers skilled in trade required for restoration.

- 3.9.1.4 The Contractor shall provide sleeves for all service lines, including piping, ductwork, and conduit covered in their scope of work, which may pass through walls, roof, or floors.

3.10 HAZARDOUS MATERIAL ABATEMENT

- 3.10.1 UTHSC is committed to managing hazardous materials abatement projects in a manner that is safe for all building occupants and Contractor personnel, and in a manner that is compliant with State of Texas regulations concerning asbestos, lead, or mold contaminated materials.

- 3.10.2 Should the Contractor discover unforeseen hazardous materials (e.g., asbestos, lead, mold), the Contractor shall stop work, properly seal off the affected area, and immediately inform the ODR and the campus' Environmental Health & Safety office. The Owner will make provisions to test for and confirm the presence of hazardous materials, and if found, arrange to properly abate the hazardous materials using a licensed abatement subcontractor. The Contractor shall not resume the non-hazardous material-related work in the affected area until the hazardous material has been removed by a licensed abatement subcontractor, and the licensed hazardous materials consultant confirms that the abatement is complete. If lab tests do not indicate the presence of hazardous materials, the Contractor may resume normal activities only after confirmation has been provided by the Owner.



The University of Texas
Health Science Center at Houston

- 3.10.3 The Owner shall ensure that Texas Department of State Health Services licensed individuals, consultants, or companies are used for any required hazardous materials work including inspection, abatement plans/specifications, abatement, project management, and third-party monitoring.

3.11 CERTIFICATION OF NO ASBESTOS/LEAD CONTAINING MATERIALS OR WORK

- 3.11.1 The Contractor shall provide a certification statement, included with each materials submittal, stating that no asbestos or lead containing materials or work is included within the scope of the proposed submittal.
- 3.11.2 The Contractor shall provide at Substantial Completion, a notarized affidavit to the Owner and the Architect stating that no asbestos or lead containing materials or work was provided, installed, furnished, or added to the Project.
- 3.11.3 The Contractor shall take whatever measures necessary to ensure that all employees, suppliers, fabricators, material handlers, subcontractors, or their assigns, comply with this requirement.
- 3.11.4 All materials used on this Project shall be certified as non-Asbestos Containing Building Materials (ACBM). The Contractor shall ensure compliance with the following acts from all Subcontractors:
- 3.11.5 Asbestos Hazard Emergency Response Act (AHERA—40 CFR 763-99 (7))
- 3.11.6 National Emission Standards for Hazardous Air Pollutants (NESHAP—EPA 40 CFR 61, National Emission Standard for Asbestos)
- 3.11.7 Texas Asbestos Health Protection Rules (TAHRP—Tex. Admin. Code Title 25, Part 1, Ch. 295C, Asbestos Health Protection)
- 3.11.8 The Contractor shall provide a notarized statement from all subcontractors that no ACBM or lead has been used, provided, installed, furnished, added to, or left on the Project.
- 3.11.9 The Contractor shall provide, in hard copy and electronic form, all necessary safety data sheets (SDS) of all products used in the construction of the Project to the Texas Department of State Health Services licensed inspector. The contractor shall provide a person appropriately licensed in accordance with the provisions of the Texas Administration Code, Title 25, Part 1, Ch. 295C, and compile the information from the safety data sheets of all products used in the construction or renovation, and finding no asbestos or lead in any of those products, prepare a signed written certification that he has reviewed the SDSs for all products used in the construction and that none of those products contain ACBM or lead and; therefore, the building materials do not contain asbestos.
- 3.11.10 At Final Completion the Contractor shall provide a notarized certification statement per TAC Title 25 Part 1, Ch. 295.34, par. c.1 that no ACBM or lead was used during construction of the Project.
- 3.11.11 The Contractor shall retain an asbestos consultant licensed by the Texas Department of State Health Services, Texas-registered architect, or Texas-licensed engineer to evaluate SDS of permanently installed building materials and provide a signed, written certification that the Work does not contain asbestos.
- 3.11.12 The certification letter should be substantially the same form as the following for renovation and new construction:



The University of Texas
Health Science Center at Houston

- 3.11.13 For renovation: I, [Name], Asbestos Consultant, Texas-registered architect or Texas-licensed professional engineer) (license #****TX), was involved in the design and construction of the new renovation of the [Project]. I have reviewed all of the Safety Data Sheets (SDSs) of all the products permanently installed in the current renovation and none of the products indicate that they include Asbestos-Containing Materials (ACBM) and therefore in my professional opinion, the building materials used in this renovation do not contain asbestos. This certification, together with copies of the SDSs, may be used as an asbestos survey as described in the Texas Asbestos Health Protection Rules §295.34(c)(1).
- 3.11.14 For new construction: I, [Name], Asbestos Consultant, Texas-registered architect or Texas-licensed professional engineer) (license #****TX), was involved in the design and new construction of the [Project]. I have reviewed the Safety Data Sheets (SDSs) of all the products permanently installed in the construction project and none of the products included in the construction indicate that they include Asbestos-Containing Materials (ACBM) and therefore in my professional opinion all parts of the building do not contain asbestos. This certification, together with copies of the SDSs, may be used as an asbestos survey as described in the Texas Asbestos Health Protection Rules §295.34(c)(1).

PART 4 – SUBSTANTIAL COMPLETION

4.1 ELECTRONIC OPERATIONS AND MAINTENANCE MANUALS AND RECORD DOCUMENTS

- 4.1.1 Prior to Requesting Substantial Completion, and as a prerequisite thereto, and prior to submitting Application for Payment including release of any sums held as retainage, and in lieu of the following requirement in UGC 6.2.5 to:

4.1.1.1 *“...provide one (1) reproducible copy and one (1) electronic media copy in a format acceptable to the ODR of all Record Documents, unless otherwise required by the Owner’s Special Conditions”. In addition, original drawings in the most recent version of AutoCAD will be provided.*

4.1.1.2 Contractor shall provide instead, in electronic format as specified herein, all Operating and Maintenance manuals, approved submittals, shop drawings, warranties, certificates, test reports, record documents, commissioning documentation and other items as required by the contract. This requirement is in addition to hardcopies of these documents and all other submittals required elsewhere in the contract, except as specifically stipulated herein.

4.1.2 All small format (11” x 17”) or smaller photographs, cut sheets, sketches, instructions, diagrams & graphical literature shall be scanned at a resolution of at least 300 DPI to produce sufficient quality to allow zoom features and readable prints. Color charts or other documents where color is required to convey full information shall be scanned in color. Color line drawings shall be scanned at 200 DPI to avoid excessive file size.

4.1.3 All documents shall be scanned into a single file in current version of Adobe PDF format with expandable indexed file structure organized according to current CSI format and shall conform to AIA standards, bookmarked to at least Division and Section level and searchable by keyword. Verify that all pages on every document have been scanned. Review each page to ensure scan captures original detail. If images appear too dark or too light, or smudged, rescan to ensure proper image quality & legibility.

4.1.4 Proper labeling must appear on the disk and jewel case to include the Owner's Name (Institution), Project No & Title, Contents of CD / DVD (O&M Record Documents DIV 1- 33),



The University of Texas

Health Science Center at Houston

the Sequence Number of the disk if part of a multi-disk set (i.e. DVD 1 of 3) and the Archive Date. CD/DVD must be inkjet printable not using adhesive labels which can delaminate and gum up reader mechanism.

- 4.1.5 Prior to final submission, (2) two preliminary sets shall be provided for review and approval: One set for Project Architect/Engineer (AE) to review for completeness and accuracy, and one for Facilities Management (FM) to review for conformance to format and file structure as stated herein. Upon acceptance by Project AE and FM, provide **(7) seven** sets of CD-ROM's or DVD's.
- 4.1.6 This requirement in no way modifies or alters other requirements of UGC 6.2.1 through 6.2.4 or in any way diminishes contractor's responsibility therein defined regarding the requirements prior to requesting Substantial Completion.

END OF OWNER'S SPECIAL CONDITIONS



(to Owner's Special Conditions)

PREVAILING WAGE RATE DETERMINATION

The University of Texas System is the contracting agency for this construction project. The following statute requires the contracting agency to specify the generally minimum rates of wages in contracts that are bid.

Government Code 2258
"Construction of Public Works in State and
Municipal or Political Subdivisions; Prevailing
Wage Rates to be maintained"
and
The Uniform General Conditions
for University of Texas System Building Construction Contracts

Pursuant to the requirements of this statute, we have determined that the following rates of wages are paid to various classifications of workers in the locality of this project.

Total hourly compensations to each worker must equal or exceed the minimum wage rates stated in the following attachment. Contributions by a worker toward health, pension, vacation, and the like are part of the worker's pay; contributions by the employer are not. Any dollar amounts shown in columns for health, pension, and vacation may be paid either in cash or in kind. Workers in classifications where rates are not identified shall be paid not less than the general minimum rate of "laborer" for the various classifications of work therein listed.

All hours of work over 40 hours per week are overtime and will be compensated at the rate of 1 and ½ times the regular wage.

Trainees/helpers, where not otherwise specified above, may be compensated at a rate determined mutually by the worker and employer, commensurate with the experience and skill of the worker but a rate not less than 60% of the journeyman's wage or less than the Laborers (General) rate. At no time shall a journeyman supervise more than two of apprentices, trainees or helpers. All apprentices/trainees/helpers shall be under the direct supervision of a journeyman working as a crew.

The University of Texas System

Date: June 30, 2015
Construction Type: Building
Area: Houston-Galveston

Building Construction Trade Classification	Prevailing Wage Rate (1)
Carpenter	\$15.00
Concrete Finisher	\$15.75
Drywall/Ceiling Installer	\$14.50
Electrician	\$17.00
Elevator Mechanic	\$30.04
Fire Proofing Installer	\$15.00
Flooring Installer	\$20.00
Glazier	\$16.91
Heavy Equipment Operator	\$16.00
Ironworker	\$17.00
Laborer	\$10.50
Light Equip Operator/Driver	\$15.00
Mason/Bricklayer	\$18.00
Painter	\$14.25
Pipefitter	\$17.72
Piping/Ductwork Insulator	\$15.00
Plumber	\$19.99
Rofer	\$14.00
Sheetmetal Worker	\$18.00
Sprinkler Fitter	\$19.20
Tile Setter	\$15.00
Waterproofers	\$15.00

- (1) Wages shown are for entry level, minimum wages for each classification and do not include fringe benefits**
- (2) Unlisted classifications needed for work not included within the scope of the classifications listed may not be added after award. The job classifications are not inclusive of all possible trades on the construction project.**
- (3) It is the responsibility of the contractor to classify the worker in accordance with the published classifications, and demonstrate that workers are paid commensurate with determined rates.**



The University of Texas
Health Science Center at Houston

ATTACHMENT "B"

(to Owner's Special Conditions)

PROJECT SIGN

SEAL (EITHER UT SYSTEM OR INSTITUTIONAL SEAL)

 <p>The University of Texas Health Science Center at Houston</p> <p>THE UNIVERSITY OF TEXAS HEALTH SCIENCE CENTER AT</p>	NAME OF PROJECT	PICTURE OF PROJECT
	NAME OF INSTITUTION	
FACILITIES, PLANNING AND ENGINEERING	ARCHITECT ENGINEER - (FIRM'S NAME)	
	GENERAL CONTRACTOR - (FIRM'S NAME)	

*ADJUST LETTER SIZE AS REQUIRED FOR LENGTH OF NAME. STYLE OF LETTERING TO BE ARIAL BOLD.

SUBMIT A ONE-QUARTER SCALE SHOP DRAWING OF THE SIGN COMPLETE WITH ALL LETTERING TO THE OWNER FOR APPROVAL BEFORE CONSTRUCTION. THE SIGN SHALL BE CONSTRUCTED OF 3/4 INCH THICK A-C GRADE EXTERIOR PLYWOOD. THE SIGN SHALL RECEIVE TWO COATS OF AN APPROVED WHITE SEMIGLOSS EXTERIOR ENAMEL ON ALL SURFACES BEFORE LETTERING. THE OWNER WILL DESIGNATE THE COLORS FOR THE LETTERING ON THE SHOP DRAWING.

SCHEDULE

LINE	DESCRIPTION	LETTER HEIGHT *	STROKE *
1	NAME OF PROJECT	2-1/4"	1/2"
2	NAME OF INSTITUTION	2-3/4"	1/2"
3	THE UNIVERSITY OF TEXAS SYSTEM	1-1/4"	1/4"
4	OFFICE OF	2" & 1-1/2"	3/8" & 1/4"
5	FACILITIES	2" & 1-1/2"	3/8" & 1/4"
6	PLANNING AND	2" & 1-1/2"	3/8" & 1/4"
7	CONSTRUCTION	2" & 1-1/2"	3/8" & 1/4"
8	SEAL (APPROX. 8" DIAMETER)		
9	ARCHITECT ENGINEER - (FIRM'S NAME)	1-1/2"	1/4"
10	GENERAL CONTRACTOR - (FIRM'S NAME)	1-1/2"	1/4"

FRONT ELEVATION **SIDE ELEVATION**
PROJECT SIGN DETAILS - NOT TO SCALE

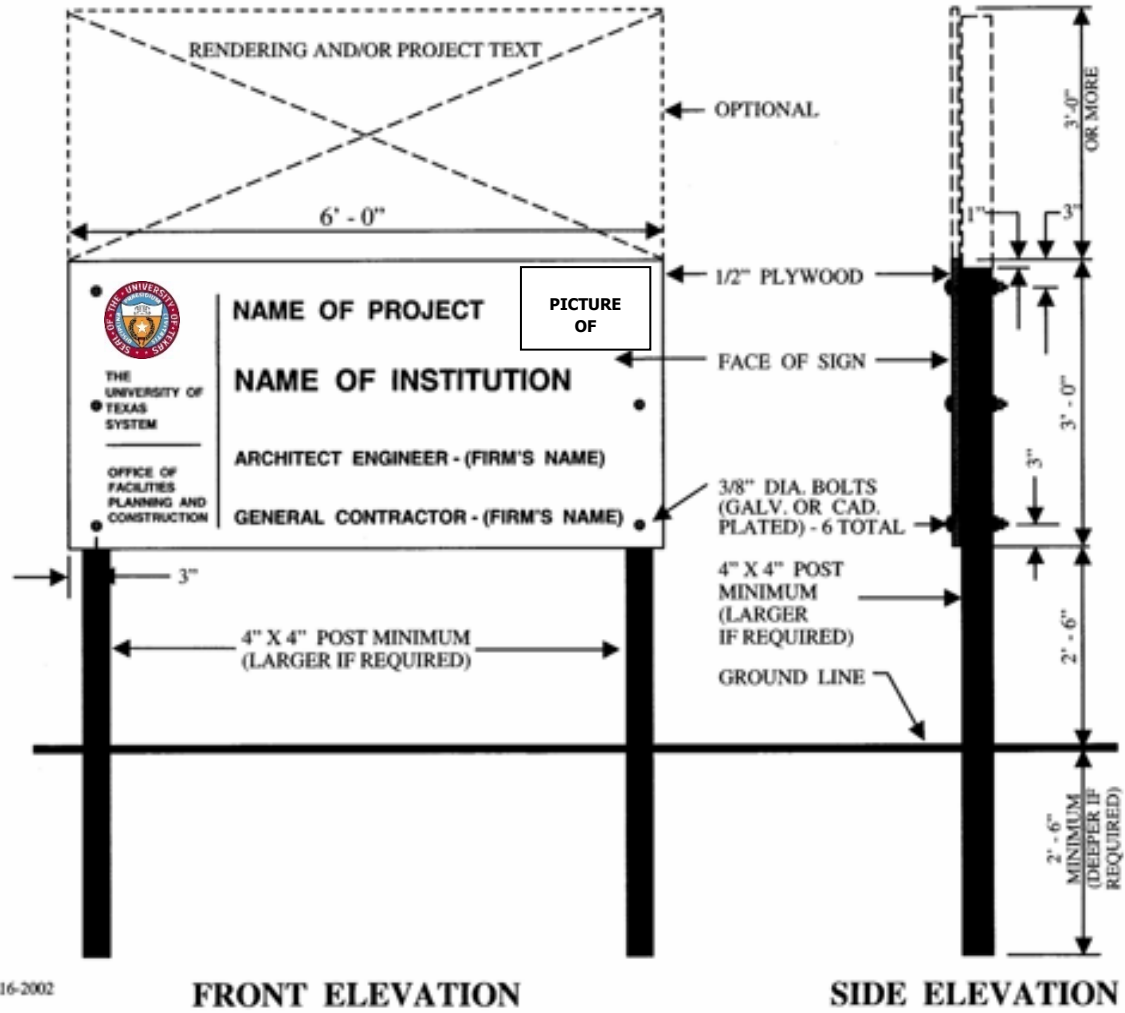

12-16-2002

PROJECT SIGN DETAILS - NOT TO SCALE



The University of Texas
Health Science Center at Houston
ATTACHMENT "C"

(to Owner's Special Conditions)

WEATHER DAYS

C1.1 In addition to the project scheduling requirements outlined in the Uniform General Conditions for UT System Construction Contract (UGC), the minimum Total Float required per specification section 01 32 00 - PROJECT PLANNING AND SCHEDULING, and those stipulated in the Owner-Contractor Agreement, the Contractor shall plan for at least the following number of Weather Days for the corresponding institution in the construction schedule.

Weather Days (Calendar Days)												
Institution	Jan	Feb	Mar	Apr	May	Jun	Jul	Aug	Sep	Oct	Nov	Dec
UT Arlington, UT Dallas, and UT Southwestern Medical Center Dallas	6	4	4	3	4	4	1	1	2	3	2	4
UT Austin	4	4	4	4	4	4	4	3	4	5	4	4
UT San Antonio and UT Health Science Center San Antonio	4	4	4	4	4	3	4	2	4	4	4	4
UT Tyler and UT Health Science Center Tyler	6	4	5	4	5	5	3	3	3	5	4	5
UT Rio Grande Valley	2	2	2	2	3	3	3	3	5	3	2	3
UT Medical Branch Galveston	4	4	4	3	3	4	6	5	5	4	4	5
UT Health Science Center Houston and UT M.D. Anderson Cancer Center	3	3	3	2	2	3	5	4	6	6	6	5
UT El Paso	1	1	1	1	1	2	4	5	3	1	1	3
UT Permian Basin	3	3	2	2	2	3	4	3	4	2	2	3

Note: see F:\users\UTHSC\PMSS\Project Improvements\Improvement stuff\Owners Spec Conditions Updates\Weather Days\Climatological Data & Update Instructions.xlsx for methodology on derivation of anticipated weather days.

C1.2 A Weather Day, as defined in UGC 9.6.2.1, is further defined as a day with 0.25 inches of rainfall or more, and/or has an average temperature at or below 32 degrees, and/or has a sustained wind speed (average of observed values over a two minute period) above 25 miles per hour (21.7 knots) as recorded at the project jobsite.



The University of Texas
Health Science Center at Houston

- C1.3 Weather Days shall be planned for by the Contractor in the preparation, development, and monitoring of the construction baseline schedule and status of subsequent updates.
 - C1.3.1 Weather Days shall be recorded as full calendar days.
 - C1.3.2 Weather Days shall not be included as a construction schedule activity nor as additional float (i.e., days are included as part of the activity's original duration).
- C1.4 The Contractor shall submit written notification to the Owner's Designated Representative (ODR) of an actual Weather Day within two (2) business days of the event. The written notification must contain the same amount of information as that shown on the attached Exhibit 1 to Attachment "C" - Monthly Documentation of Adverse Weather form. An editable version of this form is available (not mandatory) for use from the ODR.
- C1.5 The Contractor may be granted a contract time extension due to weather only when 1) actual weather days exceed the number of weather days for the month shown on the table above, 2) the available project Total Float is zero or less, and 3) the Weather Day causes an actual delay to the Substantial Completion date of the project by impacting one or more planned activities on the longest path of the approved updated Contractor's construction schedule.
 - C1.5.1 Time extensions for Weather Days are non-compensatory per Articles 9 and 11 of the UGC for delay of, and extension of time requirements.



The University of Texas
Health Science Center at Houston

EXHIBIT 1 to ATTACHMENT "C"

(to Owner's Special Conditions)

University of Texas Health Science Center at Houston
Monthly Weather Report

Month of: _____
Date Submitted: _____

Project No. and Name: _____
Contractor: _____

If applicable, attach document for justification of time extension, or use of schedule float, by demonstrating the delay or critical path activities.

Date [mm/dd/yy]	Day [Su, M, T, W, Th, F, S]	Weather Event [in. of rain, wind speed, etc.]	Time Frame [9 am - 2 pm]	Critical Path			
				Activities (Critical path and non-critical path)	Y/N	ODR Initials	Comments

NO. Days in Month: _____

Contractor's Signature: _____

Less Expected Days Per OSC "Exh C": _____

Printed Name: _____

Days Requested: _____



The University of Texas
Health Science Center at Houston
REVISION LOG

The following is provided for convenience to the Owner, Architect/Engineer and Contractor to track changes between annual document issuances and is not to be considered by any party to be contractual or 100% complete.

Date	Paragraph Revised	Initials

SECTION 00 73 16 - PROJECT INSURANCE REQUIREMENTS

PART 1 - GENERAL

1.1. DEFINITIONS

- 1.1.1. The term “OCIP”, as used throughout the Contract documents, shall refer to the Owner Controlled Insurance Program.
- 1.1.2. The term “OCIP Administrator”, as used throughout the Contract documents, shall refer to those employees of the firm that acts as the Owner’s Insurance broker whose duties include, but are not limited to, confirming Contractor and Subcontractor enrollments, tracking monthly payroll reports, ordering final payroll audits, and reporting program costs to the Owner.
- 1.1.3. The term “OCIP Loss Control Representative”, as used throughout the Contract documents, shall refer to those employees and representatives of the firm that acts as the Owner’s Insurance broker who conduct Project site safety services, track insurance claims, and issue reports concerning Contractor management of safety and insurance claims.
- 1.1.4. The term “MWrap”, as used throughout the Contract documents, shall refer to the OCIP Administrator’s online portal which shall be utilized by Contractor and all enrolled Subcontractors to submit documentation relative to the OCIP.

1.2. PURPOSE

- 1.2.1. The purpose is to have one (1) major insurance program in place to address those risks associated with Workers' Compensation and Employer's Liability, and General Liability which will exist on the Owner's property during construction. The Owner expects the majority of employers performing construction work under this Contract to enroll in the OCIP.
- 1.2.2. The Owner shall provide, at its own expense, specific insurance policies and coverage for the Contractor and for all enrolled Subcontractors on the Project, as described in Article 2.1 and 2.2 of this Section.
- 1.2.3. The Contractor and all enrolled Subcontractors shall provide all other insurance coverages, including those described in Articles 2.3 in this Section and as necessary or required to address all other risks for the Project.
- 1.2.4. **The Contractor and all enrolled Subcontractors shall disregard those Articles of the Uniform General Conditions for University of Texas Building Construction Contracts (UGC) which are in conflict with this Section and shall recognize and agree to the requirements described in this Section.**
- 1.2.5. **The Subcontractors and all other parties to the Contract that are not enrolled shall furnish proof of insurance in accord with the UGC.**

1.3. RELATED DOCUMENTS

1.3.1. In addition to specific references indicated herein, the Contractor's attention is directed, but not limited, to the following Sections and Documents, which include additional administrative requirements.

1.3.1.1. Current Edition of the Uniform General Conditions for University of Texas Building Construction Contracts (UGC).

1.3.1.2. Owner's Special Conditions and 01 35 23 Project Safety Requirements

PART 2 – PRODUCTS

2.1 INSURANCE COVERAGE FURNISHED BY OWNER (OCIP): The following insurance shall be furnished to the Contractor and all enrolled Subcontractors in separately issued coverage. A copy of the Project Insurance Manual is provided as Attachment A.

2.1.1 Workers' Compensation and Employer's Liability

2.1.1.1 Carrier and contact information as provided in the Project Insurance Manual.

2.1.1.2 Policies will be issued on an annual basis until project substantial completion.

2.1.1.3 Coverage A - Statutory Benefits: Liability imposed by the Workers' Compensation and/or Occupational Disease statute of the State of Texas and any other State or governmental authority having jurisdiction over or related to the work performed on the Project.

2.1.1.4 Coverage B - Employer's Liability Limits:

2.1.1.4.1 \$1,000,000.00 bodily injury per accident/employee;

2.1.1.4.2 \$1,000,000.00 bodily injury per disease/employee;

2.1.1.4.3 \$1,000,000.00 policy limit by disease.

2.1.1.5 Extensions of Coverage

2.1.1.5.1 Other States Endorsement(s)

2.1.1.5.2 Voluntary Compensation, if exposure exists may be added

2.1.1.5.3 United States Longshoreman's & Harborworker's Act, may be added if needed

2.1.1.5.4 Ninety (90) day Notice of Cancellation from the Insurance Provider, except 10 days for non-payment of premium

2.1.1.5.5 Amendment of Notice of Occurrence

2.1.2 Commercial General Liability (Primary and Excess)

2.1.2.1 Carrier and contact information as provided in the Project Insurance Manual.

2.1.2.2 Certificates of Insurance will be issued naming each Contractor as a named insured upon enrollment.

2.1.2.3 Limits:

2.1.2.3.1 \$2,000,000.00 Each Occurrence/all insured

2.1.2.3.2 \$2,000,000.00 Personal Injury and Advertising Injury limit

2.1.2.3.3 \$5,000,000.00 Completed Operations aggregate/all insured

2.1.2.3.4 \$5,000,000.00 General Aggregate/all insured (Annual Aggregate Per Project)

2.1.2.3.5 \$10,000.00 Medical Expense Limit

2.1.2.3.6 \$250,000.00 Fire Legal Liability

2.1.2.4 Policy Form:

2.1.2.4.1 Insurance Service Office "Occurrence" form – CG 00 01 (12/07)

2.1.2.5 Extensions of Coverage:

2.1.2.5.1 Incidental Medical Malpractice Liability

2.1.2.5.2 Completed Operations Liability coverage for a period of ten (10) years after substantial completion notification by the Owner.

2.1.2.5.3 Waiver of Subrogation Endorsement, if required by written contract

2.1.2.5.4 Ninety (90) day Notice of Cancellation from the Insurance Provider, except 10 days for non-payment of premium

2.1.2.5.5 Engineers, Architects or Surveyors Professional Liability Exclusions

2.1.2.5.6 Extended Ongoing Operations coverage for repair work for a period of two (2) years after Substantial Completion.

2.1.2.6 Excess Liability Coverage:

2.1.2.6.1 As following form over Employer's Liability and Commercial General Liability, \$100,000,000.00 of excess insurance has been obtained by the

Owner for the benefit of the Owner, Contractor and all enrolled Subcontractors of every tier.

2.1.2.6.2 Carrier and contact information as provided in the Project Insurance Manual

2.1.3 Deductible:

2.1.3.1 Insurance policy deductibles under the OCIP program are paid by the Owner

2.1.3.2 Issue of Certificates:

2.1.3.2.1 The OCIP Administrator and/or Insurance Carriers will issue separate Certificates of Insurance for Workers' Compensation, Comprehensive General Liability and Excess Liability to the Contractor and each enrolled Subcontractor. Copies of holder policies will be issued following receipt of written request from the OCIP Certificate holders to the OCIP Administrator and copied to the ODR.

2.2 INSURANCE COVERAGE FURNISHED BY OWNER (BUILDER'S RISK) - COVERAGE AND DEDUCTIBLE DESCRIPTION:

2.2.1 The Owner intends to provide builder's risk insurance for this project. Refer to the Agreement for additional information (Art. 17 in the CM & DB Agreements and Art. 11 in the CSP Agreement).

2.2.2 The Contractor and all subcontractors shall disregard Article 5.2.2.1.5 through 5.2.2.1.5.10 and 10.5.2 of the Uniform General Conditions for UT System Construction Projects (UGC) and shall recognize and agree to the requirements described in this Section.

2.2.3 Owner will purchase and maintain in force builder's risk insurance on the Work. The insurance will apply on a replacement cost basis with no coinsurance provision.

2.2.4 This insurance will name as insureds the Owner, the Contractor, and all subcontractors and sub-subcontractors in the Work but only to the extent of their financial interest in the Work.

2.2.5 Builder's risk insurance will be on an "all risk" or equivalent policy form and will include insurance against fire and extended coverage perils, theft, vandalism, malicious mischief, collapse, earthquake, flood, windstorm, boiler and machinery/mechanical breakdown, testing and startup, and terrorism.

2.2.6 The builder's risk insurance will be specific as to coverage and will be primary to any permanent insurance or self-insurance that may be maintained on the property by Owner.

2.2.7 The builder's risk insurance will include a waiver of subrogation in favor of Owner, the Contractor, and all subcontractors and sub-subcontractors in the work.

- 2.2.8 Upon request, Owner will provide to Contractor a certificate of insurance that provides evidence of builder's risk insurance.
- 2.2.9 In the event of an insured loss caused by the action or inaction of Contractor, any subcontractor or sub-subcontractor, or by anyone directly or indirectly employed by any of them, or by anyone for whose acts any of them may be liable, Contractor will be responsible for, and reimburse to Owner, any applicable deductible under the builder's risk insurance policy, which may be up to \$50,000. Any costs associated with Contractor's responsibility for the applicable deductible will not be considered cost of Work.
- 2.2.10 Any loss insured under Owner's builder's risk insurance will be adjusted by the Owner as fiduciary and made payable to the Owner as fiduciary for the insureds, as their interests may appear. Contractor shall track and submit all claim expenses on a time and materials basis unless previously agreed to in writing by Owner. Any mark-up expenses included as part of the claim expenses will be subject to the percentage maximums specified in the initial agreement. The Contractor shall pay Subcontractors their just shares of insurance proceeds received by the Contractor, and by appropriate agreements, written where legally required for validity, shall require Subcontractors to make payments to their Sub-subcontractors in a similar manner. Contractor will be required to provide a Release of Lien to Owner for any insurance proceeds received by the Contractor.
- 2.2.11 Owner's builder's risk insurance will not cover Contractor's, Subcontractors' and Sub-subcontractors' construction machinery, equipment and tools used in the performance of the work. It will be the Contractor's, Subcontractors' and Sub-subcontractors' responsibility to insure their construction machinery, equipment and tools. Contractors, Subcontractors and Sub-subcontractors shall waive all rights of subrogation and recovery against and in favor of Owner for any loss, claim or expense, including, but not limited to, partial or total damage or theft.
- 2.2.12 Contractor shall assist Owner in obtaining and maintaining builder's risk insurance by providing, in a timely manner, project-related information required by an insurance carrier when requested by the Owner or the Owner's insurance broker.
- 2.2.13 Contractor, in coordination with University project manager, must report every claim within twenty-four (24) hours, or no later than the close of business on the next business day, after discovery of a loss or potential loss in accordance with the Builder's Risk Claims Guide, which will be provided once coverage for the Project is bound. Failure to immediately report a loss or potential loss may result in the issuance of a reservation of rights letter by insurers which could prejudice any potential insurance related recovery. Contractor may be liable for any damages that are not covered by insurance due to late notice of a loss or potential loss.
- 2.3 **INSURANCE POLICIES AND AMOUNTS OF COVERAGE FURNISHED BY CONTRACTOR AND ENROLLED SUBCONTRACTORS:** All Project insurance not identified in Article 2.1 and 2.2 above shall be provided by the Contractor and all enrolled Subcontractors to meet or exceed terms and amounts of coverage as per requirements of the UGC. Liability coverages shall include the following (as applicable to the Work):

- 2.3.1 Business Automobile Liability Owned/Leased
- 2.3.2 Equipment (covering total value of owned/rented equipment)
- 2.3.3 Workers' Compensation/Employers' Liability (for work not covered by the OCIP program)
- 2.3.4 General Liability (**Off Site Only**)
- 2.3.5 Professional Liability Insurance (Errors and Omissions)
 - 2.3.5.1 In the event any Contract specifications require a contractor to provide professional services, such as, but not limited to, architectural, engineering, construction management, surveying, design, etc., a Certificate of Insurance must be provided prior to commencing work evidencing such coverage with a limit of not less than \$1,000,000.00. Any material change in limits, coverage or loss of aggregate limit due to outstanding claims must be reported to the Owner within thirty (30) days of any such event.
- 2.3.6 Aviation Insurance - \$10,000,000.00 (as applicable)
 - 2.3.6.1 In the event any fixed-wing or rotary aircraft are used in connection with this Agreement and/or in the execution of the work, a minimum of \$10,000,000 of Aviation Liability Insurance must be maintained with the following requirements: The Owner must be named as an "additional insured" and a waiver of hull damage must be provided in favor of the Owner.
 - 2.3.6.2 If any aircraft is to be used to perform lifts at the Project site, a "slung cargo" endorsement must be included to cover the full replacement value of any equipment or material being lifted. All such lifts must be coordinated with the Owner for approval prior to lift execution.
- 2.3.7 Environmental and Asbestos Abatement Insurance - \$5,000,000.00 per claim (as applicable)
 - 2.3.7.1 If this Agreement involves environmentally sensitive operations (such as the removal of asbestos, the removal/replacement of underground tanks or operations involving toxic chemicals, heavy metals and/or carcinogenic substances), the Contractor and/or involved Subcontractors shall submit proof of full coverage for such exposures subject requirements and obtain approval of the Owner prior to commencement of such operations. Subcontractors that are directly and actively involved in the performance of work associated with environmentally sensitive operations will be excluded from the OCIP. If Environmental Coverage is written on a Claims Made basis, five years Completed Operations shall be included.

2.3.8 Maritime Insurance - Hull, Protection and Indemnity (including crew) - \$10,000,000.00 (as applicable)

2.3.8.1 In the event any watercraft is used in connection with the Project, the Contractor and/or involved Subcontractor shall submit proof of a "Hull and Protection and Indemnity Policy". The amount of insurance on the Hull shall be sufficient to cover the watercraft, its equipment and all additional equipment aboard during the time it is in use on the Project. Protection and Indemnity shall have limits of liability of no less than \$10,000,000.00 including coverage of the construction activity for which the watercraft is used. Master and Crew coverage shall include General Maritime Liability, Jones Act and Wages, Transportation, Maintenance and Care.

2.3.9 Waiver of Subrogation

2.3.9.1 To meet the requirements of Article 2.3, all policies shall contain a Waiver of Subrogation in favor of the Board of Regents of The University of Texas System, their respective agents, consultants, servants and employees of each and all other indemnities.

2.3.10 Names of Additional Insured

2.3.10.1 To meet the requirements of Article 2.3, for each of the preceding coverages, excepting Workers Compensation, all policies shall endorse the Board of Regents of The University of Texas System, its respective agents, consultants, servants and employees of each and all other indemnities as "Additional Insured".

2.3.11 Waiver of Property Damage and Right of Recovery

2.3.11.1 To meet the requirements of the UGC, all policies shall contain written agreement to waive the Contractor's and each enrolled Subcontractor's right for recovery of physical damage or loss to their respective properties against each other for damages, losses or claims arising out of or in connection with this Project and this Contract. This written waiver shall also extend to the benefit of the Board of Regents of The University of Texas System, its respective agents, consultants, servants and employees. This waiver of the right of recovery for property damage shall be binding upon any property (real or personal), builders risk, automobile, aircraft, watercraft, tools or equipment insurer as respects any subrogation rights that such insurer may possess by virtue of any payments of damage or loss.

2.4 CONTRACTOR ASSURANCE OF SAVINGS

2.4.1 The Contractor and all enrolled Subcontractors shall agree, warrant, and represent that any proposal(s) for Construction services exclude all costs associated with Owner furnished insurance coverage as specified in Article 2.1 and 2.2 of this Section.

- 2.4.2 The Contractor and all enrolled Subcontractors shall agree to be subject to audits for payroll, work hours and insurance costs by the respective insurance companies providing coverage under the OCIP. The purpose of such audits is to validate insurance premiums and compare wages and other OCIP costs. The Contractor and all Subcontractors shall agree to furnish payroll and other information in the forms and formats as requested by the OCIP Administrator in the ROCIP Project Insurance Manual and as required via MWrap. Further, the Contractor and all Subcontractors agree to cooperate fully with any and all audits by supplying the required information in the manner required and as expeditiously as possible. If proprietary information is involved, the Contractor and all enrolled Subcontractors will be allowed to guard the material while it is being reviewed by the Owner or any of its agents.
- 2.4.3 The Contractor and enrolled Subcontractors agree, warrant, and represent that all Changes to the Contract as described in the UGC, shall exclude any cost for the insurance provided by the OCIP.
- 2.5 EXCLUSION FROM OCIP ENROLLMENT: Prior to commencement of any work at the Project site and until completion and acceptance of Work, Subcontractors that are allowed by the Owner to be excluded from enrollment in the OCIP shall maintain, at their sole expense, insurance coverage as per the UGC and Article 2.3 of this Section.
- 2.5.1 Automatic Exclusion
- 2.5.1.1 Temporary workforce agencies (unless approved per Article 3.1.5), consultants, vendors, suppliers, material dealers, and delivery service companies shall not be considered as a Contractor or Subcontractor and therefore shall be automatically excluded from enrollment in the OCIP. The Contractor shall confirm that the companies in these categories produce copies of proof of proper insurance for the risk exposures that each one will create or experience while on the Project.
- 2.5.1.2 Subcontractors performing environmentally sensitive or highly hazardous work will be required to furnish proof of special coverage in adequate amounts for Aviation Insurance, Environmental and Asbestos Abatement Insurance, Maritime Insurance and any other policies of such nature.
- 2.5.1.2.1 Before performing any work, the Subcontractor shall provide to the Contractor and the OCIP Administrator, a Certificate of Insurance that matches the requirements described in the UGC and 2.3 above.
- 2.5.1.3 Excluded Subcontractor(s) shall adhere to all project safety requirements and take all necessary precautions to protect all other persons in the vicinity from the risk exposures that the excluded Subcontractor may create while performing work on the Project.

2.5.2 Discretionary Exclusion

2.5.2.1 The Contractor may issue a written request on behalf of a Subcontractor of any tier for a discretionary exclusion from enrollment in the OCIP. To be considered, the Subcontractor must be bound to a scope of Work that anticipates a total labor value of less than \$5,000.00. A Certificate of Insurance with coverage amounts and language as required by the UGC and 2.3 above shall be furnished to the OCIP Administrator. The OCIP Administrator, in concurrence with the ODR, will review issues such as prior enrollment, scope of work and associated risk. Based on this evaluation, exclusion may or may not be granted.

2.5.3 Excluded Subcontractors

2.5.3.1 Excluded Subcontractors shall submit Certificates of Insurance for Owner acceptance for adequacy of protection and for the satisfactory character of the Insurer prior to performing any work on the Project. Each Certificate must have a thirty (30) day prior written notice of cancellation showing the Board of Regents of The University of Texas System as the Certificate Holder.

2.5.3.2 In the event of failure of the excluded Subcontractor to furnish and maintain said insurance and to furnish satisfactory evidence thereof, the Owner and/or Contractor shall have the right to take out and maintain coverage for all parties on behalf of the excluded Subcontractor who agrees to furnish all necessary information to bind such coverage and to allow deduction for the cost thereof immediately upon presentation of an invoice.

2.6 GOVERNING CONDITIONS

2.6.1 The Owner's payment of premiums for the insurance described in this section shall in no way be interpreted as relieving the Contractor and/or any enrolled Subcontractor of any responsibility of liability under this agreement.

2.6.2 The amount and types of insurance coverage required herein shall not be construed to be a limitation of liability on the part of the Contractor or any of its Subcontractors.

2.7 ELECTIVE INSURANCE FURNISHED BY A CONTRACTOR

2.7.1 The Contractor and any enrolled Subcontractor may elect to maintain a supplementary insurance policy(s) to extend the coverage terms and/ or conditions that are described in this Section. The cost of any policy(s) shall be at the sole expense of the contractor, and shall not be reimbursed by the Owner.

PART 3 – EXECUTION

3.1 OCIP ENROLLMENT PROCESS

- 3.1.1 The Contractor shall provide all subcontractors with the information in this Project Insurance Requirements, not later than the 10th day before the Contractor enters into a contract with the subcontractor. The Contractor shall provide written acknowledgement from each subcontractor to the OCIP Administrator of enrollment and issuance of OCIP “Certificate of Insurance”.
- 3.1.2 The Contractor and all enrolled Subcontractors shall submit all insurance, underwriting, payroll, rating or loss history information as required by the Owner to the OCIP Administrator for enrollment and issuance of OCIP “Certificates of Insurance” via MWrap. The OCIP Administrator shall provide MWrap Contractor Portal Instructions which shall guide Contractor and its Subcontractors in accessing and using MWrap. Online forms, and other requested documentation, shall be completed within ten (10) working days of contract award unless work under the contract is commencing within this ten day period which shall cause the Subcontractor to expedite his enrollment via MWrap. No contractor shall perform any work on the Project until it is recognized as having been enrolled in or excluded from the OCIP by the OCIP Administrator.
- 3.1.3 The Contractor and enrolling Subcontractors shall provide all information necessary to bind coverage under the OCIP. The OCIP Administrator will notify the Contractor and respective Subcontractor when an application has been approved and coverage afforded.
- 3.1.4 OCIP enrollment will not be complete and work shall not commence until the OCIP Administrator has issued the OCIP “Certificates of Insurance” to the applicant.
- 3.1.5 General Contractor(s) and Subcontractor(s) of any tier who perform operations on the Project site and such other persons or entities as Owner may designate as enrolled parties, who perform direct labor at the project site or sites incidental to the Work are considered enrolled parties. **Temporary labor services and leasing companies are to be included as Subcontractor(s) only at the approval of Owner.** Contractor(s) and Subcontractor(s) of any tier must have submitted all necessary enrollment forms and have been accepted into the OCIP as evidenced by a confirmation of enrollment letter and issuance of OCIP “Certificates of Insurance”.
- 3.1.6 Participation in the OCIP is mandatory for ALL Contractors and their Subcontractors of any tier unless excluded by Owner or as outlined in Article 2.5. **However, enrollment is not automatic.** Work will not be permitted at the project site until the Contractor and Subcontractor, regardless of tier, is properly enrolled in the OCIP.
- 3.1.7 **OCIP Coverage applies only to work performed at the project site by the enrolled parties.** Enrolled parties must provide their own insurance for off-site activities including, but not limited to, work at their permanent shops, fabrication or manufacturing of building products, materials or supplies.

3.2 PROJECT ADMINISTRATION AND FORMS

- 3.2.1 The Contractor shall be responsible to manage and ensure the transmission of all administrative and safety documentation, including subcontractor insurance and payroll information, as required and directed by the Owner.
- 3.2.2 The Contractor and all enrolled Subcontractors shall include those administrative costs in the Construction Contract Limit (CCL) or Guaranteed Maximum Price (GMP) proposal which are necessary to properly comply with the Contract.

3.3 OCIP DOCUMENTATION COMPLIANCE

- 3.3.1 Failure by the Contractor and/or any Subcontractor to submit documentation and forms as directed by the Owner, or the OCIP Administrator, as described in Article 3.1 and 3.2 and in the Project Insurance Manual may result in an Owner-issued deductive Change Order to the Contractor for each delinquent document. The Contractor will be held accountable for all costs and schedule impacts associated with this action.
- 3.3.2 Persistent failures by the Contractor and/or any enrolled Subcontractors may result in a "stop work" order by the Owner. The Contractor will be held accountable for all costs and schedule impacts associated with this action.
- 3.3.3 **Payroll Reporting**—for insurance and program purposes, each contractor agrees to keep and maintain an accurate record of payroll for operations at the Project site. Enrolled subcontractors agree to furnish full and accurate payroll information and data via MWrap and in accordance with the requirements of the OCIP program and as detailed in the Project Insurance Manual.

Payroll must be submitted by Contractor and all tiers of enrolled Subcontractors via MWrap at each of the following occurrences:

- Monthly on or by the 10th of each month, following the end of the previous month.
- Final: Due upon completion of sublet work or at Project Substantial Completion, whichever occurs first.

The payroll will identify the Project site work-hours and payroll. Only the payroll of the Contractor and all enrolled Subcontractors' employees who perform duties at the Project site should be included on the payroll report.

Enrolled subcontractors who did not perform any work at the Project site in a given month must **still** submit a payroll form via MWrap showing zero (0) payroll and applicable completed contract value to date (if applicable) for the month.

Contractors and enrolled subcontractors with payroll reporting delinquent beyond 30 days will receive a Payroll Reminder Letter requesting response of activity in accordance with each contract under coverage.

The OCIP insurer is required to file experience data for each enrolled party with the appropriate rating authority. The loss experience of the Contractor and enrolled subcontractors for work performed on the Project site may affect the experience modification factor of that Contractor or enrolled subcontractor.

Contractor and enrolled subcontractors should exclude payrolls reported for work performed under the OCIP from payrolls submitted to their primary insurer to avoid duplicate premium charges. The insurance policies written by your primary insurance provider may need to be endorsed or modified to assist in this process.

3.3.4 Incident Notification and Claims Management:

3.3.4.1 Workers Compensation claims are to be initiated immediately by the employer, and shall always be within twenty-four (24) hours or one (1) work day of the occurrence, **or immediately upon acknowledgement of an injury from an employee**, whichever is later. The mechanism for initiating such a claim shall be the completion and transmittal of a “First Report of Injury” form (DWC Form 1) to the OCIP insurance carrier. Late reporting has been proven to substantially escalate the cost of claims and may therefore result in action on the part of the Owner to recover these avoidable costs from the Contractor by applying the following charges:

3.3.4.1.1 \$1,500.00 for reports that are 2 – 3 workdays beyond the date of occurrence

3.3.4.1.2 \$5,000.00 for reports that are 4 – 30 workdays beyond the date of occurrence

3.3.4.1.3 \$7,500.00 for reports that are 31 – 60 workdays beyond the date of occurrence

3.3.4.1.4 \$10,000.00 for reports that are more than 60 days beyond the date of occurrence

3.3.4.2 General Liability claims are to be initiated immediately and shall be within twenty-four (24) hours or one (1) workday of the occurrence, whichever is later. The mechanism for initiating such a claim shall be the completion and transmittal of a Notice of Occurrence / Claim form to the designated e OCIP administrative representative or as directed by the Owner. Late reporting has been proven to substantially escalate the cost of claims and may therefore result in action on the part of the Owner to recover these avoidable costs from the Contractor by applying the following charges:

3.3.4.2.1 \$1,500.00 for reports that are 2 – 3 workdays beyond the date of occurrence

3.3.4.2.2 \$5,000.00 for reports that are more than 3 workdays beyond the date of occurrence

3.3.4.3 General Liability – Property Damage:

- 3.3.4.3.1 If the Owner determines that the Contractor failed to take proper precautions prior to an incident that results in a property damage claim against the General Liability coverage, the Owner may recover from the Contractor the first \$5,000.00 of incurred cost against the claim.

3.4 WORKERS COMPENSATION PROCEEDINGS

- 3.4.1 The ODR may require the Contractor and/or the enrolled employer of an injured worker to provide knowledgeable representation at legally binding proceedings scheduled by the Texas Department of Insurance. The proceedings that affect the amount of compensation are “Benefit Review Conferences” and “Contested Case Hearings”. Failure to provide such representation may result in Owner issuance of a recovery charge to the Contractor of \$5,000.00 per proceeding.

3.5 EMPLOYEE RETURN TO WORK PLAN

- 3.5.1 The Contractor and every Subcontractor shall develop an Employee Return to Work (“Light Duty”) Plan that allows and encourages medically restricted workers to resume employment as soon as a physician assigns limits. The Plan shall include the following elements:

- 3.5.1.1 A written policy with signed acknowledgement from a Company Executive that declares intent to provide proactive safety prevention measures, immediate and appropriate medical care, aggressive claims management, and rapid return to work as critical elements of a successful safety and loss control program.

- 3.5.1.2 Job descriptions that clearly identify and explain essential job functions and tasks required for each position. Minimum physical limits, motor skills, and endurance times shall be included.

- 3.5.1.3 Procedures and responsibilities shall help physicians understand the Plan, the employee’s typical work assignments and activities, and available alternate assignments.

- 3.5.1.4 A commitment to the continuous employee education about the Plan, shall include monitoring of assignments, record keeping, and communications with physician(s) and injured worker(s), and tracking of compensation reports.

- 3.5.1.5 Full compliance with the Americans with Disabilities Act, Family Medical Leave Act, the Texas Worker’s Compensation Act, and any other State or federal law.

- 3.5.2 Employment for Workers with Medical Restrictions (“Return to Work” or “Light Duty” policy):

- 3.5.2.1 Either the absence of a written policy or the presence of a written policy that lacks a responsible commitment to restoring medically restricted workers to

gainful employment (considered to be at a similar work schedule and wage that was in effect at the time of the injury) may result in an assessment of a recovery charge by the Owner to the Contractor of \$5,000.00 per finding.

- 3.5.2.2 If the Owner determines that the Contractor or any enrolled Subcontractor deliberately obstructs a reasonable request that is intended to restore an injured worker to gainful employment, the Owner will assess a recovery charge against the Contractor of \$5,000.00 per claim per month until the worker is returned to employment. If the Contractor or enrolled Subcontractor believes that the medical restrictions prohibit gainful employment, the Contractor will be required to prove this to the Owner's satisfaction.
- 3.5.2.3 Failure to pass or refusal to take any substance impairment screening will result in Owner requirement that the involved worker be removed from the Project and not be allowed to work on any Owner Project.
- 3.5.2.4 The cost of all post-accident screening is the responsibility of the injured worker's employer.

3.6 EXPIRATION AND AVAILABILITY OF OCIP COVERAGE

3.6.1 Termination of OCIP Coverage

- 3.6.1.1 Except for Extended Completed Operations coverage or Extended Ongoing Operations coverage for Repair Work, the General Liability and Excess Liability insurance furnished by the Owner under this agreement will cease for the Contractor and each enrolled Subcontractor at the earlier of OCIP program expiration or when work called for in the Contract has been completed and accepted by the Owner. Workers Compensation coverage will continue until the earlier of OCIP program expiration or when work called for in the Contract has been accepted as identified in the Certificate of Substantial Completion issued by the Owner.

3.6.2 Availability and Cancellation

- 3.6.2.1 Subject to market availability, all insurance specified herein shall be maintained continuously until the scheduled completion/termination date. All insurance shall provide for Owner to take occupancy of the Work or any part thereof during the term of said insurance. If coverage is diminished or cannot be renewed due to market constraints and limitations, all insured Contractors will be notified within the ninety (90) day cancellation or non-renewal period as provided in the policies. Upon termination of the Owner-provided insurance, the Contractor and all enrolled Subcontractors shall be responsible for furnishing all insurance as described in the UGC and Article 2.3 above.
- 3.6.2.2 Owner-furnished insurance may also be discontinued in the event the Project is substantially delayed for an extended period of time, or the Project is permanently terminated for any cause.

END OF SECTION 00 73 16

REVISION LOG

The following is provided for convenience to the Owner, Architect/Engineer and Contractor to track changes between annual document issuances and is not to be considered by any party to be contractual or 100% complete.

Date	Paragraph Revised	
02/01/08	3.4 - Revised Texas Worker's Compensation Commission to Texas Department of Insurance.	
5/1/08	3.5.2 – Relocate Employment for Workers with Medical Restrictions (“Return to Work” or “Light Duty” policy)	
10/1/08	Title changed to “OCIP”, 2.1.2.3.2 – Change “3 years” to “10 years”, 2.1.2.4.1 change “\$25 M” extended coverage to “\$50 M”	
9/1/09	Corrected spelling of “SUBCONTRACTOR” in Article 2.2 and revised all Article 3.6 subsections.	
9/1/12	Clarifications of UGS abbreviation, exemption and drug testing clarifications and misc. clarifications.	
12/18/15	Compliance with SB 1081, attachment of the Project Insurance Manual template, policies, inclusion of Master Builders Risk language, and misc. revisions to align with current OCIP requirements.	
10/10/16	Replaced pages 57 through 95 with the current Workers Comp renewal policy. Corrected several misc. typos.	
12/12/16	Replaced Attachment A with current issue from ORM (Marsh contact info).	
8/1/17	Updated ROCIP with Phase VII changes and MWrap administrative process. Builder's Risk claims expenses process updated in 2.2.10.	
6/1/18	Formalized requirement to immediately report builder's risk claims in Section 2.2.13.	
9/1/18	Replaced Attachment A with current issue from ORM (Phase VII).	

SECTION 01 31 00 - PROJECT ADMINISTRATION

PART 1 - GENERAL

1.1. DEFINITIONS

1.1.1. The term “Architect” or ARCHITECT as used throughout the contract documents, is defined in the UGC.

1.1.1.1. On Design/Build contracts, the construction management staff may provide general administration, including management of meeting records and preparation of change orders, only with prior written approval of the Owner.

1.2. RELATED DOCUMENTS

1.2.1. In addition to specific references indicated herein, the Contractor's attention is specifically directed, but not limited, to the following Sections and Documents, which include additional administrative requirements.

1.2.1.1. Exhibit H - Policy on Utilization Historically Underutilized Businesses

1.2.1.2. Owner’s Special Conditions

1.2.1.3. Section 00 73 16 - Project Insurance Requirements – If applicable

1.2.1.4. Section 01 32 00 - Project Planning and Scheduling

1.2.1.5. Section 01 35 23 - Project Safety

1.2.1.6. Section 01 45 00 - Project Quality Control

1.2.1.7. Section 01 57 23 - Temporary Storm Water Pollution Control

1.2.1.8. Section 01 77 00 - Project Closeout Procedures

1.2.1.9. Section 01 91 00 - Project Commissioning

1.2.1.10. Section 23 00 00 - General Mechanical Requirements

1.2.1.11. Section 26 00 00 - General Electrical Requirements

1.3. CONTRACT SUBSTANTIAL COMPLETION

1.3.1. The terms “Substantial Completion” and “Pre-Final” shall be considered the same, and are used interchangeably throughout the Contract Documents.

1.3.2. In order to obtain a Substantial Completion inspection, the contractor shall fulfill all requirements as specified in the UGC and Specification Section 01 77 00 - Project Closeout.

1.4. PROCUREMENT OF SUBCONTRACTS (CONSTRUCTION MANAGER AT RISK AND DESIGN-BUILD AGREEMENTS ONLY)

1.4.1. The Construction Manager at Risk (CM) or Design/Build Contractor (DB) shall provide a written Bid/Proposal Package Strategy (B/PPS) for procuring subcontracts including self-performance work (other than General Conditions), prior to the approval of the Guaranteed Maximum Price, but no later than twenty (20) calendar days prior to the first advertisement for proposals. The B/PPS shall be a written plan submitted to, and reviewed by the ODR and the Architect.

1.4.1.1. The plan shall identify bid packages that are most advantageous to the project and align with the CM/DB's HUB Good Faith Effort (Exhibit H) by providing at least three (3) qualified respondents, including the CM/DB. Each bid package shall include the UGC, the Owner's Division 1 Specifications, Drawings and Specifications and any other UTHSCH requirements included in the CM/DB Agreement pertaining to the scope of work covered in the packages.

1.4.1.2. The B/PPS shall conspicuously identify any and all work that the CM/DB will submit a bid/proposal for, but will not perform with its own forces (i.e. subcontract to someone else if determined to be "best value").

1.4.1.3. The B/PPS shall include the following for each bid package contemplated:

1.4.1.3.1. Anticipated scope of work to be procured;

1.4.1.3.2. A current Work Progress Schedule;

1.4.1.3.3. Anticipated selection criteria and questions;

1.4.1.3.4. Self-perform work proposals to be submitted by the CM/DB;

1.4.1.3.5. Proposed advertising dates;

1.4.1.3.6. Proposed Pre-proposal meeting(s);

1.4.1.3.7. Exhibit H and Information on 00 73 16 Project Insurance Requirements (if applicable);

1.4.1.3.8. Proposed Receipt, review and award dates;

1.4.1.3.9. Anticipated notice to proceed dates.

1.4.1.3.10. To ensure compliance with SB 1081, all bid/proposals shall contain the following language on the signature page, "By signing this document, I acknowledge that this project will use a Contractor Controlled Insurance Program (CCIP) and I will participate in the program".

- 1.4.1.4. The CM/DB shall update the B/PPS monthly as a minimum, as conditions change, or as proposed dates are revised.
- 1.4.2. Per Texas Higher Education Code 51.782: “A construction manager-at-risk shall publicly advertise, in the manner prescribed by the institution, and receive bids or proposals from trade contractors or subcontractors for the performance of all major elements of the work other than the minor work that may be included in the general conditions”. This requirement applies to DB as well.
- 1.4.3. The goal of the project team shall be to have all work procured through advertised competitive proposals, however, if a “minor procurement” condition arises during the process, the following procurement guidelines may be used by the CM/DB, with Owner approval, for procurement of work:
 - 1.4.3.1. Less than \$5,000.00: No requirements
 - 1.4.3.2. Between \$5,000.01 and \$25,000.00: Obtain three (3) solicitations
 - 1.4.3.3. Greater than \$25,000.00: Obtain three (3) advertised competitive proposals
 - 1.4.3.3.1. If the CM/DB does not receive at least three (3) competitive proposals, the CM/DB shall re-package the scope and re-issue without additional cost to the Owner or delay to the project “Substantial Completion” date (unless approved by the Owner).
 - 1.4.3.3.2. If the CM/DB receives less than three (3) competitive proposals and the ODR determines that specific factors related to the project’s schedule or quality do not require re-issuance, the CM/DB shall provide the ODR with a letter stating the CM/DB does not have any ownership interest in, or a controlling relationship with, the recommended “best value” vendor.
 - 1.4.3.3.2.1. If the CM/DB cannot provide a letter, the package shall be re-issued without additional cost to the Owner or delay to the project “Substantial Completion” date, unless otherwise approved by the Owner.
- 1.4.4. This specification does not pertain to Change Orders to existing subcontracts.
- 1.4.5. Work shall be divided into reasonable lots; however, material or labor acquired through purchase order/vendor type agreements are subject to the entire project (i.e. Concrete material shall be procured as a unit price times an estimated total project quantity provided by the CM/DB to equal a total construction cost). Work shall not be incrementally divided for the purpose of circumventing the procurement guidelines.

- 1.4.6. The CM/DB may establish selection criteria for each phase of work for review by the project team. Criteria shall be qualifications based and consistent with the information needed by the CM/DB to make a proper evaluation and selection. The CM/DB shall establish a selection matrix including cost, criteria, weighting and ranking procedures for evaluation. The CM/DB shall work with the project team to tailor the selection criteria to be project and scope specific, and ensure that the questions are proper and relevant to the goals of the project. The CM/DB shall follow the Good Faith Effort requirements identified in Exhibit H of the Agreement, including attachments to be completed by 1st tier subcontractors. However, HUB participation/status cannot be used as criteria for determining “best value”, only for determining if the respondent is responsive.
 - 1.4.6.1. The CM/DB shall establish clear criteria and questions so that those reading the Request for Proposals will understand how they will be evaluated.
 - 1.4.6.2. If criteria are not included in the advertisement for proposals, the proposal shall be considered a lump sum bid, and the CM/DB shall award the work to the lowest qualified, responsive bidder.
 - 1.4.6.3. After selection criteria have been established, the CM/DB shall publicly advertise the work in general circulations and trade associations in accordance with TEC 51.782 for CM, Article 7 of the current Agreement for DB and Texas Administrative Code 111.14 – “HUB” for both CM and DB. This advertisement shall include, at a minimum, the following:
 - 1.4.6.3.1. OFPC Project Number and Project Name;
 - 1.4.6.3.2. Institution/Campus name;
 - 1.4.6.3.3. CM/DB name and address;
 - 1.4.6.3.4. CM/DB contact name and phone number;
 - 1.4.6.3.5. Location for viewing plans and specifications;
 - 1.4.6.3.6. Date, time and location of Pre-proposal meeting;
 - 1.4.6.3.7. Date, time deadline(s), and location for receiving proposals;
 - 1.4.6.3.8. Instructions to respondents for submitting proposals;
 - 1.4.6.3.9. Selection criteria, questions and submittal requirements.
- 1.4.7. At the time and location identified in the advertisement, the CM/DB shall hold a Pre-proposal meeting for all potential subcontractors with the project team and Owner’s HUB Coordinator. The CM/DB shall review as a minimum:

- 1.4.7.1. The general scope of the project and the specific scope of work included in this package;
 - 1.4.7.2. Instructions to respondents for submitting proposals;
 - 1.4.7.3. Selection criteria and questions;
 - 1.4.7.4. HUB Good Faith Effort requirements (Exhibit H);
 - 1.4.7.5. Project Safety requirements;
 - 1.4.7.6. OCIP requirements (if applicable);
 - 1.4.7.7. Project Schedule requirements;
 - 1.4.7.8. Payment procedures and requirements, including retainage;
 - 1.4.7.9. Commissioning and Close-out requirements.
- 1.4.8. If the CM/DB identifies any self-performance in the B/PPS (work to be performed by its own employees), the CM/DB shall submit a proposal to the Owner at the advertised time and location in a manner so as not to compromise the competitive process.
- 1.4.8.1. Regardless of the work or method of accepting proposals, all CM/DB self-performance proposals shall be:
 - 1.4.8.1.1. Estimated and submitted by a separate estimating team that is not associated with the CM/DB's pre-construction and/or construction team;
 - 1.4.8.1.2. Submitted in a sealed envelope;
 - 1.4.8.1.3. The final proposal price and not subject to change for any reason prior to recommendation of subcontract award.
- 1.4.9. The CM/DB shall accept all proposals at the advertised location until the advertised deadline. Upon receipt, the ODR shall be allowed to review the proposal and confirm the time and date received. Any proposals received after the deadline shall not be considered by the CM/DB, and shall be returned to the respondent unopened.
- 1.4.9.1. Fax proposals shall not be accepted unless the Owner, prior to the initial advertisement for proposals, approves a detailed plan by the CM/DB of care and custody.
- 1.4.10. After compiling, reviewing and verifying the costs and scope associated with all proposals, the CM/DB shall provide a "bid tabulation" matrix and a proposed

Schedule of Values ((refer to Attachment C (CSP format) or D (CM and DB format)) for review by the project team.

- 1.4.10.1. The “bid tabulation” matrix shall compare all equivalent scope proposals to the CM/DB’s estimate.
 - 1.4.10.2. Each matrix shall indicate the CM/DB estimate(s) for each scope of work and identify the respective cost savings/over-runs.
 - 1.4.10.3. The CM/DB may use values/quantities from its own estimate to provide full scope comparisons between each respondent, however, these “plug” numbers shall be clearly identified in the matrix to the project team and be used only to compare the various proposals.
 - 1.4.10.4. The proposed updated Schedule of Values shall summarize all executed and recommended “best value” subcontracts to provide a current status of the Guaranteed Maximum Price Proposal.
 - 1.4.10.5. Once the proposals are compiled into a “bid tabulation” matrix and the proposed Schedule of Values has been updated, the CM/DB shall request a meeting with the project team to review the proposals.
- 1.4.11. The CM/DB shall lead the proposal review meeting by reviewing the scope of work, the proposals received, any exclusions or conditions, identify any non-qualified respondents and any other problems that may have occurred during the process.
- 1.4.11.1. The CM/DB shall confirm that the respondents are qualified, meet the established selection criteria (if applicable), and identify the amount of the proposals.
 - 1.4.11.2. The CM/DB shall identify the “best value” and the current status of the buy-out savings to the project team. If the “best value” causes the CM/DB to exceed the Cost of Work line item, including contingencies in the GMP the CM/DB shall acknowledge that the overage will be deducted from the CM/DB’s Construction Phase Fee.
- 1.4.12. Once the “best value” respondent has been identified by the CM/DB, without exception (or as noted) by the Owner, the CM/DB shall finalize negotiations with the selected “best value” respondent.
- 1.4.12.1. The CM/DB shall identify and confirm with the ODR which competitive proposal “plug” numbers it intends to use in its negotiations. “Plug” numbers may be established through the CM/DB’s own estimate (if turned into the ODR before the advertised deadline) or values included in other non-selected respondent competitive sealed proposals.

- 1.4.12.2. If the CM/DB cannot reach an agreement with the selected respondent, the CM/DB shall notify the ODR that it intends to begin negotiations with the second “best value” respondent.
- 1.4.12.3. The CM/DB shall issue a letter to the Owner indicating that it intends to write a subcontract to the selected “best value” respondent (including self-perform work), identifying the following:
 - 1.4.12.3.1. The bid package number;
 - 1.4.12.3.2. The base bid from the selected respondent and any alternates included in the proposal;
 - 1.4.12.3.3. The total value of the proposed subcontract with a description of any changes from bid day values;
 - 1.4.12.3.4. Drawings and/or specifications related to the subcontract;
 - 1.4.12.3.5. Additional scope items added to the subcontract (as previously agreed to by the Owner), and their value;
 - 1.4.12.3.6. Current status of the GMP identifying current savings/overages;
 - 1.4.12.3.7. A copy of the bid tabulation matrix;
 - 1.4.12.3.8. A copy of the executed subcontract or purchase order, etc. is required prior to any request for payment by the CM/DB for applicable work.
- 1.4.12.4. If the Owner objects to the “best value” identified by the CM/DB, the Owner may conduct an evaluation of the selection process and/or results.
 - 1.4.12.4.1. If, after evaluation, the ODR disagrees with the CM/DB “best value” recommendation, the ODR may instruct the CM/DB to either re-bid the scope of work or use the Owners’ “best value” selection.
 - 1.4.12.4.2. If the value of the Owners’ selection causes an increase in the Total Contract Price, the increase will be the responsibility of the Owner.
- 1.4.12.5. The CM/DB shall provide one (1) complete copy of all recommendation letters and proposals to the ODR for record, as they occur until final payment.
- 1.4.13. For additional bid packages, the CM/DB shall repeat the steps identified in this section as many times as identified in the current B/PPS for the entire project.

1.5. SUBCONTRACTS

- 1.5.1. **Contractor agrees to bind every subcontractor, and every subcontractor agrees to be bound by all the terms and conditions of the Owner's Contract.**
- 1.5.2. The Contractor is required to submit a list of all first tier subcontractors to the Owner as subcontracts are executed.
- 1.5.3. **All subcontractor procurement strategies, procedures and documents issued by the Contractor shall comply with, and enforce the Project Safety, 00 73 16 Project Insurance Requirements and UT System Historically Underutilized Business requirements referenced above.**

1.6. FLOW OF COMMUNICATIONS

- 1.6.1. The Architect is responsible for document control and general project administration. The Owner's written instructions to the Contractor will generally be issued through the Architect. The Architect is the key contact for written communications.
 - 1.6.1.1. On Design-Build projects, the construction management staff may provide this service if approved by the Owner prior to the Notice to Proceed for Construction Services.
- 1.6.2. All subcontractor correspondence shall be routed through the Contractor. All written Contractor correspondence is to be directed to the Architect, with simultaneous copies to the Owner's Designated Representative (ODR) and Construction Inspector(s) (CI). The actual parties for this project will be confirmed at the Pre-Construction Conference.
- 1.6.3. The ODR and the CI are the Owner's primary representatives for the Project. The CI is the key contact for verbal communications and site issue coordination.
- 1.6.4. The ODR and the CI are the only parties authorized to direct changes in the work, and issue written and/or oral instructions directly to the Contractor.
 - 1.6.4.1. All ORAL instructions must be issued by the ODR and/or the CI, or in their presence, and shall be promptly confirmed in writing by the Contractor. Any oral instructions or discussions with subcontractors in the absence of the Contractor are not contractual and are not binding on either party.
- 1.6.5. The Architect may issue clarification and other information not affecting the contract cost or time by means of an Architect's Supplemental Instruction form, (ASI), or similar clarification form and will be sequentially numbered. Both the Architect and the Contractor shall maintain a separate ASI/PR register.
 - 1.6.5.1. If the Contractor considers such clarification to be a change in the contract scope, written notification of such must be provided before performing the work considered to be a change within thirty (30) calendar days of Contractor's receipt, or with the Change Order Proposal.

- 1.6.6. All subcontractor Requests for Information, (RFI), are to be submitted by and under cover of the Contractor, who is to carefully review and ensure the completeness and appropriateness of the question, sequentially number each, and submit to the Architect with copies to the ODR and CI. The Contractor and Architect shall maintain separate RFI logs.
 - 1.6.7. All project correspondence shall include UTHSCH Project Number and Project Name in the title or reference.
 - 1.6.8. Pay Estimates, Requests for Information, Changes, Submittals, etc... are to be processed as instructed by the ODR in the Pre-Construction Conference.
- 1.7. PROJECT CHANGES
- 1.7.1. All changes shall be administered per the UGC.
 - 1.7.2. All changes to the contract affecting cost, scope and/or time will be issued as a formal Change Order to the Contract on the standard University of Texas System Change Order form. The Change Order may include separate change issues, identified as Change Order Proposals and Field Orders.
 - 1.7.3. Upon authorization by the Owner, Change Order Proposals may be issued to the Architect for pricing by the Contractor. All contractor pricing shall be submitted on the standard UTHSCH "Change in Work Cost Analysis" ("Cost Analysis") form provided by the project manager. Prior to its inclusion in a Change Order, the Owner must accept a Change Order Proposal. When the Owner has approved a Change Order Proposal it will be included in a Change Order for execution.
 - 1.7.3.1. The Contractor shall summarize all costs for each change at each level of subcontractor and supplier by preparing the "Cost Analysis" form, and shall provide each subcontractor's cost summary on separate "Cost Analysis" forms as backup. Additional support documentation from both the Contractor and its subcontractors is encouraged, but such will not replace use of the standard U.T. System form.
 - 1.7.3.2. Where the Contractor believes it is entitled to a time extension, it shall so state as part of its response to the Change Proposal, including a justification for such request. Time extensions will be granted only if a Change Order Proposal affects the activities on the Critical Path of the Owner approved Project Schedule (i.e., when the work impacts the "Contract Substantial Completion Date").
 - 1.7.3.3. If the Owner and Contractor cannot mutually agree upon a fair and reasonable cost and time settlement, the Owner may: 1) Reject the quotation and void the Change Order Proposal, 2) Issue instructions to the Contractor to proceed on a time and material basis for a price to be determined later not to

exceed a fixed maximum dollar and time, or 3) Issue a Unilateral Change Order.

- 1.7.3.4. The Owner may issue Field Orders directly to the Contractor for minor changes to the contract, which can be negotiated in the field. Pricing backup shall be the same as a Change Order Proposal and is to be outlined on the "Cost Analysis" form noted above. Once the Owner and the Contractor have signed the Field Order, the work is authorized and the Field Order will be included in the next Change Order.

1.8. LIQUIDATED DAMAGES

- 1.8.1. If assessed, liquidated damages will be withheld from progress payments beginning with the first payment after the adjusted Contract completion date and until all work of the contract is complete. The amount assessed shall be deducted from the contract price through a written Change Order.

1.9. SITE USE ISSUES

- 1.9.1. Harassment of any kind toward any person will not be tolerated; offending workers will be removed from the project immediately and permanently.
- 1.9.2. The Contractor shall provide and submit a program plan for worker orientation, identification and control of access to the site. All workers on the project shall participate in this program before beginning work on the project. This plan shall include, as a minimum:
 - 1.9.2.1. Employee identification badges with a photograph of the employee, the employer and employees' name. Badges shall be provided for all employees and produced by a system on site. This identification shall be worn at all times while on the project site. Lack of an ID badge shall be grounds for removal from the project until badge is produced.

PART 2 - PRODUCTS

2.1 SHOP DRAWINGS AND SUBMITTALS

- 2.1.1 Refer to the UGC for requirements not identified in this section.
- 2.1.2 The Contractor shall assign an identifying number to each submittal following a format to be established at the Pre-Construction Conference. The same number with a numerical or alphabetical suffix will be used to identify re-submittals.
- 2.1.3 The burden of timeliness to complete the submittal process is on the Contractor. The Contractor shall allow sufficient time within the construction schedule to the

Architect and Owner to review and approve all submittals, including time for all re-submittals on any unaccepted/rejected submittal.

- 2.1.4 Any deviation from the Contract Documents shall be conspicuously noted on the submittal and the transmittal cover sheet. Failure to so note deviation will void any action taken on the submittal.
- 2.1.5 All manufacturer's data contained within the submittal shall have all inapplicable features crossed out or deleted in a manner that will clearly indicate exactly what is to be furnished.
- 2.1.6 Equipment of larger sizes than shown, even though of a specified manufacturer, will not be acceptable unless it can be demonstrated that ample space exists for proper installation, operation, and maintenance.
- 2.1.7 The Owner will not be responsible for payment of any item that has not been submitted and approved through the established submittal process.
- 2.1.8 The Contractor shall anticipate the electronic delivery of all submittals directly to the architect with copy to ODR, CI and other designees per the Pre-Construction Conference.

2.2 SUBSTITUTION OF MATERIALS, LABOR AND EQUIPMENT

- 2.2.1 Refer to the UGC for requirements not identified in this section.
- 2.2.2 The specified products referenced in the Contract Documents establish minimum qualities for which substitutions shall at least equal to be considered acceptable. The burden of proof of equality rests with the Contractor. The Owner retains sole authority for acceptance of substitutions.
- 2.2.3 All substitutions shall be submitted within ninety (90) days of the Notice to Proceed for Construction and clearly marked as such on the transmittal cover sheet for the submittal.
- 2.2.4 The Contractor shall allow a minimum of six (6) weeks for review of each substitution by the Architect and/or Owner in addition to the requirements identified in Section 2.2.3 above.
- 2.2.5 When requested by the Architect, the Contractor shall provide a sample of the proposed substitution item. In some cases, samples of both the specified item and the proposed item shall be required for comparison purposes.
- 2.2.6 Acceptance of materials and equipment will be based on the supplier / manufacturer's published data and will be tentative subject to the submission of complete shop drawings and/or specifications indicating compliance with the

Contract Documents. Acceptance of materials and/or equipment under this provision shall not be construed as authorizing any deviation from the Contract Documents, unless specifically directed in writing from the Architect.

2.2.6.1 Any and all additional costs or time resulting from the acceptance or rejection of any substitution shall be the sole responsibility of the Contractor. These include costs that are not presented at the time of the substitution request and those costs that become known after the approval of the substitution. This includes direct as well as indirect costs.

2.2.7 If a substitution is accepted, and the substitute proves defective, or otherwise unsatisfactory as determined by the Owner for the service intended within the guarantee period, the substitute shall be replaced with the material or equipment specified in the Contract Documents, or as approved by the Owner, at no additional cost to the Owner.

2.3 INITIAL APPLICATION FOR PROGRESS PAYMENT

2.3.1 The Contractor shall submit an initial request for a progress payment per the UGC.

2.3.2 Such requests shall be presented on the standard AIA application for payment with previously approved Schedule of Values unless instructed to use another format by the ODR in the Pre-Construction Conference.

2.3.3 The Contractor's Project accounting records shall be kept on the basis of generally accepted accounting principles in accordance with cost accounting standards issued by the Federal Office of Management and Budget Cost Accounting Standards Board and organized by each Application for Payment period.

2.3.4 Prior to the submission of the initial Application for Payment the Contractor shall submit the following documents to the Architect, Owner for review:

2.3.4.1 Contract Price or GMP Schedule of Values: A single document itemizing the breakdown of the Contract Price/GMP, including general conditions, contingencies and allowances shall be submitted using the OFPC Standard Schedule of Values format. The Contractor shall submit a draft breakdown and such submittal shall be a condition precedent to the processing of the first payment application. The Contractor shall submit subsequent draft copies of the Schedule of Values no later than five (5) working days prior to formal submission of each monthly payment.

2.3.4.1.1 The breakdown shall follow the trade divisions of the specifications and shall be itemized by submittal, floor, area, elevation or other building systems, as a minimum. The breakdown shall include a labor and material breakdown for each activity and be of such detail as may be required by the Owner and/or Architect, but in general

shall limit each line item to less than \$100,000, or as approved by the Owner.

2.3.4.1.2 No adjustment to the original detailed breakdown of a contract line item shall be made once accepted by the Owner and Architect. Once accepted, the breakdown will form the basis for all periodic payments.

2.3.4.1.2.1 Contracts with Construction Manager at Risk or Design/Build Agreements may adjust the detailed breakdown of a General Conditions line item if the total invoices for a General Conditions line item exceeds one hundred percent (100%). A corresponding amount shall be deducted from another General Condition line item(s) or the Construction Phase Fee to pay for the overage.

2.3.4.1.3 The Contractor shall not use subcontractor invoices/pay applications in lieu of a single Schedule of Values from the Contractor.

2.3.4.1.4 The breakdown shall anticipate future Change Orders and make provisions for incorporating all changes into the breakdown listing. If issued, Change Orders shall be identified separately and shall itemize the GMP Change Orders, Change Proposals and/or Field Orders, which are incorporated into each Change Order for payment on a line-item basis as required by this section.

2.3.4.1.5 Contracts with Guaranteed Maximum Price proposals shall repeat the process outlined in this section every time a subcontract is added to the monthly Schedule of Values for payment.

2.3.4.2 Work Progress Schedule: Refer to specification section 01 32 00 for all project schedule requirements.

2.3.4.3 Shop Drawing/Submittal Schedule: The Contractor is to provide the Owner and Architect with a Submittal Schedule of all items requiring submittal review showing their anticipated submission date and late finish date for completion of the review process. This Schedule shall be incorporated with the Work Progress Schedule, and each will be updated monthly and submitted to the Architect and Owner with each draft payment request.

2.3.4.4 Equipment List/Matrix: Specification Sections 01 91 00 and 23 00 00 require a matrix of all operable devices, building system components and mechanical equipment be submitted at least one week prior to the first application for progress payment. These lists may be combined and, further, may be incorporated into equipment documentation required in Operating and Maintenance Manuals as indicated in Specification Section.

- 2.3.4.5 The Contractor is encouraged to integrate these documents to the extent practical to avoid duplication, both in initial setup and ongoing updates to each.
- 2.3.5 Once the line item amounts are agreed to by the Owner and the Contractor, the Contractor is to submit an electronic copy of the formal application to the Architect, utilizing the designated form, with original signatures of an officer of the contracting firm and original notarization. The Contractor shall furnish a certificate designating a person(s) who has authority to sign pay applications on behalf of the firm if such is not an officer of the firm.
 - 2.3.5.1 At a minimum, the Contractor shall provide attachments to each month's payment request as follows:
 - 2.3.5.1.1 A copy of the monthly HUB Progress Assessment reports (Attachment H to Exhibit H)
 - 2.3.5.1.2 A copy of the updated Submittal Schedule
 - 2.3.5.1.3 A copy of all invoices required by the contract.
 - 2.3.5.1.4 A copy of the wage rate notification form for each member of the workforce not previously submitted.
 - 2.3.5.1.5 A copy of the updated Work Progress Schedule as specified in Specification Section 01 32 00.
- 2.4 MONTHLY APPLICATION FOR PROGRESS PAYMENTS
 - 2.4.1 For regular monthly applications for payment, the Contractor shall submit for review and approval a draft payment request to the ODR, CI, and the Architect no less than five (5) working days prior to formal submission. The Contractor shall be prepared to review the draft copy at the project site with the Owner and the Architect. Failure to comply with the requirements outlined in Section 2.3 above shall relieve the Owner from its obligation to make payments on any/all line items until the Contractor meets all requirements.
 - 2.4.1.1 Payments cannot exceed the contract, work in-place, or subcontract amounts as depicted on Schedule of Values line items.
 - 2.4.1.2 All as-built drawings shall be reviewed to ensure updates are current.
 - 2.4.1.3 Retainage shall not be used to cover "punch-list" work items.

- 2.4.1.4 All off-site stored materials shall be specifically identified, including the required documentation, photographs, insurance and arrangements for the Contractor to escort the CI to visit and personally verify the stored material is physically separated and secure from other material.
 - 2.4.2 Requests for payments in association with release of, or reduction in retainage or completion of work have additional requirements as outlined in the UGC and Specification Section 01 77 00.
 - 2.4.3 The Owner may withhold Progress Payments in accordance with the UGC.
 - 2.4.4 The Owner's Designated Representative shall determine acceptance of either mailed or electronically submitted invoices. The payment due date is when the invoice can be viewed by an employee on the first business day following the submittal, if the agency receives the invoice after normal business hours.
- 2.5 CONTRACTOR'S DAILY REPORT
- 2.5.1 The Contractor shall provide the Architect, ODR and CI with a report detailing its daily activities on the Project in a format acceptable to the Owner. All tests performed by the Contractor are to be attached. All work reports required of subcontractors shall be attached to the Contractor's daily report.
 - 2.5.1.1 The report shall include, as a minimum, the following information as it relates to the day's activities on site: subcontractors on site (including number of employees for each sub), equipment, areas of work and type of work performed, material received, tests performed, any injuries and/or accidents, total number of employees on site (including Contractor) any oral instructions received, any material damage, any change in personnel and anything else that might impact quality or schedule.
 - 2.5.2 These reports shall be submitted to the CI on a daily basis, and are ground for withholding payment.
- 2.6 AS-BUILT DRAWINGS AND RECORD DOCUMENTS
- 2.6.1 "As-Built" drawings, specifications, detail manuals, and submittals shall be continuously annotated by the Contractor to reflect actual record conditions, addenda, issuance of all Change Orders and clarifications, and actual dimensional records for underground and all other services.
 - 2.6.2 Maintenance of current documentation by the Contractor is required in order to process pay applications. The CI and the Architect will review the status of such documentation monthly, at a minimum.
 - 2.6.3 Refer to Specification Section 01 91 00 – Project Commissioning for requirements regarding the Commissioning and Closeout Manual tracking of these documents.

- 2.6.4 Refer to Specification Section 01 77 00 – Project Closeout Procedures for detailed instructions on As-Built Drawings, Specifications, O&M manuals and other records.

PART 3 – EXECUTION

3.1 PRE-CONSTRUCTION CONFERENCE (WITH OR WITHOUT A PARTNERING WORKSHOP)

- 3.1.1 A Pre-Construction Conference will be held no more than two weeks after notice to proceed. The agenda will be distributed by the ODR one week prior to the conference scheduled date and will include key project personnel, directions for documentation routing, Owner's sample administrative forms, and other information will be conducted at the conference.
- 3.1.2 Upon mutual agreement, a Partnering Workshop may be held with or near the time of the Pre-Construction Conference. The Preconstruction Conference and/or Partnering Workshop will be paid for in total by the Contractor, and reimbursed by the Owner for fifty percent (50%) of the mutually agreed upon costs (100% of the costs shall be reimbursed to the Contractor as part of the General Conditions in the GMP for CM and DB contracts).
- 3.1.2.1 The conference and/or workshop is intended to provide further understanding among the parties, to establish mutual goals for the project and to develop strategies for achieving those goals.
- 3.1.3 The Owner will schedule a Pre-Construction Conference to generally coincide with issuance of Notice to Proceed for Construction. The conference agenda will cover broad project issues followed by detail review of administrative procedures.
- 3.1.3.1 The UGC requires the Contractor to comply with the Owner's administrative requirements as outlined herein and as reviewed at the Pre-Construction Conference.
- 3.1.3.1.1 For projects with Guaranteed Maximum Price contracts the Owner may require a Pre-Construction meeting prior to Notice to Proceed Construction.
- 3.1.3.1.2 For projects with Guaranteed Maximum Price contracts and multiple bid packages, the Owner may schedule additional Pre-Construction Conferences to include any subcontractors added to the project after the initial Pre-Construction Conference.
- 3.1.4 Attendance may be required as determined by the Owner at the conference by all appropriate representatives of the Contractor, mechanical, electrical, plumbing subcontractors, and any additional subcontractors (proposed or engaged), whose scope of work represents five percent (5%) or more of the total construction cost. The Contractor shall request all HUB subcontractors also be represented. Each firm is to be represented by personnel directly involved in the Project, including Project

Managers and Project Superintendents or labor foremen, as a minimum.

3.1.4.1 Project representatives of the Contractor and all other parties directly involved with the processing or executing of project submittals, changes and/or payments should attend the conference.

3.1.5 Prior to the scheduled time of the Pre-Construction Conference, the Contractor is to provide the Architect a written outline of all involved firms, their key personnel, including mailing address and phone numbers to be incorporated into a Project Directory and included in the Pre-Construction Agenda.

3.2 PROJECT PROGRESS MEETINGS

3.2.1 In addition to specific coordination meetings, pre-installation contractor meetings for each element of work, and other project meetings for other purposes; the Contractor will schedule and conduct a Project Progress Meeting, monthly, twice-monthly, or weekly, as conditions may dictate.

3.2.2 Prior to the Project Progress Meetings, the Contractor shall convene a similar progress meeting with their subcontractors to review each of their present and future needs including interface requirements, utility outages required, sequences, deliveries, access, site utilization, temporary facilities and services, hours of work, hazards and risks, housekeeping, change orders, and documentation of information for payment requests in order to be fully prepared to discuss all pertinent issues with the Owner. The Contractor is to notify the Owner and Architect in advance of such meetings with subcontractors.

3.2.3 Project Progress Meetings are to include review of Contractor's updated Critical Path Method (CPM) schedule and forecast of operations for coming period, as well as issues of coordination, anticipated utility outages, status of requested change proposals and other cost impact issues, status of the Commissioning process, status of the HUB Plan, and other project issues

3.2.4 The Contractor shall provide separate tracking logs for submittals, RFIs, ASIs, and changes in a package for each primary meeting participant. On Design/Build contracts, a single set of tracking logs may be utilized if accepted in advance by the Owner.

3.2.5 This meeting will be chaired by the Contractor's project leadership. The Contractor shall be specifically prepared to discuss the following at each Progress Meeting:

- 3.2.5.1 Status of all activities appearing on the current Longest Path Bar Chart and the Three Month Rolling Schedule as required in Specification Section 01 32 00 – Project Planning and Scheduling;
 - 3.2.5.2 Status of Project Safety;
 - 3.2.5.3 Status of "action" items from the previous meeting;
 - 3.2.5.4 Status of Buyout on Guaranteed Maximum Price projects;
 - 3.2.5.5 Current status of product submittals and shop drawings, requests for information (RFI), and Architect's clarifications (ASI);
 - 3.2.5.6 Status of project changes and other items of significance, which could affect progress;
 - 3.2.5.7 Status of the Commissioning process for the project;
- 3.3 UTILITY OUTAGES
- 3.3.1 The Contractor shall notify the CI and the ODR, in writing, of any planned utility outages ten (10) calendar days in advance for academic and office campuses and not less than three weeks for all medical or research campuses.
 - 3.3.2 A standard form for processing a request for utility shutdown or any other campus disruption is provided by the ODR. The Contractor shall utilize this form, with attachments as necessary, in requesting an outage.
- 3.4 The Contractor shall not turn service on or off, without prior written authorization. Unless directed otherwise, the campus Physical Plant will turn services on and off.
- 3.5 TESTING
- 3.5.1 Refer to the UGC and Specification Section 01 45 00 for additional requirements.
 - 3.5.2 The Contractor shall not employ the same testing entity engaged by the Owner.
- 3.6 INSPECTIONS
- 3.6.1 Refer to the UGC and Specification Section 01 45 00 for inspection requirements.
- 3.7 FINAL ACCEPTANCE AND PAYMENT
- 3.7.1 The Contractor must notify the Architect, Owner, in writing that the Work will be ready for final acceptance verification on a definite date, a minimum of ten (10) calendar days prior to such proposed date.
 - 3.7.2 In addition to requirements noted for Substantial Completion, final payment and/or release of remaining retainage requires submission of the following:

- 3.7.2.1 Consent of Surety;
 - 3.7.2.2 Release of Liens and Claims;
 - 3.7.2.3 Affidavit of payment of Debts and Claims;
 - 3.7.2.4 Final Historically Underutilized Business Plan;
 - 3.7.2.5 Completed and signed SWPPP Notice Of Termination;
 - 3.7.2.6 Closeout of the Owner's Construction Contingency and/or Owner's Special Cash Allowance to a zero (\$0) balance.
- 3.7.3 Refer to UGC and Section 01 77 00.

3.8 ONE YEAR WARRANTY

- 3.8.1 If informed of a defect, the Contractor shall remedy the defect at its own cost and respond in writing to the ODR and the notifying party within ten (10) calendar days indicating the action taken to resolve the defect. Refer to the UGC.
- 3.8.2 The Contractor shall attend any and all meetings to resolve warranty issues. The Contractor will provide a tracking log of all warranty issues, and their resolution.
- 3.8.3 The Contractor shall participate in an end of warranty project review with the Owner, as scheduled by the ODR, at a time prior to termination of the warranty period.
- 3.8.4 Per the UGC and unless directed in writing by the Owner, all warranties shall use the date of Substantial Completion as the start date for that particular warranty.
 - 3.8.4.1 If any equipment and/or system is completed prior to the date of Substantial Completion, the Contractor shall provide, at their own cost, for the necessary warranty extension as required to meet the requirements of the UGC.
 - 3.8.4.2 All equipment shall be delivered to the Owner in an "as-new" condition. If equipment is put into service for the convenience of the contractor, the contractor shall, at their own expense, maintain, service and refurbish the equipment to "as-new" condition prior to delivery to the Owner.

END OF SECTION 01 31 00



The University of Texas
Health Science Center at Houston

REVISION LOG

The following is provided for convenience to the Owner, Architect/Engineer and Contractor to track changes between annual document issuances and is not to be considered by any party to be contractual or 100% complete.

Date	Paragraph Revised	

SECTION 01 32 00 - PROJECT PLANNING AND SCHEDULING

PART 1 - GENERAL

1.1. DEFINITIONS

- 1.1.1 The term “Baseline Schedule,” as used throughout the contract documents, shall refer to a fixed projection of the project schedule. It is the standard by which project performance is measured.
- 1.1.2 The term “Calendar Day,” as used throughout the contract documents, is any day of the week, including weekends and holidays.
- 1.1.3 The term “Construction Schedule” (a.k.a. Work Progress Schedule as defined by the UGC), as used throughout the contract documents, shall refer to the schedule for the construction phase of the Project as developed, monitored and maintained, by the Contractor’s Scheduler, and as used by the Project Team during Pre-Construction and/or Construction Services.
- 1.1.4 The term “Critical Path,” as used throughout the contract documents, shall refer to the sequence of activities that determines the longest duration for the Project when the Longest Path has zero or less Total Float, the Longest Path becomes the Critical Path.
- 1.1.5 The term “Critical Path Method” (CPM), as used throughout the contract documents, is a technique used to predict project duration by analyzing which sequence of activities has the least amount of scheduling flexibility. Early dates are figured by a forward pass using a specific start date and late dates are figured by using a backward pass starting from a completion date. Most scheduling programs (e.g., Microsoft Project, Primavera) automatically calculate the Longest Path using the CPM to identify critical activities.
- 1.1.6 The term “Data Date,” as used throughout the contract documents, shall refer to the day after the date through which a schedule is current. Everything occurring earlier than the data date is "as-built" and everything on or after the data date is "planned."
- 1.1.7 The term “Detailed Schedule,” as used throughout the contract documents, shall refer to a schedule with small-scale, well-defined activities that are typically less than 30 calendar days in length.
- 1.1.8 The term “Fragnet,” as used throughout the contract documents, shall refer to a copy of the Construction Schedule (or portion thereof) used to conduct an analysis of proposed changes or revisions to the Construction Schedule.
- 1.1.9 The term “Free Float,” as used throughout the contract documents, is the time by which an activity may be delayed or extended without affecting the start of any succeeding activity. Note: Free float can never be negative.

- 1.1.10 The term “Longest Path,” as used throughout the contract documents, shall refer to the sequence of interdependent activities that aggregate to determine the minimum duration of a project.
- 1.1.11 The term “Milestone Schedule,” as used throughout the contract documents, shall refer to a schedule with specific non-duration related activities, work packages, stages, or phases, typically marked by a high level event such as an approval, execution of a contract, Notice to Proceed, issuance of a set of documents, completion of work, etc.
- 1.1.12 The term “Precedence Diagramming Method” (PDM), as used throughout the contract documents, shall refer to the relationship between activities by linking sequences with precedence relationships in the development of the Construction Schedule.
- 1.1.13 The Term “Project” means all activities necessary for the realization of the Work. This includes design, contract award(s), execution of the Work itself, and fulfillment of all contract and warranty obligations.
- 1.1.14 The term “Project Team,” as used throughout the contract documents, shall refer to the Owner, Architect, Design Consultants, User, Contractor and Subcontractors (as applicable) that are contracted and/or specifically assigned to the Project.
- 1.1.15 The term “Total Float,” as used throughout the contract documents, shall refer to the time by which an activity may be delayed or extended without affecting the total project duration or violating a target finish date (i.e. Substantial Completion Date).
- Negative Total Float indicates that the Project is late, while Positive Total Float is the property of the Project and does not belong to any one party (Refer to the UGC).
- 1.1.16 For the term “Weather Day” – refer to Attachment “C” to the Owner’s Special Conditions.
- 1.1.17 The term “Work Day,” as used throughout the contract documents, shall refer to a day in which a minimum of 8 hours of work is planned, excluding weekends and holidays.

1.2. PURPOSE

- 1.2.1 **Time is an essential part of this contract. Therefore, the timely and successful completion of the Work requires careful planning and scheduling of all activities inherent in the completion of the Project.**
- 1.2.2 **Acceptance of the Construction Schedule, or any subsequent update thereof by the Owner, is for format and extent of detail of the Construction Schedule only. Such “Acceptance” does not indicate approval of the Contractor’s means or methods, or of any change to the contract terms including without limitation any required contract Milestones.**

- 1.2.3 The Construction Schedule shall be developed to allow for a minimum amount of Total Float for the Project during Pre-Construction and/or Construction Services, and shall be formatted in a manner that facilitates reporting of progress and trends, identification of risks and opportunities, projecting upcoming activities, and forecasting of project milestones.
- 1.2.4 The Owner must be able to reasonably rely on the Contractor's Construction Schedule for projected activity dates in order to make accurate commitments to design professionals, contractors, vendors, user group(s), campus administration and other parties as necessary.
- 1.2.5 This specification applies to all project delivery methods regardless of contract type. For Projects with multi-phase delivery, the requirements within shall pertain to each.
- 1.2.6 All references to Pre-Construction Services in this specification shall apply to all contract types other than Competitive Sealed Proposals (CSP).

1.3. RELATED DOCUMENTS

- 1.3.1. In addition to specific references indicated herein, the Contractor's attention is specifically directed to, but not limited to, the following Sections and Documents, which include additional administrative requirements.
 - 1.3.1.1. Uniform General Conditions for University of Texas System Building Construction Contracts (UGC)
 - 1.3.1.2. Owner's Special Conditions
 - 1.3.1.3. Section 01 31 00 - Project Administration
 - 1.3.1.4. Section 01 35 23 - Project Safety Requirements
 - 1.3.1.5. Section 01 45 00 - Project Quality Control
 - 1.3.1.6. Section 01 77 00 - Project Closeout Procedures
 - 1.3.1.7. Section 01 91 00 – Project Commissioning

1.4. CONTRACTOR RESPONSIBILITY

- 1.4.1. The Contractor is responsible for planning, management, coordination, and scheduling of all activities from a Notice to Proceed for Construction to Final Completion of the Project within the time allotted by the Agreement.
- 1.4.2. The Contractor is responsible for keeping the Owner and the Project Team fully informed of schedule status and upcoming activities throughout the Project via the Construction Schedule.

- 1.4.3. The Contractor is solely responsible for scheduling and status of all activities related to Pre-Construction, procurement of materials and subcontractors, construction, testing, inspection, commissioning, and Project turn-over to the Owner.
- 1.4.4. The Contractor shall provide adequate, reasonable, and detailed project planning throughout all aspects of its work to ensure completion of all activities within the Contract Time.
- 1.4.5. The Contractor's Pre-Construction and Construction project management personnel shall actively participate in the planning and development of the Construction Schedule and shall be prepared to review such development and progress with the Owner, Architect, and any other members of the Project Team so that the planned sequences and procedures are clearly understood by all parties.
- 1.4.6. The Contractor shall plan for appropriate activity durations to allow for thorough review, procurement, submittal, installation, inspection, testing, and commissioning, of all work and/or systems in order to confirm contract compliance, including work relying on Owner participation or coordination.
- 1.4.7. The Contractor shall include in the schedule any activities required by local, municipal, county, state, or federal authorities having jurisdiction over the project including, but not limited to, durations for permits, easements, and utility connections.

PART 2 – PRODUCTS

2.1 QUALIFICATIONS OF THE CONTRACTOR'S SCHEDULER

- 2.1.1 The Contractor shall assign a Scheduler who shall be responsible for the Construction Schedule throughout Pre-Construction and Construction Services.
- 2.1.2 The Contractor's Scheduler shall have at least an undergraduate degree in a construction related field, and continuous experience on similar size and type of project(s) within the past five (5) years including at least two (2) years with the current specified scheduling software.
- 2.1.3 In lieu of a degree, the Contractor's Scheduler may have at least five (5) years continuous experience on similar size and type of project(s) with the current specified scheduling software.
- 2.1.4 The Contractor's Scheduler shall be an integral part of the Project Team during Pre-Construction Services and on-site full time for Construction Services until at least Substantial Completion of the work. The Contractor's Scheduler may have additional responsibilities such as Senior Project Manager, Project Manager, Superintendent, Assistant Project Manager, Assistant Superintendent, or Project Engineer.

2.1.5 If the Contractor's Scheduler is outsourced, the Contractor shall assign an on-site contact for all Construction Schedule related issues.

2.1.6 All Contractor personnel involved in the preparation, updating and reporting of the Construction Schedule shall possess adequate construction scheduling knowledge related to the Project, Critical Path Method (CPM) scheduling, as well as a general understanding of the specified software.

2.2 REQUIRED SCHEDULING SOFTWARE

2.2.1 The Construction Schedule shall be developed and maintained by the Contractor's Scheduler using Microsoft Project software.

2.3 NAMING THE CONSTRUCTION SCHEDULE

2.3.1 The Contractor's Scheduler shall title the Project Baseline Schedule using the name of the project and date schedule was issued or updated once accepted by the Owner's Designated Representative.

2.3.2 Subsequent updates to the Construction Schedule shall be titled using the name of the project and date equals the schedule update's Data Date – January 25th, 2019.

2.3.3 If at any time the Baseline Schedule is "reset" (with approval by the Owner), the title shall be titled the name of the project and R# (i.e., the first revised baseline would be R1) once accepted by the Owner's Designated Representative.

2.4 CONSTRUCTION SCHEDULE DEVELOPMENT REQUIREMENTS

2.4.1 The Construction Schedule calendar shall be based on a calendar days.

2.4.1.1 The term "Holidays", as used throughout the contract documents, shall refer to New Year's Day, Memorial Day, July 4th, Labor Day, Thanksgiving (including the Friday after), Christmas Eve, Christmas Day, and New Year's Eve.

2.4.1.2 The Contractor may plan to work weekends and holidays, but the Construction Schedule shall be based on completing all work during normal work days and hours.

2.4.1.3 The Contractor shall include in the Construction Schedule any other non-work periods such as campus special events, ceremonies, and final exams referenced in the Owner's Special Conditions or as directed by the ODR.

2.4.2 The Construction Schedule shall include a Work Breakdown Structure (WBS) organized by project phase, stage, location, building, floor, area, elevation, system, etc.

<u>Example WBS Organization</u>	
FP	Facilities Programming
SD	Schematic Design
DD	Design Development
CD	Construction Documents
TH	THECB Submittal
GM	Guaranteed Maximum Price

<u>Example WBS Organization</u>	
SP	Subcontractor Bidding / Procurement
SU	Submittals
FD	Fabricate and Delivery
C	Construction
PC	Project Close-Out
CX	Commissioning Activities

2.4.3 The Construction Schedule shall assign “Responsibility Codes” (i.e., create a responsibilities directory) for every Contractor, subcontractor, supplier, fabricator, installer, design consultant, Owner, and any other party responsible for the accomplishment of an activity using the following Responsibility Codes as applicable:

<u>Responsibility Code & Description</u>	
Arch	Architect / Engineer
AV	A/V Equipment
Blind	Blinds, Shades, Window Coverings
Carp	Carpet
Casf	Casework Fabricator
Casi	Casework Installer
Cocw	Concrete Formwork
Conf	Concrete Finishing
Ctil	Ceiling / Acoustical Tile
Door	Doors & Frames
Dryw	Drywall / Light Gauge Stud Installer
Elec	Electrical
Elev	Elevator
Falm	Fire Alarm Systems
Fire	Fire Protection Systems
Ftil	Floor Tile
Furn	Furnishings
Glas	Glass / Glazing
Hard	Hardware
Hvac	HVAC
Insu	Insulator
Irri	Irrigation
Labc	Laboratory Casework Fabricator
Labi	Laboratory Casework Installer
Land	Landscaping
Lbeq	Laboratory Equipment
Masn	Masonry
Offe	Owner’s Furnishings
Omat	Owner’s Material Testing Firm

<u>Responsibility Code & Description</u>	
OPCI	Owner Provided – Contractor Installed Equipment
OPOI	Owner Provided – Owner Installed Equipment
Otab	Owner’s Test & Balance Firm
Ownr	Owner
Pntr	Paint & Wall Coverings
Pier	Piers / Piles / Caissons
Plas	Plaster / EIFS
Plum	Plumber
Rebf	Reinforcing Steel Fabricator
Rebi	Reinforcing Steel Installer
Roof	Roofing
Seal	Sealants
Sign	Signs
Site	Sitework
Stee	Steel Erector
Stef	Steel Fabricator
Mstf	Miscellaneous Steel Fabricator
Msti	Miscellaneous Steel Installer
Site	Site Utilities
Tele	Telephone / Communication Systems
Terz	Terrazzo
Toia	Toilet Accessories
Toip	Toilet Partitions
Watp	Waterproofing / Dampproofing
Wodf	Wood Flooring
Wods	Wood Framer & Supplier

2.4.3.1 The Contractor’s Scheduler shall use additional Responsibility Codes as applicable.

2.4.3.2 If a subcontractor(s) has been procured, the Contractor may substitute the associated Responsibility Code above with a different code identifying the name of the subcontractor.

- 2.4.3.3 The Contractor’s Scheduler may use additional Secondary Activity and Responsibility Codes as necessary for monitoring, statusing, and reporting the Construction Schedule.
- 2.4.4 The Contractor’s Scheduler shall assign a unique “Activity Identification” (Activity ID) and “Activity Description” to every activity, and they shall be meaningful, easily understood by the Project Team, similar to like activities at differing locations, and as shown on the Contractor’s Schedule of Values.
- 2.4.4.1 Activity Descriptions shall start with a verb to indicate what is to be done and end with a location (Example: Install Metal Studs - 3rd floor Bldg B).
- 2.4.4.2 A “Milestone” Activity shall refer to any major event or phase, or any other important point in the Project, including the following Activities as applicable:

<u>Milestone Activity ID & Description</u>	<u>Milestone Activity ID & Description</u>
PC1 NTP for Pre-Construction Services	C4 Start Demolition
SD1 Start Schematic Design	C5 Complete Primary Foundations
SD2 Submit for Owner Review	C6 Structural Top-Out
SD3 Joint Review for Owner Comments	C7 Start New Framing
SD4 Approve Schematic Design	C8 Start MEP Rough-In
BR1 FPCC & BOR Submission	C9 Building Dry-In
BR2 FPCC & BOR Approval	C10 Start Mockups
DD1 Start Design Development	C11 Start Finishes
DD2 Submit for Owner Review	C12 Permanent Power
DD3 Joint Review for Owner Comments	C13 Energize Equipment
DD4 Approve Design Development	C14 Conditioned Air
TH1 Construction Application Submittal	CX1 Commissioning Kickoff Meeting
TH2 Construction Application Approval	CX2 Building Automation System Submittal Approval
GM1 Submit GMP	CX3 Control Sequence of Operation Coordination Meeting
GM2 Approve GMP	CX4 Ethernet Connectivity
CD1 Start Construction Documents	CX5 Building Envelope Testing & Verification Documents
CD2 Submit for Owner Review	CX6 Major HVAC System Startup
CD3 Joint Review for Owner Comments	CX7 System Specific TAB Activities
CD4 Approve Construction Documents	CX8 Integrated System Tests
C1 NTP for Construction Services	CX9 Entire Facility Integration Tests
C2 Partnering/Pre-construction Conference	C15 Start Above Ceiling Inspections
C3 Establish Site Controls /Mobilize	C16 Start Pre-Final Inspections
	C17 Start Final Inspections
	C18 Substantial Completion

- 2.4.4.3 A “Detailed” Activity shall refer to a singular work event in the Project.
 - 2.4.4.4 A “Summary” Activity shall refer to a grouping (or a summary) of Milestone and/or Detailed activities in the Construction Schedule.
 - 2.4.5 The Construction Schedule shall include all construction procurement “Administration” activities associated with the submittal, fabrication and delivery of work as applicable. The schedule shall, at a minimum, include procurement activities for materials and equipment that may have significant fabrication and delivery lead times. This does not preclude the requirement for the Contractor to maintain a separate detailed submittal tracking log.
 - 2.4.6 A minimum of 15 calendar days total shall be allotted to the A/E and ODR for each submittal review unless otherwise approved by the ODR.
 - 2.4.7 The Construction Schedule shall include all detailed commissioning related activities as listed in Part 3 of Specification Section 01 91 00, General Commissioning Requirements, as applicable.
 - 2.4.8 The Construction Schedule shall include activities for any anticipated local, municipal, county, state, or federal requirements for utilities connections, easements, vacations, upgrades, replacements, extensions, and/or permits.
- 2.5 PROJECT SCHEDULING REQUIREMENTS
- 2.5.1 The Contractor’s Scheduler shall use the Critical Path Method (CPM) as the scheduling technique in the development of the Construction Schedule.
 - 2.5.1.1 “Retained Logic” is the required scheduling mode when scheduling progressed activities. The “Retained Logic” scheduling mode requires that the remaining duration of a progressed activity not be scheduled until all of its predecessors are completed. The Contractor’s Scheduler shall not use the “Progress Override” mode option in developing or updating the Construction Schedule.
 - 2.5.1.2 Appropriate activity predecessor and successor logic relationships must be in place. With the exception of the first and last activity in the schedule, every activity shall have at least one predecessor and one successor activity.
 - 2.5.1.3 Other than the first and last activity, the construction schedule shall be free of any mandatory date constraints unless approved by the ODR.
 - 2.5.1.4 The use of a “Must Finish By” constraint on the overall Project is required. The “Must Finish By” constraint is placed at the project level and not at the activity level.
 - 2.5.2 Estimated construction Activity Durations shall be stated in work days (i.e. Monday through Friday).

2.5.2.1 The maximum duration for any Detailed Activity shall be thirty (30) work days.

2.5.2.2 The minimum durations for any Owner Inspection activity (i.e. concealed space, above ceiling, substantial and final completion) shall be at least three (3) work days per inspection and re-inspection, per work area.

2.5.3 Estimated remaining Activity Durations shall be stated in work days, as of the Data Date of every Construction Schedule update.

2.5.4 Administrative activities, including material and equipment procurement lead times, may have durations longer than thirty (30) work days.

2.6 CONSTRUCTION SCHEDULE ANALYSIS REQUIREMENTS

2.6.1 The Contractor's Scheduler shall use the Critical Path Method (CPM) technique to determine the overall Project duration through the analysis of the durations of each of the activities, their schedule dependencies, and their resultant float.

2.6.2 In accordance with the UGC, the Project Schedule shall include at least **10%** Total Float from the effective date of Notice to Proceed for Construction Services to the Substantial Completion Date.

2.6.2.1 If the Project warrants the planning of work to occur on Saturday and/or Sunday, the respective days shall be used in the calculation of the Total Float requirements. (i.e., Normal 5 day work week x 10% = 0.5 days of Total Float required, while an Accelerated 6 day work week x 10% = 0.6 days of Total Float required.)

2.6.2.2 The 10% minimum Total Float requirement for construction services shall be in addition to the anticipated weather days specified in Attachment "C" in the Owner's Special Conditions.

2.6.2.3 The 10% minimum Total Float requirement for construction services shall not be represented as a single activity, but rather the resultant of the relationship between the early and late finish dates or early and late start dates of each Activity on the schedule's Longest Path.

2.6.2.4 Per the Uniform General Conditions (UGC), float time contained in the CPM schedule is not for the exclusive benefit of the Contractor or the Owner, but belongs to the Project and may be consumed by either party as needed on a first-used basis. The use of project Total Float shall be documented in the "Executive Summary Report" (see Attachment A) and agreed upon by the Project Team.

2.7 COORDINATION WITH OTHER DOCUMENTS AND WORK

2.7.1 The Construction Schedule shall be coordinated with the Contractor's Submittal Schedule and Schedule of Values, as required by the UGC and Specification Section

01 31 00. (i.e., the Work Breakdown Structure shall be arranged, numbered, and described consistently across the various documents.)

- 2.7.2 Cost and/or resource loading of the Construction Schedule is allowed. If the Contractor elects to cost-load the Construction Schedule, the Contractor shall provide a separate Schedule of Values in the format required by Specification Section 01 31 00 - Project Administration.

PART 3 – EXECUTION

3.1 PLANNING AND SCHEDULING WORKSHOP

- 3.1.1 Within fifteen (15) calendar days after a Notice to Proceed, the Contractor shall conduct a Planning and Scheduling Workshop with at least the Contractor’s Scheduler, Project Manager, Superintendent, the Owner, the Architect, User representatives, and any available Subcontractors prior to submitting the Construction Schedule to the Owner.
- 3.1.1.1 The Contractor’s Scheduler shall schedule and coordinate the workshop with the Owner’s Designated Representative at least ten (10) calendar days prior to the Planning and Scheduling Workshop.
- 3.1.1.2 The Contractor’s Scheduler shall submit a complete draft Construction Schedule to the Owner’s Designated Representative at least five (5) calendar days prior to the Planning and Scheduling Workshop.
- 3.1.1.3 The Contractor’s Scheduler shall review the draft Construction Schedule with the Project Team, including a verbal description of the logic and sequencing of activities, method for determining estimated activity durations and corresponding resources required, and any activities involving Owner participation and/or approval.
- 3.1.2 For CM and DB projects, at least two (2) Planning and Scheduling Workshops shall be scheduled; the first shall be within fifteen (15) calendar days after a Notice to Proceed Pre-Construction Services and the second at within fifteen (15) calendar days after a Notice to Proceed Construction Services for each “major” GMP executed.

The purpose of the pre-construction conference shall result in approval of the baseline for pre-construction.

- 3.1.3 Attendance at the Planning and Scheduling Workshop and acceptance of the Baseline Construction Schedule is a condition precedent to the Contractor submitting initial and any subsequent progress payments.

3.2 CONSTRUCTION PHASE BASELINE SCHEDULE SUBMITTAL

- 3.2.1 The Baseline Construction Schedule shall be submitted to the Owner with the required Total Float and a current Data Date (less than or equal to five (5) work days) as prescribed by the UGC (or as accepted by the Owner in the Project Planning and Scheduling Workshop).
- 3.2.1.1 The Contractor is responsible for submitting the Baseline Construction Schedule within the prescribed time regardless of when Subcontractors are procured and brought on to the project.
- 3.2.1.2 For contract types other than Competitively Sealed Proposals (CSP), the Construction Schedule may include Milestone and/or Summary Activities for the remaining work that has not been approved in an executed GMP Proposal for Construction Services.
- 3.2.1.3 Once the “full” scope of the Project has been approved (i.e., the last Stage GMP Change Order has been executed), the Contractor’s Scheduler shall coordinate with the Owner’s Designated Representative to “reset” the Baseline Construction Schedule.
- 3.2.1.4 The minimum 10% Total Float (or as amended by the Owner’s Special Conditions) shall remain in the Construction Schedule from the Notice to Proceed for Construction Services until the Baseline Schedule is accepted by the Owner, regardless of any delays incurred by the Project without affecting the Substantial Completion Date.
- 3.2.1.5 No activity shall have a Total Float amount greater than the minimum Total Float identified by the Longest Path plus forty-five (45) days.
- 3.2.1.6 The Owner reserves the right to withhold any and all payments related to the Construction Schedule and/or General Conditions if a Baseline Construction Schedule is not submitted, or is not acceptable to the Owner. If the parties cannot agree on a Baseline Schedule, the Owner may deduct any monies related to Project Scheduling, and/or costs associated with schedule recovery.
- 3.2.1.7 If the Baseline Construction Schedule has not been accepted by the Owner, each successive baseline submittal shall be updated to status the current progress of the work until it is accepted by the Owner.
- 3.2.1.8 A Baseline Construction Schedule that does not have at least the minimum amount of Total Float at submission shall result in the Contractor forfeiting all claims to Construction Schedule extensions and/or delays as a result of contract changes and/or excusable delays as described in the UGC.

3.2.2 The Contractor's Scheduler shall submit electronically two (2) electronic Microsoft Project backup files, two (2) electronic Adobe PDF files, and two (2) paper copies of the following Baseline Construction Schedule reports to the Owner's Designated Representative:

3.2.2.1 Graphic Time-Scaled Report (Gantt Chart): A graphic time-scaled view including all activities, Percent Complete, Start and Finish dates, estimated durations, and Total Float. Organize activities by Work Breakdown Structure (WBS) and sort by activity Start Date.

3.2.2.2 Longest Path Time-Scaled Report (Gantt Chart): A graphic time-scaled view of Detailed Activities on the Longest Path from the Data Date to Contract Completion. Organize activities by Work Breakdown Structure (WBS) and sort by activity Start Date.

3.2.2.3 Owner Activity Time-Scaled Report (Gantt Chart): A graphic time-scaled view of Detailed Owner Activities from the Data Date to Contract Substantial Completion. Organize activities by Work Breakdown Structure (WBS) and sort by activity Start Date.

3.2.2.4 Milestone Activity Report: A listing of every Milestone Activity organized by Work Breakdown Structure (WBS) and sorted by Milestone Start Date.

3.2.2.5 Detailed Activity Report: A listing of every Detailed Activity sorted by activity Start Date.

3.2.2.6 CPM Logic Report: A listing of every detailed activity identifying every Predecessor and Successor activity sorted by Activity ID.

3.2.3 Once the initial Construction Schedule has been accepted, it shall be referred to as the Baseline Construction Schedule, and shall be used for all future Construction Schedule updates and reports as "Project Baseline."

3.2.3.1 For all project delivery methods other than Competitively Sealed Proposals (CSP), the Construction Schedule may include Milestone and Summary activities until thirty (30) days prior to the submittal of a Guaranteed Maximum Price (GMP) Proposal for Construction Services, but shall include Detailed Activities for at least the first ninety (90) days of Construction Services when submitted with the GMP Proposal.

3.3 UPDATING THE CONSTRUCTION SCHEDULE

3.3.1 Once the Baseline Construction Schedule has been accepted, the Contractor's Scheduler shall update the Construction Schedule for Pre-Construction and Construction Services at least once a month and submit reports at least five (5) work days prior to any application for payment.

- 3.3.1.1 Construction Schedule updates shall be based on actual work progress, current logic and remaining durations.
- 3.3.1.2 The Contractor shall maintain throughout the duration of construction a Total Float value on the Longest Path of not less than 10% of the remaining schedule duration unless approved by the ODR. Use of Total Float shall be documented in the end-of-month schedule update and associated “Executive Summary Report” (see Attachment A) and agreed upon by the Project Team.
- 3.3.1.3 The Contractor shall transmit to the Owner and ODR an electronic copy of the Final As-built schedule (PDF and Primavera XER Backup files) at Substantial Completion.

3.4 CONSTRUCTION SCHEDULE REPORTS

- 3.4.1 The Data Date for all Construction Schedule Update Reports shall be current within five (5) work days of submission to the Owner’s Designated Representative.
- 3.4.2 The Contractor’s Scheduler shall submit two (2) electronic Primavera P6 backup files (.xer), two (2) electronic Adobe PDF files, and two (2) paper copies of the following construction schedule reports to the Owner’s Designated Representative:
 - 3.4.2.1 Executive Summary Report: A narrative report developed, monitored and updated by the Contractor’s Scheduler for each schedule submission that includes:
 - 3.4.2.1.1 A Total Float Usage Log that identifies the number of days lost / gained each month, including an explanation of each event.
 - 3.4.2.1.2 An Adverse Weather Day Summary comparing the anticipated weather days to the actual weather days.
 - 3.4.2.1.3 A description of the progress of the Detailed Activities on the Longest Path Bar Chart
 - 3.4.2.1.4 A description of current and anticipated problems and/or delaying factors and their possible impact
 - 3.4.2.1.5 An explanation of any and all changes to the CPM logic, including constraints, durations, and relationships

Refer to Attachment A to this specification for an example Executive Summary Report.

- 3.4.2.2 Graphic Time-Scaled Report (Gantt Chart): A graphic time-scaled view including all activities, Percent Complete, Start and Finish dates, estimated durations, and Total Float. Organize activities by Work Breakdown Structure

(WBS) and sort by activity Start Date. Include a comparison to the accepted Baseline Construction Schedule.

- 3.4.2.3 Longest Path Bar Chart: A graphic time-scaled view of on-going and future Detailed Activities on the Longest Path from the Data Date to the contract Substantial Completion Date.
Level 1 Filter is “Longest Path = Yes”
Level 2 Filter is “% Complete < 100”
- 3.4.2.4 Owner Activity Bar Chart: A graphic time-scaled view of Detailed Owner Activities from the Data Date to the Owner’s established Substantial Completion Date.
- 3.4.2.5 Three-Month Rolling Bar Chart: A graphic time-scaled view of all Detailed Activities completed, on-going or starting one (1) month earlier and two (2) months after the Data Date.

Level 1 Filter is “Actual Finish WR DD – 20”
Level 1 Filter is “Actual Finish WR DD + 0”
Level 1 Filter is “Early Start WR DD + 0”
Level 1 Filter is “Early Start WR DD + 40”
Level 2 Filter is “Activity % Complete < 100”
- 3.4.2.6 The Owner at any time may request additional Construction Schedule reports.

3.5 FORMATTING CONSTRUCTION SCHEDULE REPORTS

- 3.5.1 Printed schedule reports shall be on standard 8 ½” x 11” paper unless otherwise directed by the Owner’s Designated Representative.
- 3.5.2 Electronic copies of the Construction Schedule and associated reports shall be submitted to the ODR via e-mail or other approved method with the subject/contents clearly titled (example: 102-081 10/25/18 Schedule Update).

All electronic Construction Schedule submittals shall be in Microsoft Project and Adobe PDF format.

- 3.5.3 Each report shall include a footer with the following information:
- 3.5.3.1 A “Date Block” indicating the start date, finish date, Data Date, run date, and “Must Finish By” date
- 3.5.3.2 A “Title Block” indicating the Owner’s Project Number and Title, and the Name of the Report (i.e., Layout)
- 3.5.4 Refer to “Attachment B” to this specification for an example Gantt chart report layout.

3.6 CONSTRUCTION SCHEDULE SLIPPAGE

3.6.1 If the percent Total Float used by the project exceeds the percent of construction duration spent, or the Total Float is negative, the Contractor's schedule update shall include a Recovery Plan to make immediate revisions to the work force, work-hours, shifts, material deliveries or any other aspects of the work. The Recovery Plan shall be for review and acceptance by the Owner's Designated Representative (ODR) as part of the following schedule update (i.e., If the project has 50% of the original construction duration remaining, but has only 25% of the original Total Float remaining, the Contractor shall submit a Recovery Plan.)

3.6.2 The Contractor shall submit the Recovery Plan to the Owner's Designated Representative (ODR) as required in the UGC, clearly describing all the changes in schedule or work enacted and/or planned in order to ensure completion by the contract Substantial Completion date. The Recovery Plan shall reference the Work Progress Schedule Activity IDs included in the plan.

The Owner shall have the right to review and comment on any Recovery Plan activities that include Owner participation, or affect any Owner consultants or outside contractors.

3.6.3 Once the Owner's Designated Representative (ODR) accepts the Recovery Plan, the proposed revision shall be incorporated into the Work Progress Schedule. While the schedule is in recovery mode, the Work Progress Schedule shall be updated and submitted to the ODR on a weekly interval until the ODR determines that a full recovery of the schedule has been made.

3.7 CONSTRUCTION SCHEDULE CHANGES

3.7.1 If the Owner or Architect issues a Change Order Proposal, the Contractor shall submit a proposed fragnet revision for all proposed contract changes that affect the Substantial Completion Date or remaining Total Float with the Change Order Proposal pricing.

Proposed fragnet revisions shall be accompanied by a narrative listing of the affected activities including a statement of the expected overall impact of the change proposed.

3.8 EXCUSABLE DELAYS AND TIME EXTENSIONS

3.8.1 Excusable delays shall be administered per the UGC.

3.8.2 If an excusable delay extends the Contract Substantial Completion Date, the Owner's Designated Representative may extend the contract time by the number of excusable calendar days lost on the Construction Schedule, or take other actions as appropriate under terms of the Agreement.

Change Order Proposal pricing that does not impact the Substantial Completion Date or does not include a proposed fragnet revision prior to approval by the Owner's Designated Representative, shall not be due a time extension.



The University of Texas
Health Science Center at Houston

- 3.8.3 Once the Owner's Designated Representative accepts a time extension, and authorizes the Contractor to proceed with the contract change, the proposed revision shall be incorporated into the Construction Schedule.

END OF SECTION 01 32 00

ATTACHMENT A – EXAMPLE EXECUTIVE SUMMARY REPORT

The University of Texas at Austin
Example Project
OFPC Job No. XXX-XXX

Executive Summary Report for MAR 2006
Contractor Name
As of March 25, 2006

Schedule Overview

a.	Date of Notice to Proceed	5/10/2005	
b.	Current Contractual Substantial Completion Date *	11/15/2006	
c.	Duration in Calendar Days	554	(b-a)
d.	Duration in Work Days	396	(c*5/7)
e.	10% Minimum Total Float in Baseline *	40	(d*10%)

f.	CPM Update Date (Data Date)	3/25/2006	
g.	Calendar Days Consumed	319	(f-a)
h.	Work Days Consumed	228	(g*5/7)
i.	% Time Consumed (From NTP through CPM Data Date)	58%	(h/d)
k.	% Time Remaining (From CPM Data Date to Current S/C Date)	42%	(1-i)
l.	10% Total Float Expected for Remaining Project Duration	17	(k*e)
m.	Actual days Total Float Remaining on CPM's Longest Path	21	
n.	Days Ahead (+)/Behind(-) based on CPM Total Float	+4	(m-l)

- Executed Change Orders involving time will need to be accounted for in rows (b) and (e).

Project Duration and Total Float

The project Total Float increased to 21 days for this update (3/25/06). The substantial completion date remains November 15, 2006. Following issues caused changes in project Total Float.

1. **OCT 2005 (Revised Baseline Schedule)**
 - a. Site Permit Delay to Start Work – Activity ID 1010 - 11 days
 - b. Biggs's Heavy Duty Plumbing – Activity ID 1544 - 6 days
 - c. Relocation for Overhead Utilities – Activity ID 1228 - 10 days
2. **NOV 2005 (Monthly Update)**
 - a. Relocation for Overhead Utilities – Activity ID 3334 - 8 days
3. **Recovery Schedule (12/25/2005)**
 - a. Recovery Plan – See Attached Plan + 24 days
4. **JAN 2006 (Monthly Update)**
 - a. Weather Impact (11 Jan 06) – See Weather Day Log Attached - 1 day
 - b. Approval for the Windows – Activity ID 4321 - 11 days
5. **FEB 2006 (Monthly Update)**
 - a. Windows Fab & Delivery Expedition – Activity ID 1774 + 4 days
6. **MAR 2006 (Monthly Update)**
 - a. No changes this month 0 days

ATTACHMENT A – EXAMPLE EXECUTIVE SUMMARY REPORT (CONTINUED)
Weather Day Summary (Owner’s Special Conditions Attachment C)

	2005 MAY	2005 JUN	2005 JUL	2005 AUG	2005 SEP	2005 OCT	2005 NOV	2005 DEC	2006 JAN	2006 FEB	2006 MAR	2006 APR	2006 MAY	2006 JUN	2006 JUL	2006 AUG	2006 SEP	2006 OCT	2006 NOV
Anticipated	4	4	1	1	2	3	2	4	6	4	4	3	4	4	1	1	2	3	2
Actual	2	3	2	3	0	1	3	0	7	3	6								
Over			1	2			1		1		2								

Longest Path Activities Completed or In Progress This Period

1. Main Building (Phase 2)
 - ◆ Activity 4332 - M/S frame & exterior gypsum - Completed
 - ◆ Activity 4505 - Set FCU’s and carriers – In Progress
2. Utility/Tunnel Work
 - ◆ Activity 5900 – Tunnel Overhead MEP - Completed.
 - ◆ Activity 5910 - SS Line MH #6 to ML #8 - In Progress.

Current and Anticipated Problem, Delays and Impact



1. The slab deflections are greater than the engineer’s model. If a load test is required, this could have an impact on our schedule. After the meeting on February 1, 2006, Contractor was unofficially informed that a load test was not going to be performed. However, Contractor has not received the official report indicating this issue is resolved.
2. The issuance of construction documents for interior finishes dated 2/22/06 were received on February 24, 2006. Contractor is currently reviewing these drawings and will forward on any schedule impacts created by these drawings.
3. The brick veneer was delivered and it did not match the mockup. Our subcontractor is currently working with their suppliers to have the brick remade. Contractor continues to track this issue and will forward any schedule impacts created by this issue.

Added, Deleted and Revised activities and Logic

- New activities named “1st, 2nd and 3rd Owner-EXT. Finish Inspection” were added on schedule instead of the Owner-EXT. Finish Inspections of each side to reflect actual construction sequence.
- Added new activity for “Insulate Duct Work” and tied to “Frame hard ceiling” as a predecessor with FS relationship.
- Revised the activity description “Install/Insulate process pipe” to “Install process pipe”.
- Set Plumbing Fixtures is tied to 2nd Side Drywall with FS relationship as a successor to reflect actual sequence.
- Deleted the FS relationship between Install Brick Veneer, Cast Stone (P1LE04001) and Install Deck & Felt @ Roof (P1LR05003) to reflect actual sequence.
- Deleted the FS relationship between Install Brick Veneer, Cast Stone (P1LE04002) and Install Wood Soffits, Gutter System (P1LE07008) to reflect actual sequence.
- Deleted the FS relationship between Owner-Roof Inspection (P1LR077500) and Install Wood Soffits, Gutter System (P1LE07009) to reflect actual sequence.
- Install Process Pipe @ Level 6 Wall is tied to Insulate Process Pipe @ Level 1 with FS as a predecessor to reflect actual construction sequence.

ATTACHMENT B – EXAMPLE GANTT CHART LAYOUT

PROJECT# - PROJECT NAME HERE		COMPANY NAME HERE					15-Nov-13 11:35											
Activity ID	Activity Name	OD	Activity % Complete	Start	Finish	TF	Late Finish	2013				2014						
								Sep	Oct	Nov	Dec	Jan	Feb	Mar	Apr	May	Jun	
01 32 00 Sample Gantt Chart Layout		470		16-Sep-13 A	28-Jul-15	46	01-Oct-15	←→										
PRECONSTRUCTION / GMP:		160		16-Sep-13 A	05-May-14	141	21-Nov-14	←→ 05-May-14										
Design Development		123		16-Sep-13 A	14-Mar-14	0	13-Mar-14	←→ 14-Mar-14, Design Deve										
DD1000	Issue 100% DDs for preparing GMP	0	100%	16-Sep-13 A				◆ Issue 100% DDs for preparing GMP										
DD1060	Joint Review Workshop - 100% DDs	3	100%	01-Oct-13 A	03-Oct-13 A		10-Feb-14	▮ Joint Review Workshop - 100% DDs										
DD1010	Issue 50% CDs	0	100%	30-Oct-13 A				◆ Issue 50% CDs										
DD1050	Joint Review Workshop - 50% CDs	2	0%	12-Nov-13*	13-Nov-13	66	21-Feb-14	▮ Joint Review Workshop - 50% CDs										
DD1030	Issue 75% CDs	0	0%	06-Dec-13*		52		◆ Issue 75% CDs										
DD1070	Joint Review Workshop - 75% CDs	3	0%	16-Dec-13*	18-Dec-13	46	26-Feb-14	▮ Joint Review Workshop - 75% CDs										
DD1080	Issue 95% CDs Pkg.	0	0%	11-Feb-14*		12		◆ Issue 95% CDs Pkg.										
DD1090	Joint Review Workshop - 95% CDs	3	0%	25-Feb-14*	27-Feb-14	2	03-Mar-14	▮ Joint Review Workshop - 95% CDs										
DD2000	Approve Construction Documents	0	0%		11-Mar-14	2	13-Mar-14	◆ Approve Construction Documents										
DD3000	Issue Final Sealed CDs Set	0	0%		14-Mar-14*	0	13-Mar-14	◆ Issue Final Sealed CDs Set										
GMP Development		53		16-Sep-13 A	27-Nov-13	46	07-Feb-14	←→ 27-Nov-13, GMP Development										
GM010	Prepare GMP Estimate & Deliverables	35	100%	16-Sep-13 A	06-Nov-13 A		20-Jan-14	▮ Prepare GMP Estimate & Deliverables										
GM020	Prep & Submit Safety Plan for OFPC Review	10	100%	21-Oct-13 A	06-Nov-13 A		20-Jan-14	▮ Prep & Submit Safety Plan for OFPC Review										
GM1	Submit GMP package	0	100%		06-Nov-13 A		20-Jan-14	◆ Submit GMP package										
GM030	OFPC Review & Approve of GMP	15	0%	07-Nov-13	27-Nov-13	46	07-Feb-14	▮ OFPC Review & Approve of GMP										
GM2	Approve GMP / Issue NTP	0	0%		27-Nov-13	46	07-Feb-14	◆ Approve GMP / Issue NTP										
Subs Buy-Out / Procurement		107		02-Dec-13	05-May-14	141	21-Nov-14	←→ 05-May-14										

Start Date	10/25/13		Actual Work	Date	7-NOV-13	Revision	50% CD's	Checked	AUB	Approved	TGR
Finish Date	07/28/15		Remaining Work								
Must Finish Date	10/01/15		Critical Remaining Work								
Data Date	11/07/13	◆	Milestone								
		←→	Summary								



The University of Texas
Health Science Center at Houston

REVISION LOG

The following is provided for convenience to the Owner, Architect/Engineer and Contractor to track changes between annual document issuances and is not to be considered by any party to be contractual or 100% complete.

Date	Paragraph Revised
09/23/19	Original Document

SECTION 01 35 23 – PROJECT SAFETY REQUIREMENTS

PART 1 – GENERAL

1.1 OVERVIEW

The Owner's objective is an injury and incident-free project, with a focus on project safety that shall not be compromised to achieve any other business objective. The Contractor shall structure an effective and systematic safety management approach that emphasizes continuous safety process improvement.

The Owner has included in this specification numerous safety requirements that are noticeably more stringent than that of the Occupational Safety and Health Administration (OSHA). The reader will see text throughout this specification, matching the format of this paragraph, and is intended to call attention to the fact that the requirement being described is more stringent than that of OSHA. However, this does not relieve the reader from reading and understanding the entire Specification.

1.2 GENERAL REQUIREMENTS

The Owner recognizes that the Contractor and Subcontractors may have existing safety management programs with established safety policies, processes, procedures, and work practices. The Owner will support these where they prove to be as effective and meet the intent and purpose of this Section. Upon request by the Owner, the Contractor and/or Subcontractors (of any tier) shall promptly produce and provide copies of any required documents related to Project safety. Where opportunities for improvement are identified, the Contractor and Subcontractors of any tier shall work collaboratively with the Owner in making appropriate revisions to progress toward an injury and incident-free workplace.

1.3 DEFINITIONS

- 1.3.1 The term "Owner's Safety Representative" (OSR) as used throughout the Contract documents shall refer to any construction safety professional(s) who are acting on behalf of the Owner. This will include, but may not be limited to the ORM Safety Analyst, Campus Construction Safety Representative, and any Risk Control Consultants associated with the Owner.
- 1.3.2 The term "Project Safety Coordinator" (PSC) as used throughout the Contract documents shall refer to the Contractor's construction safety professional who is acting on behalf of the Contractor and who shall be responsible for safety training, inspections, incident investigations, record keeping, reporting, incident response, and claims management, and shall serve as the technical advisor to the Contractor's project staff for all safety issues.

- 1.3.3 The term “Project Safety Assistant(s)” (PSA) as used throughout the Contract documents shall refer to any Contractor’s construction safety professional who is acting on behalf of the Contractor and who shall perform safety related tasks as delegated by the PSC.
- 1.3.4 The term “Subcontractor’s Safety Representative” (SSR) as used throughout the Contract documents shall refer to a person employed by the Subcontractor of any tier who is identified as the recognized safety representative and who possesses the proper credentials for the position. The SSR is understood to be the immediate supervisor unless identified and documented otherwise. All subcontractors of any tier shall provide at least one recognized SSR anytime the subcontractor is working on the project.
- 1.3.5 The term “qualified” as used throughout this Section shall match the definition within the OSHA construction safety standards (Title 29 CFR, Part 1926). *Qualified means one who, by possession of a recognized degree, certificate, or professional standing, or who by extensive knowledge, training, and experience, has successfully demonstrated the ability to resolve problems relating to the subject matter, the work, or the Project.*
- 1.3.6 The term “competent” as used throughout this Section shall match the definition within the OSHA construction safety standards (Title 29 CFR, Part 1926). *Competent person means one who is capable of identifying existing and predictable hazards in the surroundings or working conditions which are unsanitary, hazardous, or dangerous to employees, and who has authorization to take prompt corrective measures to eliminate them. In addition to the OSHA standard, this person must be trained and knowledgeable in the construction and/or operation of specific equipment or a specific work method and show proper documentation to support such training. Basic awareness training will not be acceptable for this position.*
- 1.3.7 The term “Construction Area” as used throughout this Section shall refer to the portion of the Owner’s property that is released to the Contractor’s care and control and is designated by the Contractor as the space where actual construction efforts will be undertaken to execute the Work.
- 1.3.8 The term “Administration Area” as used throughout this Section shall refer to the portion of the Owner’s property that is released to the Contractor’s care and control and is designated by the Contractor as the space where support efforts will be undertaken to provide administrative needs for the Work. If the Project has project office trailers within the confines of the Owner’s property, that space and the parking area around it may be designated as an Administration Area.
- 1.3.9 The term “worker” as used throughout this Section shall refer to any person who is assigned specifically to the Project, has successfully completed the Project safety orientation, and has been issued a project specific ID badge.
- 1.3.10 The term “visitor” as used throughout this Section shall refer to any person who is not assigned specifically to the Project. Visitors will not be issued a project specific ID badge

and shall not be allowed access to the “construction areas” unless they are escorted by a member of the Contractor’s project management staff or an Owner representative.

1.3.11 The term “Owner’s Designated Representative” (ODR) as used throughout the Contract documents shall refer to the individual(s) assigned by the Owner to act on its behalf, and to undertake certain activities as specifically outlined in the Contract. For the purposes of this specification section, the words “Owner” and “Owner’s Designated Representative” are interchangeable. The Owner’s Designated Representative is a representative of The University of Texas System Office of Facilities Planning and Construction or Project Manager for the Campus. The ODR is the only party authorized to direct changes to the scope, cost, or time of the contract.

1.4 PURPOSE

1.4.1 The Contractor shall bear overall responsibility for all aspects of safety for the Project.

1.4.2 The Contractor shall, at all times, provide adequate resources, equipment, training, and documentation to:

1.4.2.1 Comply with the requirements of this Section and all applicable Federal, State, and local statutes, standards, and regulations.

1.4.2.2 Provide a safe work environment at the Project.

1.4.2.3 Instill a culture of safe behavior in all supervisors and workers.

1.4.2.4 Ensure a universal understanding that safety and health issues take precedence over all other considerations at the Project.

1.4.3 In any circumstance where this Section differs from, or conflicts with any statutory requirement, the more stringent shall apply.

1.4.4 The ODR reserves the right to have any person removed from the Project for disregarding Project safety requirements. Removal of the Project Superintendent, Project Manager, any Supervisor, PSC, PSA or SSR may result in work stoppage that will remain in effect pending approval of a suitable replacement. The Contractor shall not be allowed any consideration for time or monetary compensation for said stoppage.

1.4.5 The ODR reserves the right to deduct from the Contract any safety related expenses that the Owner incurs as a result of the Contractor’s, or any Subcontractor’s, failure to comply with the requirements of this Section.

1.4.6 The ODR will deny requests for time extensions and/or monetary considerations whenever the Owner intercedes on behalf of safety compliance as a result of Contractor failure to act as required by Contract.

1.5 RELATED DOCUMENTS

In addition to specific references indicated herein, the Contractor's attention is also directed, but not limited, to the following publications and documents:

- 1.5.1 Current edition of Uniform General Conditions for The University of Texas System Building Construction Contracts (UGC);
- 1.5.2 Owner's Special Conditions;
- 1.5.3 Current edition of OSHA Safety Standards for the Construction Industry, CFR Title 29, Part 1926.

PART 2 – PRODUCT

2.1 PROJECT SAFETY COORDINATOR (PSC)

- 2.1.1 The Contractor must provide a qualified Project Safety Coordinator (PSC). The PSC is required from the commencement of construction until at least such time the Owner's Designated Representative (ODR) issues notice of Substantial Completion. ODR's written concurrence is needed prior to PSC removal. Overall recent career experience must include at least seven (7) years that have been dedicated solely to building construction safety with at least five (5) years of construction safety process management experience. Any candidate that has completed a four (4) year degree in a safety-related discipline must show at least three (3) years of actual field experience in safety to qualify for a PSC position. The PSC must have practical knowledge, working experience, and documented continuing education in fall protection, scaffolds, excavation, confined space, crane/equipment operations, electrical, incident investigation, and other such safety/health related training. Training of less than four (4) hours in duration per topic will not be considered acceptable for this requirement. Continuing education of noted training must be dated within five (5) years of the executed contract. OSHA 10/30-hour Construction Outreach or OSHA 510 certificates will not be acceptable for this training requirement. The PSC shall possess a certificate of completion for the OSHA 500 (Train the Trainer in Occupational Safety and Health for Construction Industry) or OSHA 502 (Update for the Construction Industry Outreach Trainer). The PSC must show evidence of specialized training for Emergency First Aid, Cardio Pulmonary Resuscitation (CPR), and Automatic External Defibrillator (AED) current to within two (2) years. Formal submittal of proof must be provided prior to acceptance and before any portion of the Work will be allowed to commence. The ODR reserves the right to determine acceptability of the submitted training. Any candidate proposed that does not meet these minimum qualifications will not be accepted.
- 2.1.2 For projects less than \$10M but greater than \$5M, a fully qualified Project Safety Assistant (PSA) as described in Section 2.2 (below) may act as the Project Safety Coordinator (PSC).

2.1.3 For projects \$5M or less, a PSA-IT (Field Experience Only) qualified individual as described in Section 2.2.1.1.2 (below) may act as the Project Safety Coordinator (PSC). This option allows the project Superintendent to perform both the duties of a Superintendent and PSC simultaneously.

2.2 PROJECT SAFETY ASSISTANT (PSA)

2.2.1 Project Safety Assistant(s) (PSA(s)) are also required. Number of and placement on the project is determined by the final contracted construction amount and average daily work force. Primary recent experience of any proposed PSA, must include at least five (5) years that have been dedicated solely to building construction safety. The PSA must have practical knowledge, working experience, and documented continuing education in fall protection, scaffolding, excavations, confined spaces, crane/equipment operations, electrical, incident investigation, and other such safety/health related training. Training of less than four (4) hours in duration per topic will not be considered acceptable for this requirement. Continuing education of noted training must be dated within five (5) years of the executed contract. An OSHA 10/30 Construction Outreach or OSHA 510 certification will not be acceptable for this training requirement. The PSA shall possess a certificate of completion for the OSHA 510 (Occupational Safety and Health Standards for the Construction Industry) or the OSHA 500 (Train the Trainer in Occupational Safety and Health for Construction Industry) or OSHA 502 (Update for the Construction Industry Outreach Trainer) in addition to the continuing education requirements previously noted. The certificate must be dated within five (5) years of the executed Contract. The PSA must show evidence of specialized training for Emergency First Aid, Cardio Pulmonary Resuscitation (CPR) and Automated External Defibrillator (AED) current to within two (2) years. Formal submittal of proof must be provided prior to acceptance. The ODR reserves the right to determine acceptability of the submitted training. Any candidate proposed that does not meet these minimum qualifications will not be accepted.

2.2.1.1 On projects over \$180M, the option of a PSA-IT (In-Training) may be considered for the required third PSA after the initial qualified PSAs are already active on the project. At no time shall a PSA-IT be used as a permanent substitute in place of a fully qualified PSA when required. Qualifications for individuals seeking PSA-IT classification shall comply with one of the following options:

2.2.1.1.1 Option I (College Degree in Safety) - Individuals that have obtained a Bachelor's or Master's Degree in Safety

1. The safety degree will count for four (4) years of the five (5) years currently required for a PSA position.
2. Successful achievement of a nationally recognized safety certification (CSP, CHST). The Owner reserves the right to determine years of credit based on the recognition of the certification, requirements to achieve certification, and continuing education to maintain certification. This option can be used to add additional experience.

3. Successful completion of one (1) year of dedicated safety work experience on the project.

Once this individual completes all the requirements indicated above for this option, the “In Training” will be dropped and the individual will be consistent with the current requirements of the UTS Safety Specification.

or

2.2.1.1.2 Option II (Field Experience Only) - Individuals that have a minimum of seven (7) years in the construction industry and two (2) years of safety responsibilities that are ancillary to their primary duties

1. The experience noted above will count for two (2) years of the five (5) years currently required for a PSA position.
2. Must have documented successful completion of initial training (minimum of eight (8) hours) each in cranes, electrical, fall protection, excavations and soil mechanics, scaffold, permit–required confined space, and incident investigation and
3. Documented successful completion of Supervisor Safety Training or equivalent from an OSHA Training Institute such as TEEK, UT Arlington, etc.

Once this individual completes all the requirements indicated above for this option, the experience level will be counted as four (4) years of dedicated safety experience. At successful completion of one (1) year of dedicated safety work, the “in Training” will be dropped and the individual will be consistent with the current requirements of the UTS Safety Specification.

2.3 PSC AND PSA - Verification of Qualifications

2.3.1 The qualifications and previous work experience of the proposed Project Safety Coordinator and Project Safety Assistant(s) shall be submitted with the RFP. Based on final Contractor selection for the project, additional information for the Project Safety Coordinator and Project Safety Assistant will be required prior to written acceptance for the position. Prior to Notice to Proceed for Construction Services, the Contractor must provide resumes for the proposed PSC and PSAs. Contractor selection for the project does not guarantee proposed PSC and/or PSA acceptance. Any PSC or PSA additions or changes after the original acceptance date(s) must be formally submitted for consideration to the ODR. In the case of the PSC, work shall not be allowed to commence prior to written acceptance by the ODR. In the case of the PSAs, each must be assigned to the project on or before the worker count reaches the numbers indicated in Sections 2.4 and 2.5. Any cost related to the Contractor’s failure to meet this requirement will not be reimbursed by the Owner and additional time extension of the Project schedule will not be allowed.

2.3.2 For two (2) years of military service that demonstrates construction safety experience or an Associate’s Degree in the field of safety, two (2) years of required experience will be credited for the requirements listed above. For four (4) years of military service that

demonstrates construction safety experience or a Bachelor's (Undergraduate) Degree in a safety related field, four (4) years of required experience will be credited for the requirements listed above. Military experience and/or degree will only receive credit once. A professional certification in a safety related field (CSP, OHST, CHST, etc.) may receive credit for up to four (4) years of experience in addition to the years noted above. The ODR reserves the right to determine year(s) of credit based on recognition of certification, requirements to receive certification, and continuing education requirements to maintain certification.

2.4 PSC AND PSA – Determining the Number of Required PSCs and PSAs

2.4.1 The total number of PSCs and PSAs for a Project will be determined by the anticipated total cost for construction services for the completed project using the values below:

2.4.1.1 For projects up to and including Ten Million Dollars (\$10,000,000), only the PSC shall be required.

2.4.1.2 For projects over Ten Million Dollars (\$10,000,000) and up to and including Thirty Million Dollars (\$30,000,000), the PSC and the initial PSA will be required. For projects over Thirty Million Dollars (\$30,000,000) and up to and including One Hundred Eighty Million Dollars (\$180,000,000), the PSC, initial PSA and an additional PSA will be required. For projects over One Hundred Eighty Million Dollars (\$180,000,000), the PSC, initial PSA, and two (2) additional PSAs will be required. Based on scope of work and/or anticipated hazard(s), additional PSA(s) may be required. Any additional PSA(s) beyond those noted above shall be determined and negotiated by the ODR prior to GMP.

2.5 PSC AND PSA -- Placement on the Project and Removal from the Project

2.5.1 The placement and removal of the PSC and any PSA for a Project will be determined by the daily population of persons, using the following:

2.5.1.1 One (1) PSC shall be provided by the Contractor and shall be assigned full time, have no duties other than safety, and be dedicated daily to the Project from the commencement of construction activities until at least Substantial Completion. The ODR's written concurrence is required prior to release.

2.5.1.2 The initial one (1) PSA shall be provided by the Contractor and shall be assigned full time, have no duties other than safety, and be dedicated daily to the Project at the time that the daily population reaches twenty-five (25) persons, and shall remain on the Project until at least Substantial Completion and the population decreases to less than 25 persons. The ODR's written concurrence is required prior to release.

2.5.1.3 The second PSA shall be provided by the Contractor and shall be assigned full time, have no duties other than safety, and be dedicated daily to the Project when the daily population at the Project rises to one hundred and fifty (150) persons. Additional

PSAs shall be provided by the Contractor and shall be assigned full time, have no duties other than safety, and be dedicated daily to the Project when the daily population increases by another increment of one hundred and fifty (150) persons. The additional PSAs shall remain on the Project until the daily population falls below the number that required them to be added. The ODR's written concurrence is required prior to release.

2.5.1.4 For Contracts that involve multiple Phases, Stages, and Change Orders, the value for construction services shall accumulate as additional packages of work are added to the overall contract. If there are significant gaps between the head count of the previous or current work and the additional work, the ODR will decide if the additional work shall impact only the demand for additional PSAs. The requirement for the PSC will remain as indicated in Section 2.5.1.1.

2.5.1.5 **During scheduled daily work, a full complement of safety persons must be on site in the numbers as required in Sections 2.5.1.1, 2.5.1.2 and 2.5.1.3. If either the PSC or any of the assigned PSAs will not be on site during the project work scheduled, Owner must be notified in writing with a detailed plan for replacement no less than two (2) weeks prior to the absence (for non-emergencies only) or as soon as the safety person's status is confirmed (for emergencies only). An acceptable replacement must be provided if the absence will be for more that twenty-four (24) continuous hours in any week or as directed by the ODR. If any other work (nights, weekends, or holidays) is planned, the crew size of that specific shift shall determine the number of safety personnel required, but at least the PSC or one (1) PSA must be on site during any work activities. The number of safety persons on site during nights, holidays, or weekends must be with written concurrence of the ODR.**

2.6 SUBCONTRACTOR'S SAFETY REPRESENTATIVE (SSR)

2.6.1 Each tiered Subcontractor shall declare one (1) or more employees to be its designated SSR. The SSR shall be dedicated to the Project for on-site safety responsibilities. This position cannot be delegated to another tiered contractor.

2.6.2 The SSR may have collateral duties, but must be on the Project site when any part of the applicable Subcontractor's work is being performed. The PSC shall formally approve each SSR prior to the commencement of work for that subcontractor.

2.6.3 Each first-tier Subcontractor's SSR shall possess a certificate of completion for the OSHA 30-hour Outreach Training in the Construction Industry. Remaining tiered Subcontractor SSRs shall possess at least a certificate for the OSHA 10-hour Outreach Training in the Construction Industry. Certificates must be dated within four (4) years of the executed Subcontract. Only a sub-tiered contractor that will have no more than three (3) workers on the project during their entire scope of work may petition to be excluded from this requirement. Any exception shall be by written approval of the ODR.

2.7 CONTRACTOR PROJECT SAFETY MANAGEMENT PLAN (PSMP)

2.7.1 The Contractor shall develop, implement, and furnish adequate resources for their PSMP.

2.7.2 The objectives and intent of the PSMP shall include, but not be limited to:

2.7.2.1 Anticipating, planning, controlling and coordinating work to eliminate hazards, minimize risks, and aggressively manage losses involving injuries or property damages;

2.7.2.2 Ensuring education and training for best safety practices by all workers and holding supervisors accountable for safety performance;

2.7.2.3 Documenting and recording preventative measures, establishing inspection, notification, and investigation requirements, and measuring results of performance;

2.7.2.4 Providing protection for adjacent property and safety for the public.

2.7.3 The PSMP shall address the inclusion of the Owner SafetyNet Program for electronic collection of safety observations. The terms of this Owner directed Program shall not be replaced by any existing program including any existing version of the SafetyNet Program already used by the Contractor. Within fourteen (14) calendar days of the issue of the NTP, the Contractor shall have available a means to record field observations.

2.7.4 The Contractor shall submit a complete draft of the PSMP to the ODR for review and written acceptance prior to the issuance of NTP for construction services. The Contractor shall incorporate ODR comments into a final draft and shall resubmit the amended version to the ODR within thirty (30) calendar days following the return date of ODR comments to the initial draft.

2.7.5 Beginning with the Notice to Proceed for Construction Services, the PSC shall formally evaluate and update the PSMP and its supporting documentation as construction activities dictate, but at least semi-annually to ensure effectiveness and continuous improvement. The PSC must provide means to verify required evaluation and update.

2.8 PERSONAL PROTECTIVE EQUIPMENT (PPE)

2.8.1 PPE shall be required for all persons in construction areas. The following items shall be furnished, inspected, and maintained by the employer:

2.8.2 Hard Hats shall be ANSI stamped (Z89.1-1997, Type I, Class E, G and C). Hard Hats shall be worn 100% of the time in construction areas, with the brim forward (or as allowed by the manufacturer). “Cowboy” style hard hats shall not be allowed (even if ANSI stamped). Hard hats with noticeable wear or damage shall be replaced. Each hard hat shall be examined by the PSC or PSA during the Project Safety Orientation to confirm acceptable condition.

- 2.8.3 Eye Protection (Safety Glasses) shall be stamped ANSI Z87. If a worker wears prescription glasses (plastic lens only) that are not marked Z87, the employer shall furnish goggles or safety glasses that are designed to fit over another pair of glasses. Eye Protection (Safety Glasses) shall be worn 100% of the time in construction areas. Anytime power actuated tools, electric or air operated grinding tools, electric or air operated impact tools, chop saws, masonry saws, chainsaws, or drilling tools are used, double eye and face protection shall be worn. Protection must be designed to prevent any air borne material from penetrating between the protection and the eyes.
- 2.8.4 High visibility vests or high visibility upper body clothing (equivalent to ANSI Class 2 or greater as applicable) shall be worn in the construction area. Primary work activities such as traffic control, excavations, rigging from ground level, exterior work at ground level or sub-ground level, earth moving operations may require ANSI Class 3.
- 2.8.5 The Contractor shall purchase and maintain an appropriate inventory of types and sizes to be able to furnish a hard hat, pair of safety glasses and vest for up to ten (10) Owner representatives who may visit the Project.
- 2.8.6 Hearing Conservation and Protection shall meet or exceed OSHA requirements. Except for suppression of sound energy level, no devices or equipment shall be placed in or over the ears. Portable radios, cell phones or any other electronic devices shall not be used by the general work force for any reason while in the construction areas. Use by supervision, project management, and safety persons is allowed for work related and emergency communications only. Any additional persons using these devices must be by written concurrence of the ODR. Music devices with or without ear pieces are strictly prohibited by anyone while in the construction areas. The Contractor may designate an area inside the limits of the project but outside of the active construction area where use of cell phones are allowed during scheduled breaks and lunch only. Location must be by written concurrence of the ODR.
- 2.8.7 Hand Protection that is designed to counter the potential for injury exposure shall be furnished to all workers who must handle materials or equipment with sharp edges, slick surfaces, chemically reactive components or extreme temperatures.
- 2.8.8 Respiratory Protection shall meet or exceed OSHA requirements.
- 2.8.9 Foot Protection (work shoes) must have soles with a resistance to punctures, uppers that cover the entire foot and ankle and offer resistance to scrapes and cuts. Sandals, open toed shoes, dress loafers, high-heels, and all athletic style shoes (including those with ANSI markings) are prohibited. Additional protection such as metatarsal guards over work shoes (including steel toe boots) shall be provided when work operations create impact exposures.
- 2.8.10 Other OSHA required PPE shall be furnished as appropriate for specific tasks.

2.8.11 Other clothing:

2.8.11.1 Shirts shall not have noticeable holes and shall be free of profane, inflammatory, sexually explicit or discriminatory messages. Sleeve length shall cover the ball of the shoulder and shirt length shall reach waist of pants. Shirts shall not provide snag points.

2.8.11.2 Pants shall be full length. Holes must not be large enough to provide snag points or offer measurable amounts of exposed skin.

2.9 MEDICAL EQUIPMENT

2.9.1 The Contractor shall purchase and maintain at least one (1) First Aid Kit on the Project site as per the current version of ANSI Z308.1. Depending on the size, configuration of the site, travel distance to retrieve, and time required to administer medical treatment, additional First Aid Kits may be required. The kit(s) should be readily available as needed.

2.9.2 The Contractor shall purchase and maintain at least one Automatic External Defibrillator (AED) unit on the Project site. The unit shall be located in the Contractor project site office with appropriate signage and must be accessible whenever work is ongoing. Depending on the size, configuration of the site, travel distance to retrieve, and time required to administer medical treatment, an additional AED unit may be required.

2.9.3 A minimum of two (2) Contractor employees, with current certifications for First Aid / CPR and for use of the AED, shall be at the Project whenever work is being performed.

2.10 WORKER TRAINING

2.10.1 **All workers shall be trained to perform their specific task(s). Formal documentation to support claimed training must be provided. Acceptable documentation for all certifications and training claimed shall contain name of the training organization, name and title of the trainer(s), date of training, material covered with time spent on each topic, and evaluation process used to determine worker understanding of training. Documentation must be provided by the training organization. The database of employers' workers must be kept up to date and accessible for review as requested. No work or operations may commence without the PSC having completed review and acceptance under this Section. The ODR reserves the right to determine acceptability of training being claimed.**

2.10.2 **For every brand and model of crane and motor driven equipment (earth moving, lift platforms, suspended stages, material handling, etc.) brought onto the Project, the using company shall transmit to the PSC a list of employees who are trained and authorized to operate that brand and model of equipment. Copies of training documentation in addition to any required certifications shall be provided. In addition, cranes shall be operated only by persons who possess**

certification from an organization that carries nationally recognized accreditation. Industrial Trucks (forklifts) shall only be operated by persons who have been certified by their employer. Individuals who possess required credentials shall demonstrate acceptable proficiency to the PSC or PSA.

2.10.3 For every position that is required to assist with crane and motor driven equipment operations (flaggers, signal persons, riggers, spotters, etc.), the using company shall transmit to the PSC a list of employees who are trained and authorized to perform these functions.

2.11 PROJECT SAFETY SIGNS AND POSTERS

2.11.1 The Contractor shall post a pair of safety regulation signs at every point of entry to the Project: one in English and one in Spanish. Font shall be black in color and sized in each language to completely fill the surface of a white-coated four-foot (4') vertical by eight foot (8') horizontal sheet of 3/4-inch plywood and shall contain only the following text:

ALL VISITORS, DELIVERY PERSONS, AND NEW WORKERS MUST REPORT TO THE PROJECT OFFICE BEFORE ENTERING ANY CONSTRUCTION AREA.

ALL PERSONS ENTERING ANY CONSTRUCTION AREA MUST WEAR STURDY WORK SHOES, PROPER CLOTHING, A HARD HAT AND SAFETY GLASSES AT ALL TIMES – NO EXCEPTIONS ARE ALLOWED DURING WORK HOURS.

POSSESSION OF WEAPONS, ALCOHOLIC BEVERAGES, CONTROLLED SUBSTANCES, OR DRUG PARAPHERNALIA WILL RESULT IN IMMEDIATE REMOVAL FROM THIS PROPERTY.

EXCEPT WHERE DESIGNATED (BY POSTED SIGNS AND AVAILABLE RECEPTACLES), USE OF ANY TOBACCO PRODUCT IS PROHIBITED ON THIS PROJECT

THE MAXIMUM SPEED LIMIT FOR ALL VEHICLES ON THE PROJECT SITE IS NINE (9) MPH – LOWER SPEED MAY BE REQUIRED BY POSTED SIGNS IN SOME AREAS.

ONLY AUTHORIZED VEHICLES ARE ALLOWED ENTRY INTO CONSTRUCTION AREAS.

2.11.2 The Contractor shall post a notice sign at the project office in English and Spanish. Font shall be black in color on a white coated board and size of letters shall be at least three inches (3") in height, and shall contain at least the following text:

VISITORS, DELIVERY PERSONS AND NEW WORKERS MUST CHECK-IN HERE FIRST.

COPIES OF SAFETY DATA SHEETS (SDS) FOR MATERIALS THAT WILL BE USED OR STORED ON SITE MUST BE DELIVERED BY ALL SUBCONTRACTORS TO THIS LOCATION AND SHALL BE AVAILABLE TO ANY REQUESTOR.

2.11.3 The Contractor shall also post the following in locations that may easily be viewed by workers:

2.11.3.1 Color Codes for Quarterly Equipment Safety Inspections:

- 2.11.3.1.1 1st Quarter = White (January 01– March 31)
- 2.11.3.1.2 2nd Quarter = Green (April 01 – June 30)
- 2.11.3.1.3 3rd Quarter = Red (July 01– September 30)
- 2.11.3.1.4 4th Quarter = Orange (October 01 – December 31)

2.11.3.2 Emergency contacts list, including mobile phone numbers

2.11.3.3 Hazard Rating Guide (HMIS and/or NFPA)

2.11.3.4 Insurance Provider for Worker’s Compensation Coverage for the Project

2.11.3.5 Others as required by Federal and/or State regulation

2.12 PROJECT SAFETY FILE DOCUMENTS

The Contractor shall create and maintain files for Owner review. The following files shall be established in one location on the Project and shall be made accessible to Owner agents during working hours. Additional files shall be created as directed by the ODR.

- 2.12.1 Project Safety Management Plan (PSMP)
- 2.12.2 Project Safety Management Plan Evaluations
- 2.12.3 Project Safety Orientation Checklists
- 2.12.4 Project Access Log
- 2.12.5 Project First Aid Log
- 2.12.6 Project Incident Notification, Investigation, and Evaluation Reports
- 2.12.7 All Qualified Person Certifications and Training Documentation
- 2.12.8 Project Competent Persons Lists
- 2.12.9 Project Equipment and Crane Operators Lists
- 2.12.10 Job Hazard/Safety Analysis (from each Subcontractor per operation)
- 2.12.11 Project Weekly Safety (“Tool Box”) Meeting
- 2.12.12 Project Weekly Subcontractor Safety Representative (SSR) Meeting Minutes
- 2.12.13 Contractor Monthly Safety Report
- 2.12.14 Project Quarterly (Portable) Equipment Inspection Reports
- 2.12.15 Project Annual (Large) Equipment Inspection Reports
- 2.12.16 Project Permits (Closed Out)
- 2.12.17 Project Safety Infraction Records
- 2.12.18 Site Specific Safety Plan for Each Subcontractor on the Project
- 2.12.19 Drug / Alcohol Testing Confirmation Documentation
- 2.12.20 Subcontractor’s Return to Work Policy and Acknowledgement
- 2.12.21 Contractor UTS Safety Specification 01 35 23 Requirements Acknowledgement

PART 3 – EXECUTION

3.1 POSITIONS, ROLES AND REQUIREMENTS FOR PROJECT SAFETY

3.1.1 Contractor's Project Superintendent and Project Manager

The Project Superintendent and Project Manager shall remain actively engaged and share responsibility for project safety throughout construction. Both shall support the PSC and PSA when actions are required to maintain a safe work environment at the Project. Project safety shall never be compromised to achieve any other business objective.

The Project Manager shall ensure that ALL tiered subcontractors receive a copy of the UTS Safety Specification 01 35 23 prior to the execution of a contract (Exhibit N) and ALL required safety documentation is submitted for review and acceptance by the PSC prior to the subcontractor's work start on the project.

3.1.2 Project Safety Coordinator (PSC)

3.1.2.1 The PSC shall report directly to a corporate safety officer of the Contractor and shall not report through the Contractor's Project Management team.

3.1.2.2 If removal of the PSC is initiated by the Contractor, the existing PSC shall remain in position until a replacement candidate has been proposed to and accepted by the ODR in writing and is specifically assigned to the Project. If the PSC leaves before the proposal and acceptance procedure is concluded, the Contractor shall temporarily install either a Safety Director (Regional or Corporate) or a professional construction safety consultant as the PSC until a suitable replacement is accepted in writing by the ODR. Any temporary replacement must meet the qualification levels, perform the duties, and be present full time on the Project as required of the PSC in order for work to proceed. A permanent replacement shall be accomplished within thirty (30) calendar days.

3.1.3 Project Safety Assistant (PSA)

3.1.3.1 The PSA shall report to and perform duties as directed by the PSC.

3.1.3.2 If removal of a PSA is initiated by the Contractor, the existing PSA shall remain in position until a replacement candidate has been proposed and accepted by the ODR in writing and is specifically assigned to the Project. If the PSA leaves before the proposal and acceptance procedure is concluded, the contractor shall temporarily install either a Safety Director (Regional or Corporate) or a professional construction safety consultant as the PSA until a suitable replacement is accepted in writing by the ODR. Any temporary replacement must meet the qualification levels, perform the duties, and be present full time on the Project as required of the PSA position. A permanent replacement shall be provided within thirty (30) calendar days.

3.1.4 Both PSC and PSA

- 3.1.4.1 The PSC and PSA shall have the authority to direct Contractor and Subcontractor personnel to correct any safety deficiency.
- 3.1.4.2 The PSC and PSA shall have the authority to stop any operation(s) that involves any level of risk.
- 3.1.4.3 The PSC and PSA shall be fluent in English and have immediate access to the necessary resources to communicate verbally with all workers on the Project.
- 3.1.5 Subcontractor Safety Representative (SSR)
 - 3.1.5.1 The SSR name, emergency contact information, and documentation of qualifications shall be submitted to and accepted by the PSC prior to the commencement of any work activities by the Subcontractor. Per this section, at least one SSR is required; however, the Subcontractor must plan for and make available as needed a qualified replacement should the primary SSR not be on site. The SSR shall have the authority to direct actions, stop work and enforce discipline for safety issues.
 - 3.1.5.2 The SSR shall submit a written task specific Job Hazard/Safety Analysis (JH/SA) daily and as work conditions change for each of the risk exposures associated with the employer's portion of the work. Documentation of attendees and subject material covered must be provided by the SSR. Each submittal shall be reviewed and accepted by the PSC or PSA prior to commencement of the work operation that will create the exposure.
 - 3.1.5.3 The SSR shall attend the Project Weekly Subcontractor Safety Representatives Meeting when their company is actively performing work at the Project.
 - 3.1.5.4 The SSR shall accompany any injured worker that requires medical attention at a facility outside the Project. The SSR shall be responsible for notification to the PSC of any incident including near misses, and shall complete all the documents required to manage any insurance claims. The SSR shall participate in incident investigations that involve their employer's portion of the work.
 - 3.1.5.5 Each SSR may be required to accompany the PSC or PSA during portions of each safety inspection that involves the Subcontractor's scope of Work.
 - 3.1.5.6 The SSR shall ensure that planning, training, equipment and materials are provided so that workers can perform their duties safely.
- 3.1.6 Work Crew Supervisor, Equipment Operator, Competent Person, Qualified Person Medical Responder
 - 3.1.6.1 Supervisors, Equipment Operators, Competent Persons, and Medical Responders for each of the positions held, shall be recognized by the employer through formal

submittal to the PSC. Documentation of training with applicable certification shall be maintained in the Project safety file.

- 3.1.6.2 Designations of certifications and qualifications for special roles shall be clearly displayed on the back of the worker's photo identification badge.

3.2 PROJECT SAFETY MANAGEMENT PLAN (PSMP)

- 3.2.1 Safety Mission and Policy Statement. The Contractor's Safety Mission Statement shall include a commitment to create and maintain a work environment that will eliminate or minimize all risk exposures for all workers at the Project. The Safety Policy Statement shall include acknowledgement that the Contractor is accountable for providing and controlling a safe environment for all workers and members of the public. An original signature and date to endorse and assure commitment by a Corporate Executive or Business Owner shall be affixed to this element of the PSMP. The PLAN shall include the following as a minimum:
 - 3.2.2 Safety Roles and Responsibilities. This element shall outline and describe roles, responsibilities, and authority of each member of the Project staff for involvement in site safety, security, incident command, and incident claims management. The Contractor's Project organization chart shall indicate the reporting line for the PSC and PSA(s) as applicable. The PSC or PSAs shall not be responsible for activities associated with insurance enrollment and maintenance or any other duties not directly related to project safety. Administration (clerical) duties related to safety can be transferred to another member of the Project staff. Overall intent is to maximize time in the field by the PSC and PSAs.
 - 3.2.3 Safety Enforcement. This element shall include the Contractor's disciplinary procedure for its own employees and for those of all Subcontractors. It shall include a description of the levels of severity and frequency (repetition) that will result in Contractor intervention and provide details of the retraining and/or disciplinary steps that will ensue from the possible combinations of unsafe behaviors. It shall also include discipline for supervisors who tolerate risk.
 - 3.2.4 Safety Recognition and Commendation. This element shall include a description of how those workers who demonstrate exemplary safety behavior and those supervisors who manage, enforce, educate and promote safety will be recognized and commended. Any celebration that will occur as part of this element shall not be minimized with achievement of Project milestones that are associated with production, schedule, quality or budget. The Owner supports the use of a Safety Commendation Program (SCP) as long as it is part of a more comprehensive safety program. Any commendation program must encourage worker participation, reinforce safety training, promote safe behavior and practices, and support continuous improvement of the safety process on the project. No SCP shall be implemented that would discourage reporting of injuries, illnesses, property damage or unsafe working conditions. The SCP shall be prudent, economical, simple, and with a greater focus on daily positive feedback and commending safe work

behavior than providing expensive or extravagant commendations. The SCP plan shall be submitted for Owner review and approval prior to implementation, and must include details regarding quantity and cost of suggested commendations. **Note: If utilization of vendor donated items for commendations are anticipated, those items will be evaluated to confirm that they are reasonable and appropriate.*

3.2.5 Safety Hazards. This element shall include a narrative that recognizes existing site conditions, foreseeable changes to existing conditions, local climate, Owner and public interface, environmental impact and remediation issues, skill and experience levels of available work force, utility interruptions, water supply sources, power supply sources, Owner facility provisions, sanitation requirements, parking, material storage areas, and proximity to students and public walkways and roadways. It shall contain a completed copy of the Anticipated Project Hazards Checklist (EXHIBIT A). It shall also be expanded throughout the duration of Work to include Subcontractor plans for elimination or minimization of risk. All portions of this element shall be consistent with existing procedures for the campus Environmental Safety and Health department, the campus Security department, and local municipal Fire and Rescue.

3.2.5.1 Hazard Communication (“HazCom”). Insert the elements required by OSHA. The PSC shall maintain a Hazardous Materials Inventory List with individual SDS for each and every hazardous substance brought onto the Project site. In addition to the product label of contents, all containers with at least five (5) gallons of fluid capacity or twenty (20) pounds of chemical content shall include either HMIS or NFPA hazards warning labels (except drinking water and fire extinguishers). All products with HMIS/NFPA number ratings greater than zero, or one in any of the three categories (health, flammability, or reactivity), shall be considered as hazardous.

3.2.5.2 Environmental (Sensory) Hazards. Insert actions to measure worker exposures and to control hazards that may exist beyond OSHA permissible exposure limits (i.e. dust, fumes, noise, chemicals, respirable silica, and extreme temperatures). Also, include control and remediation plans for incidents that result in a spill or discharge of a potentially hazardous or toxic substance (liquid or gas). If lasers will be used, include plan to control worker exposure.

3.2.5.3 Roadway and Traffic Hazards. Insert actions to be taken at times when public roadways or sidewalks are affected by construction activities. Signs, devices, and procedures shall be identified where public passage is to be closed or altered. Procedures and training for flaggers shall be required and shall be in compliance with all applicable Texas Department of Transportation (TxDOT) regulations for road safety; specifically, the Texas Manual on Uniform Traffic Control Devices (TMUTCD) shall be referenced.

3.2.6 Fire Prevention and Control

3.2.6.1 Insert arrangements and equipment necessary to provide adequate protection during all phases of construction. All portions of this element shall be developed to be

consistent with existing procedures of the campus Environmental Safety and Health department, the campus Security department, and local municipal Fire and Rescue.

3.2.6.2 Burning, Welding, Flame Operations. Insert the process for issuance of a “HotWork” permit (EXHIBIT B). Daily permit forms shall be issued by the PSC or PSA, even if the campus Environmental Health and Safety department desires to be involved and issues a campus permit. The permit form shall be completed by the SSR and returned to the PSC or PSA for field verification of noted conditions and written acceptance prior to start of operation. All permits shall expire at the end of the shift. Permits shall identify the fire watcher(s) and require pre-operation and post operation inspections.

3.2.7 Emergency Response. Describe each type and level of emergency that may reasonably be expected to occur on the Project. Insert response or rescue plan for each kind of potential emergency. This element shall address first aid, off-site medical care, property damage, rescue, project alarm signals, wind, flood, lightning strikes, and evacuation, threat of violence, protests or deliberately disruptive events. NOTE: A designated Campus Spokesperson shall be the only person authorized to communicate with the media. This element shall include a drawing or sketch of the site (maintained for “as built” conditions) to indicate gates, emergency vehicle roadways, lay down areas, crane set up positions, exterior hoists, etc. All portions of this element shall be developed to be in accord and cooperation with existing procedures for the campus Environmental Safety and Health department, the campus Security department, and local municipal Fire and Rescue.

3.2.7.1 Incident Notification. Insert the list of personnel with mobile phone, email, position and company information who may be contacted. The ODR and others as directed shall be included in the incident notification process. Depending on potential severity of the incident, notification may be in written and/or verbal form as directed. Incident notification flow shall be as indicated in EXHIBIT K. Indicate specific positions within the campus staff that may be contacted and/or involved in the notification and control process; i.e. site control and utility management. Campus Public Relations (PR) officer shall be the only person authorized to release live or pre-recorded video or written statements to the media. The Contractor shall cooperate with campus PR officer and coordinate media arrangements as directed.

3.2.7.2 Site Security. Insert actions and control measures to prevent intrusion during work and non-work hours. Describe intended controls for perimeter security, gate security, pedestrian crosswalks, protection at public paths through and alongside construction areas, warning signage, etc. Identify special work that may not be performed during regular hours, and will require special precautions. Include descriptive detail for some method of gathering names and probable locations of workers who have not been cleared for safe departure during any type of emergency. Identify the position(s) of all who will possess this information and be prepared to convey critical details quickly to any outside emergency response command that might arrive at the Project.

- 3.2.8 **Project Trenching, Tunneling and Excavation. Insert soil boring reports, soil classification analysis, site sketch and any other information that may support, explain or clarify the intent of this element. In addition to requirements in the UGC, this element must be stamped and sealed by a Registered Professional Engineer recognized in the State of Texas in the field of Civil or Soils Engineering.**
- 3.2.9 Drug and Alcohol Impairment. The Contractor, for itself and all Subcontractors, shall have a robust drug and alcohol screening and intervention plan. Insert details of the Contractor policy for screening both direct employees and Subcontractor employees for the presence of controlled substances, prescription pharmaceuticals, and alcohol. Describe all of the types of testing and confirmation that the Contractor requires and the tolerance thresholds for each substance. This element shall include, as a minimum, a detailed explanation of the following situations and mandatory testing events:
- 3.2.9.1 **Pre-project entry – Test results conducted within two weeks preceding issuance of badge for Project access. Proof of testing must be documented by company letter with representative name and title, date of testing, location of testing, indicates that testing meets or exceeds the NIDA 5 panel for drugs and DOT for alcohol, name of each tested worker, and results. Results must be negative. Other drug/alcohol testing may be required while working on the project. ANY positive test result requires removal of the worker from the project. Any worker that has been off the project for more than sixty (60) consecutive days must also be retested within the two weeks requirement prior to re-entry.**
- 3.2.9.2 Post-incident
- 3.2.9.3 Random selection
- 3.2.9.4 Suspicion
- 3.2.10 Concrete (for slip-form, crane bucket, pump truck, cast-in-place)
- 3.2.11 Confined Space Entry (Permit Required and Restricted Entry)
- 3.2.12 Crane Operations (for set-up/use requirements and limitations)
- 3.2.13 Demolition (Mechanical and/or Explosive Blasting)
- 3.2.14 Electrical Power Service (address power supply and use during construction)
- 3.2.15 Fall Prevention and Protection (from elevations and at same level)
- 3.2.16 Hand and Power Tools
- 3.2.17 High Voltage (“Proximity Work”)

3.2.18 Ladders and Stairs

3.2.19 Lock-out, Tag-out (Energy Isolation for sudden release of any kind of energy)

3.2.20 Respiratory Protection

3.2.21 Safety Inspection

3.3 PROJECT SAFETY MEETINGS AND TRAINING

3.3.1 Project Initial (Safety Kick-Off) Meeting

3.3.1.1 At any time within, but no later than, fifteen (15) calendar days after the issuance of the Notice to Proceed for Construction Services, the Contractor shall arrange suitable accommodations and the Owner PM or RCM will schedule and chair the meeting. Minimum attendance shall include the Owner PM, Construction Inspector(s), OSR, Contractor's PM, Superintendent, PSC and PSA, and Contractor's Corporate Safety Representative. Additional representatives for the Owner, the Institution, the A/E, the Contractor and local regulatory entities may also attend.

3.3.1.2 The Contractor shall confirm the schedule availability for all non-Owner attendees at least fourteen (14) calendar days prior to the meeting date.

3.3.2 Initial Meeting with Subcontractors for acknowledgment of Safety Requirements

3.3.2.1 At any time after the date of intent to award each first tier Subcontract, but prior to commencement of any work, the Contractor shall arrange and chair a documented meeting with Subcontractor to explain safety requirements. Minimum attendance shall include the Owner Construction Inspector(s), Contractor's PM, Superintendent, PSC, PSA, and SSR. Other interested parties for the Owner and Contractor may also attend. Any lower-tier Subcontractors that have been awarded part of the work shall also attend. A copy of Exhibit N to this specification is to be signed by representatives from each subcontractor and submitted to the ODR.

3.3.2.2 In addition to all of the pertinent safety regulations that apply to the portion of the work that the Subcontractor will perform, the Contractor shall clearly state the expectation that safety management of its workers and Sub-tier workers shall be the Subcontractor's responsibility and that failure to adequately manage safety could result in a demand for the removal and replacement of supervisors.

3.3.3 Project Safety Orientation Training – All Dedicated Project Workers

3.3.3.1 The PSC or PSA shall conduct formal training to every dedicated project worker who is to be allowed into the construction area(s) without an escort. This duty shall not be delegated. Unless the PSC and/or PSA are bi-lingual, a translator shall be present when there are workers in attendance who do not speak English. Workers and their

immediate supervisors shall be required to attend a repetition of the orientation whenever observed behavior indicates a lack of understanding or repeated non-compliance of project safety requirements.

- 3.3.3.2 The PSC shall review the Safety Orientation Checklist (EXHIBIT D) and incorporate each applicable topic within the presentation. The PSC shall develop and administer a process to ensure and demonstrate worker understanding.
- 3.3.3.3 The PSC shall furnish a photo-identification badge to each dedicated project worker who satisfactorily completes the Project Safety Orientation. The badge will indicate the worker's name, employer, job title, project name, and Owner project number. The badge must be visible at all times that the worker is on the Project and be located above the waist using clip or arm band. Lanyards are prohibited. Failure to maintain the badge will be grounds for removal from the Project. Operator qualifications for specific equipment that can be operated will be identified on the back of the worker's photo identification badge. ID badges shall not be issued to visitors.
- 3.3.3.4 The PSC shall confirm employer insurance requirements have been met and that all required documentation is on site and has been reviewed and found acceptable prior to start of orientation. PSC shall confirm documented credentials for operators and SSR prior to start of orientation. The PSC shall maintain a site access log to document each successful orientation and any reorientations. The log shall include Project critical information (name, employer, badge number and position).

3.3.4 Daily Job Hazard / Safety Analysis (JH/SA) Training

- 3.3.4.1 Prior to start of the work for each shift, the SSR shall conduct a meeting with all members of the work crew to explain how the work steps for the shift are to be accomplished. Explanation shall include a discussion of all the work activities that will be performed in the vicinity as well as the work that the crew is expected to accomplish. Explanation shall address all of the recognized risks associated with the task and the hazard controls to be installed or actions to be taken to eliminate or minimize the exposures. Actions to be taken in the event of an emergency shall also be included and documented.
- 3.3.4.2 **A daily JH/SA shall be produced to document this meeting. (Exhibit M – Mandatory)** It shall contain names and initials of all attendees, name of supervisor (SSR if same), a project specific daily statement of task(s), and any special safety measures or actions that are required to assure elimination or minimization of risk. A copy of the JH/SA shall be reviewed in the field comparing planned and actual work and endorsed by the PSC or PSA prior to work activities and copies of any completed permits shall be clipped to the document. The supervisor's and workers' signatures on the JH/SA shall be understood to also mean a thorough communication of all anticipated hazards and controls has been provided to all workers. A copy of the JH/SA will be posted in the immediate work area (considered to be within 75 feet) until the daily activities are complete. The JH/SA shall be modified as work activities

change, warranting additional review and communications to the affected workers throughout the shift. Modified JH/SA must be re-reviewed and endorsed by the PSC or PSA prior to work re-start.

- 3.3.4.3 Project Management team members (Owner, Contractor and Subcontractor) are expected to attend these JH/SA meetings as frequently as possible to reinforce the Project safety culture.

3.3.5 Project Weekly Subcontractor Safety Representatives Meeting

- 3.3.5.1 The PSC shall chair a weekly meeting with all SSR(s) to ensure that all are aware of the existing hazards and exposures that should be addressed with each crew. A written agenda (EXHIBIT E), attendance roster, and meeting minutes shall be prepared and maintained at the Project site by the PSC.

- 3.3.5.2 This meeting shall be exclusively reserved for safety and hazard control issues. Attendance shall be required of all SSR(s) when their employer is actively conducting work operations on the Project. Project Management team members (Owner, Contractor and Subcontractor) are expected to attend these weekly meetings as frequently as possible to reinforce the Project safety culture.

3.3.6 Project Weekly Site Safety (“Tool Box Talk”) Meeting

- 3.3.6.1 All workers on the project site, including site Project Management team members, shall attend a weekly safety Tool Box Talk, which shall be presented in English and all other languages that are natively spoken at the Project. The PSC or PSA may deliver each talk to the entire Project population or each SSR may deliver individual meetings to their specific trade and/or group. The PSC or PSA shall periodically participate and review individual meetings to ensure effectiveness. The PSC or PSA shall collect and maintain copies of all sign-in sheets for every meeting.

- 3.3.6.2 Meetings shall address appropriate topics for the current and future work operations and current site conditions. In addition, the PSC or PSA shall communicate information regarding statewide safety results discussed during Monthly PSC Conference Calls, inspection results, and other project safety-related topics.

3.3.7 Periodic PSMP Review and Lessons Learned

The Contractor shall work with the Owner to use Lessons Learned to capture significant safety experiences and best practices over the course of the work. The Contractor will work with the Owner to facilitate Lessons Learned at Substantial Completion and will work with Subcontractors to actively participate in Lessons Learned. The Contractor shall develop and distribute any reports that detail findings to the ODR as requested. The PSC shall formally evaluate and update the project safety process and supporting documentation as construction activities dictate, or at least semi-annually to ensure effectiveness and

continuous improvement. Modifications after each review shall be submitted to the ODR for review and acceptance.

3.4 SAFETY INSPECTIONS

3.4.1 Daily SafetyNet Inspections

- 3.4.1.1 Project safety inspections shall be entered into SafetyNet. The OSR(s), Owner PM and CI, PSC and PSA, shall all be recognized users of the Owner's SafetyNet Program. Other persons such as the Contractor's project management team and the sub-contractor's SSRs are expected to participate in daily project inspections. Information entry into SafetyNet conducted by these individuals shall be through the PSC or PSA.
- 3.4.1.2 User participation shall include recording of all observations and conditions at the Project (via the Program's menu-driven checklist). Additionally, the PSC shall review on-line reports and respond appropriately, detailing sustainable action(s) taken to correct the identified safety process deficiencies.
- 3.4.1.3 Each deficient safety observation shall be corrected or controlled immediately. The PSC shall be responsible for reviewing and ensuring proper closure of all unresolved ("open issues") observations. ODR shall concur prior to closure.
- 3.4.1.4 An OSR will conduct initial training for the PSC understanding and use of the SafetyNet Program. All subsequent training of PSA(s) shall be accomplished by the PSC.
- 3.4.1.5 At a minimum, a daily SafetyNet inspection shall be conducted by each PSC and PSA on site during the shift. The daily inspection may only record a group of observations within a single work operation, but the accumulated inspections conducted by the PSC and PSA throughout each work week shall reflect a comprehensive report of all operations at the Project. Each inspection shall be entered into SafetyNet within twenty-four (24) hours of the inspection. All inspections for the current month must be entered into SafetyNet no later than the last day of that month.
- 3.4.1.6 When an OSR conducts an inspection, the PSC and/or PSA shall be available to join in during the walk around. Other Owner users will also require the PSC and/or PSA to participate in the inspections.
- 3.4.1.7 When the PSC or PSA conducts an inspection, at least one SSR shall join in for the portion of the inspection that addresses the Subcontractor's scope of Work.

3.4.2 Quarterly (documented) Inspection of all tools, rigging, and portable equipment

- 3.4.2.1 In addition to the required daily equipment inspection by the user, the PSC shall facilitate a documented safety inspection each quarter. Each contractor shall produce and submit a document (EXHIBIT F) that addresses all tools, rigging, and portable equipment within the company's inventory on the Project site. Documentation evidencing inspections shall be maintained by the PSC.

3.4.2.2 This inspection shall include, but not be limited to, the following: Fall Arrest / Restraint Equipment, Rigging, Manufactured Ladders, Job Built Ladders, Power Tools, Electrical Cords, Welding Leads, Hoses, First Aid Kits, AEDs, Atmosphere Monitoring Meters, and Ground Fault Circuit Interrupter devices. Personally owned hand tools are exempt from this inspection procedure, but daily examinations of all portable items prior to start of work shift as prescribed by the equipment manufacturer and/or OSHA standards are not relaxed.

3.4.2.3 For every item that “passes” the quarterly inspection, the SSR must remove the previous quarter’s color coding and affix the current quarter’s color coding. The PSC shall establish a universal system for the placement of the color coding for each individual piece of equipment identified in Section 3.4.2.2 (i.e., male end of an extension cord, spreader bar on portable step ladder, etc.) Every item removed from service shall be repaired, replaced, destroyed or immediately removed from the Project. The inspection report shall reflect such actions. Inspection reports shall be completed by the SSR and submitted to the PSC prior to use of any new equipment on the Project site and re-inspections before the first calendar day of the beginning of each quarter of the year. Quarterly re-inspections may begin and color coding may be changed anytime during the final one-week period of the previous quarter.

3.4.3 Initial and Annual Inspection of all Cranes and Motor Driven Equipment

3.4.3.1 The PSC shall ensure manufacturer required safety inspections and written certifications for all hoists, cranes, mobile equipment, motorized scissors and aerial lift platforms, motorized stage platforms, generators, and compressors are maintained on the Project.

3.4.3.2 The PSC shall ensure that all equipment inspections are consistent with the manufacturer’s requirements. An initial inspection and certification of proper condition shall be transmitted to PSC before a piece of equipment is allowed to commence operations on the Project.

3.4.3.3 The PSC shall ensure all equipment is inspected annually and certified as required prior to initial use. Any equipment that leaves the Project and returns will require re-certification before it shall be allowed to resume operation at the Project.

3.4.4 Inspections by Regulatory Agencies

The PSC or PSA shall notify the ODR immediately of the arrival at the Project site by a representative of a Regulatory Agency (OSHA Compliance Officer, TCEQ Representative, Law Enforcement Officer, etc.), and provide the ODR with a copy of any published findings or citations issued to any employer, and shall ensure that statutory posting requirements are met. PSC shall provide the ODR with a copy of any employer’s response to the same findings or citations.

3.5 CONTRACTOR RECORDS, INVESTIGATIONS AND REPORTS

3.5.1 Mobile Equipment and Crane Operator Records

Consistent with the requirements of Section 2.10.2, each employer shall submit to the PSC, for each operator, a record of training. The minimum amount of detail as applicable for the specific piece of equipment shall include the following:

- 3.5.1.1 Pre-start up inspection, travel path issues, and location/set up procedure;
- 3.5.1.2 Start up, operation, intended use, and shut down (normal and emergency);
- 3.5.1.3 Equipment Operations Manual, Limit Chart(s), Motor Plate information, equipment capacities and limitations, alarm features, safety stops, seat belts, roll over protection and preventive maintenance;
- 3.5.1.4 Any additional operational topics as indicated by the equipment manufacturer.

3.5.2 Contractor Monthly Safety Report

- 3.5.2.1 The PSC shall enter the following project information directly into SafetyNet; total man hours by month, all OSHA recordable and days away from work incidents including descriptions and relevant fields, near misses, first aid rendered, and property and equipment damage. Data shall be entered into SafetyNet no later than the 10th of the month following the reporting period.
- 3.5.2.2 This information is vital to the Owner's safety benchmarking efforts. Failure to submit the information in a timely manner may result in ODR withholding a portion of the Contractor application for payment, and shall disqualify the Contractor from consideration for safety recognition for the month of failure to submit as required.

3.5.3 Incident Notification, Investigation and Reporting Procedure

- 3.5.3.1 During the orientation, the PSC shall instruct all workers to immediately report every incident to their supervisor, even if there is no obvious injury or property damage. Supervisors shall immediately notify the PSC or PSA, who shall immediately notify the ODR of any incident. All Near Miss incidents, First Aid injuries, High Risk Safety Inspection Observations, and other such incidents as directed by the Owner shall be entered into SafetyNet by the PSC. All incidents shall be investigated. The PSC shall lead the efforts and follow a structured incident investigation program. The Contractor and involved subcontractors shall tailor the magnitude and depth of the investigation effort to correspond to the potential, rather than the actual outcome of the incident. Investigation team members shall include safety personnel, project management, line management, affected workers, and consultants as the circumstances dictate. The ODR reserves the right to participate in any incident investigation. The PSC shall develop a Root Cause(s) Analysis report (Exhibit J) that

summarizes the incident, identifies the underlying contributing factor(s), determines which process element(s) failed to control the incident, determines which process element(s) will be implemented or improved, and the time needed to take sustainable corrective action(s). PSC shall conduct and submit incident investigation report that supports the Root Cause(s) Analysis in the manner and time as directed by the ODR. The Owner reserves the right to determine the acceptability of the findings. The PSC shall prepare and submit reports that will allow the Owner and Subcontractors to understand findings and any planned changes to the PSMP based on those findings.

3.5.3.2 Incident Responsibilities for Workers and Supervisors

- 3.5.3.2.1 The PSC or PSA shall cover the information in the Worker Responsibilities (EXHIBIT G) document during the orientation and keep copies to hand out to any worker who appears to have sustained an occupational injury.
- 3.5.3.2.2 The PSC or PSA shall cover the information in the Supervisor Responsibilities (EXHIBIT H) document during the orientation and keep copies to hand out to any supervisor who informs PSC or PSA that a worker injury has occurred.

3.5.4 Contractor Final Safety Report

- 3.5.4.1 The PSC shall work with all contributing subcontractors to prepare a Final Safety Report and shall forward to the ODR no later than thirty (30) calendar days after Substantial Completion.
- 3.5.4.2 Report shall include at least the following items:
 - 3.5.4.2.1 Summary of the PSMP with description of improvement initiatives undertaken during the course of the Project
 - 3.5.4.2.2 Evaluation of the effectiveness of the PSMP, including summary results of assessments performed
 - 3.5.4.2.3 Project safety performance results (leading and trailing indicator measures)
 - 3.5.4.2.4 Project safety lessons learned and best practices
 - 3.5.4.2.5 Summary of Project incidents
 - 3.5.4.2.6 Evaluation of Contractor and all subcontractors overall safety performance
- 3.5.5 The Contractor shall provide additional reports as requested by the ODR. This may include work force histograms, training documents, safety trending reports, etc.

3.5.6 The PSC shall notify the ODR when a worker is removed from the project for a serious infraction, including any of the following reasons: refusal to take a post incident drug/alcohol screen or a positive result if taken, possession of a prohibited weapon on the project, criminal activity, use of equipment that jeopardizes the safety of any project worker, or fighting on the project. Within forty-eight (48) hours of removal, the PSC shall provide the ODR a brief report of finding(s) that resulted in the worker removal. Report must include the project name and location, the name of the removed worker, the legal name of the worker's employer, the date and time of the incident leading to the removal, and a brief summary of the facts justifying the removal.

3.6 CONSTRUCTION OPERATIONS

The following requirements are either in addition to or in the absence of Federal and State regulations. Where conflicts exist, the most stringent directives shall apply.

3.6.1 Cranes

3.6.1.1 Tower cranes (including affiliated transformers and power supply equipment) shall be surrounded by at least a sixteen-foot (16') high, 5/8-inch plywood enclosure with a lock-controlled entrance.

3.6.1.2 Operators of cranes shall be trained in the specific make and model of crane and possess certification from a nationally accredited certifying organization.

3.6.1.3 Every crane and piece of hoisting equipment shall be equipped with an anti-two blocking sensor above each lifting block.

3.6.1.4 Unless the crane is equipped with sensors that inform the operator of the weight of the load on the hook and the current wind speed, these measurements shall be determined by other means before commencement of each lift.

3.6.1.5 When outriggers are used on cranes, they shall be fully extended. Float pads shall be landed onto leveled and properly designed and sized slabs or cribbing. Where steel plate is used for cribbing, welded or bolted cleats shall be attached to upper surface to prevent float pads from moving horizontally.

For cranes of up to and including 35-ton capacities, wooden cribbing shall be a minimum of four inches (4") in thickness. For cranes over 35-ton capacities and up to 150-ton capacities, cribbing shall be a minimum of eight inches (8") in thickness. For all cranes up to 150-ton capacity, the minimum size of the surface ("footprint") of the cribbing assembly shall be determined by the following formula: the capacity of the crane (in tons) divided by 5 equals the minimum square footage required. Properly sized circular crib pads are acceptable. Side dimensions for rectangular crib pads shall be equal to each other or differ by no more than one foot. For cranes larger than 150-ton capacities, a qualified person shall design the cribbing. "Sandwich"

units of cribbing are allowed as long as the plywood on bottom and on top is at least one inch in thickness.

- 3.6.1.6 For "Pick and Move" operations, the pick shall be made directly in front of the crane with the boom as near vertical as possible. Move at walking speed with a "spotter" in front of the load and another behind the crane. Guy wire cables that secure the load to the body (to prevent lateral force loading of the boom) of the crane shall be required if the grade slope is more than three (3) degrees or the terrain is uneven. Only rubber-tired cranes shall be allowed to perform this operation without a "critical lift" plan and the load must be under fifty percent (50%) of the "on rubber" chart limit.
- 3.6.1.7 Critical Lifts shall include, but not be limited to: (1) Tandem Lifts, (2) Lifts greater than seventy-five (75%) percent of Load Chart, (3) Crane Suspended Personnel Hoists, (4) Non-Conventional Outrigger placements and (5) "Blind" picks and/or placements. All of these events shall require submittal of custom designed plans by qualified persons. The PSC is responsible for review and acceptance prior to planned lifts.
- 3.6.1.8 **Multiple lift operations ("Christmas Treeing") shall not be permitted.**
- 3.6.1.9 **All crane operators on rigs rated for more than five (5) tons of capacity shall submit to a physical examination prior to conducting any work on the Project and, if still on the Project, at least every twelve (12) months thereafter.** The physician's written declaration of fitness shall be submitted to and maintained by the PSC in the Project files.
- 3.6.1.10 Only the designated rigger and/or signal persons shall issue lift instructions to the operator. The only exception shall be an emergency stop signal, which may be delivered by anyone on the Project who knows how to alert the operator.
- 3.6.1.11 All loads lifted more than six feet (6') above ground elevation shall have a tag line attached that is long enough to allow control of load spin without placing any part of the body directly below the load. When "shake out" hooks are used, the load must never be elevated above five feet (5') over the surrounding surface and workers must stay at least five feet (5') horizontally away from the suspended load.
- 3.6.1.12 For any load that may be elevated and the travel path may impact any worker, a means for worker notification must be in place. The crane operator may perform this notification by horn if the load can be seen at all times. If the crane operator may lose sight of the load at any time, notification must be made by a designated individual who can maintain sight of the load. Notification must be accomplished by some means that attracts the attention of all workers and ensures that the workers are not directly below the load being moved.

3.6.1.13 **Any erection or dismantle of a tower crane will only be done while activities are monitored by a crane consultant provided by the Owner. Prior to any operation, the tower crane erection/dismantle contractor shall provide a detailed plan for the work. Details of the plan must include at a minimum, all elements in Exhibit L, and the plan must be provided to the ODR as required. The ODR reserves the right to determine acceptability of the information provided. Submission of this plan in no way relieves the Contractor from ensuring all documentation is provided, reviewed for accuracy based on the planned task(s), ensuring that the work is pre-planned and communicated to all affected workers, all workers are properly trained to perform their tasks, and that all work is done according to the agreed to plan. The PSC is responsible for the review and acceptance for the Contractor.**

3.6.2 Demolition

3.6.2.1 Maintain clearly marked and well-illuminated egress paths at all times.

3.6.2.2 Maintain barricades and signage that isolates impacted areas to prevent entry by other trades and members of the public.

3.6.2.3 Removal of materials and trash from elevated locations must be controlled. Materials, scraps or waste shall never be allowed to free-fall from a height greater than ten feet (10'). Items that may be caught by wind and carried horizontally shall never be allowed to drop freely from any distance. If items are allowed to be dropped freely (unless as indicated previously), a person shall be stationed at the landing elevation at a safe distance to warn others away from the operation, and the landing area shall be surrounded by fence type barricade placed at least six feet (6') outside of the expected landing area. Wall openings that may be located vertically between the material drop point and the expected landing area shall be securely covered and marked from inside. Anything that is to move downward at a distance greater than ten feet (10') or is capable of sailing horizontally shall be contained within a chute or controlled by hoist.

3.6.2.4 Unless the Contract documents clearly call for it, the use of explosives for demolition is prohibited.

3.6.3 Electrical Power

3.6.3.1 Ground Fault Circuit Interruption (GFCI) shall be the primary protection from exposure to electrical current for all workers on the Project. Only exit lighting and medium-high (greater than 240) voltage service will not be GFCI protected.

3.6.3.2 All strings of temporary lights shall be fully lamped and guarded regardless of height, and shall be continuously maintained. PSC shall ensure that illumination levels are periodically monitored and adequate for the expected work activities in those areas.

- 3.6.3.3 All receptacles and switches shall have trim plates installed before they are energized.
 - 3.6.3.4 All power distribution panels shall have full covers installed before primary power is brought into the panel. When energized panels are located in open areas, covers shall be locked except when an authorized electrician is working in the immediate area. When panels are located inside separate rooms or closets, automatic closers and automatically locking hardware shall be installed on doors as soon as equipment is energized, and only authorized persons shall be provided a key. Doors shall not be modified to stay open. Warning signs shall be placed in conspicuous locations. Energized electrical rooms shall not be used for material storage or continuous personal occupancy. Locked electrical room or panel doors will not be considered to meet the requirements of a Lock Out / Tag Out program. The Lock Out / Tag Out program in use must ensure that any affected worker has the ability to confirm equipment being worked on has been de-energized, made safe, and has individual control of the locking device and tag used to control inadvertent startup of the equipment.
 - 3.6.3.5 The employer shall implement and document an overall safety program that directs activities appropriate for the electrical hazards, voltage, energy level, and circuit conditions anticipated.
 - 3.6.3.6 Extension cords used must be a minimum of 12 gauge.
- 3.6.4 Excavations
- 3.6.4.1 **Any and all trenching operations that are four (4) feet or more in depth or could result in any worker's upper body being positioned below grade level shall adhere to the requirements of the UGC.** In addition to UGC requirements, every excavation shall require a preliminary meeting with the ODR to determine historical knowledge of existing utilities. Where applicable, a phone call for utility "locates" shall be completed seventy-two (72) hours in advance. "Potholing" and/or hand digging shall be required within three (3) horizontal feet of "located" centerlines, and in areas where knowledge is lacking.
 - 3.6.4.2 The "toe" of spoil piles that are less than four feet (4') in height shall be at least two feet (2') from the edge of any excavation. Spoil piles greater than four feet (4') in height shall add one foot (1') of distance from the excavation for every additional foot in height. Spoils shall be managed to prevent airborne dust.
 - 3.6.4.3 Trench and/or excavations should be backfilled at the end of each shift as applicable.
 - 3.6.4.3.1 When a trench or excavation cannot be backfilled in the same day that it is created, a highly visible fence type barricade shall be erected at a minimum distance of six feet (6') from all approachable edges. All portable means of access shall be removed at the end of each workday.

- 3.6.4.3.2 Earth ramps that are to be used for walking access shall not exceed twenty percent (20%) in grade slope. Steeper slopes shall be gate controlled for equipment only, and alternate access shall be added for pedestrian traffic.

3.6.5 Fall protection and prevention

- 3.6.5.1 **Any walking/working surface that is equal to or greater than six feet (6') above the surrounding area shall present an unacceptable fall exposure unless it has all edges (side and ends) protected by an attached guardrail system, fall arrest equipment, fall restraint equipment, fall capture netting, or is blocked off by an adjacent wall. An adjacent wall shall be continuous, structurally sound, and at least thirty-nine (39) vertical inches above the walking/working surface, and within eight (8) horizontal inches from the open edge.**

- 3.6.5.2 Any employer that will create a fall exposure equal to or greater than six feet (6') shall submit a detailed plan and set of drawings in advance of the operation to indicate how the exposure shall be addressed. The Contractor shall require the plan to contain either "engineered" or conventional fall protection measures for each and every exposure that involves vertical distances equal to or greater than six feet (6'). Any precautionary measure that would allow greater risk than that afforded by a guardrail system, fall restraint equipment, fall arrest equipment, or fall capture netting shall be prohibited. **The use of a "Monitor" is expressly prohibited.** The recognized exemptions/exceptions are as follows:

- 3.6.5.2.1 Allow work from portable step ladders as long as a "three point" contact is maintained, the ladder is properly positioned, secured from movement, the worker's center of gravity remains between the rails and in front of the feet, and the worker's waist does not extend above the top of the ladder. The height of the worker's feet is limited to twelve feet (12') above the supporting work surface for this exemption/exception.

- 3.6.5.2.2 Allow work from an extension or straight ladder if the ladder is properly positioned, secured from movement, "three point" contact is maintained, the worker's center of gravity remains between the rails and in front of the feet, and the worker's waist does not extend above the top of the ladder. The height of the worker's feet is limited to twelve feet (12') above the supporting work surface for this exemption/exception.

- 3.6.5.2.3 **The use of a warning line system is prohibited unless all other means of fall protection have been demonstrated to be infeasible. If infeasibility is demonstrated to the satisfaction of the PSC and the ODR, work may be performed without fall arrest measures while standing on an elevated walking/working surface only if maintaining a distance of at least fifteen (15) horizontal feet from the edge. The unprotected edge shall be clearly identified by posted signage and a**

warning line erected continuously at a fifteen-foot (15') setback distance.

- 3.6.5.2.4 When work is to be performed from a ladder placed near a guardrail system and the ladder can fall toward the leading edge, the safe distance from an unprotected edge shall increase one foot (1') horizontally for each vertical foot that a worker climbs above the surrounding surface. This requirement shall also apply to a ladder that is being placed beside a protected edge. Any leading edge ("controlled access") zone work shall require fall protection arrangements prior to entry.
- 3.6.5.3 Covers placed over pier holes, and roof or floor openings shall be physically secured and clearly marked with warning message "HOLE COVER - DO NOT REMOVE." Any cover that is too small for legible wording shall be bright orange or red.
- 3.6.5.4 Job built ramps and bridges shall be surfaced with an abrasive (non-skid) material. Ramps shall comply with ADA slope requirements.
- 3.6.5.5 Equipment and work operations of any description shall not be permitted to be performed directly above a worker unless adequate overhead protection is provided prior to commencement of the operation.
- 3.6.5.6 Any tiered contractor that utilizes fall protection equipment in the course of their work shall provide for prompt rescue of a worker in the event of a fall or shall ensure that a worker is able to self – rescue. Specific plans for rescue of workers shall be developed prior to initiating work requiring the use of a personal fall arrest system. The fall protection plan along details for self - rescue as needed shall be submitted to the PSC for review prior to work start.
- 3.6.6 Fire Protection
- 3.6.6.1 All floors that have combustible materials present shall be accessible from ground level by a usable stair system (temporary or permanent). For structures greater than three (3) stories in height, fire sprinkler standpipes shall be completed and charged to within two (2) stories, or thirty (30) vertical feet of all floors containing combustible materials. Siamese connection shall be installed at every level to provide access for fire hoses. All fire extinguishers that are not task-specific shall be adequate in number and description to comply with OSHA declared limits for egress points, floor area and travel distances. In multistory buildings, at least one fire extinguisher rated no less than 2A shall be located adjacent to each stairway on each floor. They shall be situated in highly visible locations mounted at a height to facilitate ease of inspection and retrieval for use. All fire extinguishers shall be inspected monthly. Inspections tags shall be attached to each extinguisher and initialed by the inspector after each inspection.

- 3.6.6.2 All fire extinguishers that are task specific shall be inspected and furnished in advance by the employer that will be conducting the work requiring such firefighting provisions. All work that includes burning, welding, or spark producing of any type shall be defined as “hot work” and shall require the presence of a fire extinguisher, at least one fire watch, and a Hot Work Permit. Fire extinguisher(s) used for “Hot Work” shall be placed within sight of but no more than twenty-five feet (25’) from the perimeter of the task operation and must be of proper size and type for the activity, fully charged, and inspected prior to use. Extinguisher location must be kept clear and accessible at all times during use. Fire extinguishers in use for general project protection shall not be used for this purpose. Refer to WELDING AND BURNING for additional details.
- 3.6.6.3 No more than twenty-five (25) gallons per floor, of flammable or combustible liquids shall be stored in a room outside of an approved storage cabinet.
- 3.6.6.4 Only UL approved metal fuel containers with flame arrestor and self-closing spout shall be allowed on the project.
- 3.6.6.5 Any liquid storage container larger than twenty - five (25) gallons shall be provided with its own secondary containment. Containment must be properly sized and maintained for effectiveness.

3.6.7 Housekeeping

The PSC or PSA shall ensure that the Contractor and all Subcontractors “effectively” clean the Project site continuously throughout each workday. "Effective clean-up" shall daily address all of the following housekeeping issues:

- 3.6.7.1 All construction waste, trash, and debris shall be placed in designated receptacles. Glass bottles shall not be permitted on the Project site.
- 3.6.7.2 Stack (or restack) all whole and scrap materials in locations that shall not obstruct a clear pathway nor create a risk for toppling onto a person passing through the area.
- 3.6.7.3 Place all hoses, cords, cables and wires in locations that prevent them from being damaged by equipment, sharp edges or pinch points and from creating tripping hazards.
- 3.6.7.4 Secure and effectively cover all materials on roofs or elevated levels that may be displaced by wind or damaged by driving rain or standing water.
- 3.6.7.5 Restore all signs, barricades, fire extinguishers, guardrails, gates, etc. to proper locations and sound condition.
- 3.6.7.6 Properly store and secure all flammable and combustible liquids and gases.

- 3.6.7.7 Collect and place all cut-off or waste pieces of rolling stock, as they are created, into waste or scrap containers.
- 3.6.7.8 Live rounds that have been ejected from powder-actuated tools shall be immediately placed in designated containers and properly disposed of as recommended by the manufacturer.
- 3.6.7.9 All puncture and impalement exposures shall be covered or eliminated as soon as they are created. As per ANSI specification, effective covers shall be designed to prevent impalement of a 250-pound body being dropped from a fall of four feet (4’).
- 3.6.7.10 All aisles, exits, and other parts of the means of egress shall be properly maintained and free of stored material and/or waste at all times.

3.6.8 Ladders

- 3.6.8.1 **Until such time that two (2) usable stairways are in place, every elevated platform (slab, deck or work surface) shall have at least two (2) remote (considered to be on opposite ends of the work level) ladders for access/egress when the platform is populated by more than three (3) persons. As the population rises above twenty-five (25), additional means of independent access/egress shall be required. A double-cleated ladder may only serve as one (1) independent means of access/egress.**
- 3.6.8.2 **At the end of each workday, ground access to elevated levels shall be eliminated. This shall be accomplished by removal and storage of all portable and job-built ladders, or installation of a lockable shield that prevents use of the lower rungs.**
- 3.6.8.3 Portable aluminum ladders shall be prohibited.
- 3.6.8.4 Extension ladders, straight ladders and job-built ladders shall be secured from movement at the top and the bottom.
- 3.6.8.5 Physical barricade offset that forces at least one change in walking path direction shall be constructed within a six-foot (6’) radius around the upper access points for any ladder’s step off landing area. If space does not allow this required offset barricade, another type of physical barricade must be provided at the ladder’s step off landing area.
- 3.6.8.6 All elevated landings shall include a rope hoist (manual or motorized) near the ladder’s upper-most access point.
- 3.6.8.7 Minimum acceptable manufactured step or extension ladder that can be used is an ANSI heavy-duty rating Type IA. All ladders must be inspected daily for condition

and set up. All manufacturer installed labels must be maintained in legible condition on all ladders. All ladders must be marked in such a way as to identify the owner.

3.6.9 Medical Assistance and Screening

- 3.6.9.1 The PSC shall maintain a First Aid Log for all treatment administered on the Project (including any that might later escalate). Each SSR shall report and record details daily.
- 3.6.9.2 The PSC or PSA and SSR shall transport or accompany any injured worker for initial off-site medical treatment.
- 3.6.9.3 Drug and Alcohol Screening shall be mandatory for every supervisor and/or worker who sustains or contributes to any incident that involves property damage, worker injury or as directed by the Owner. If impairment or poor judgment appears to be involved in a first aid event, PSC shall direct injured employee to be screened for probable cause.
- 3.6.9.4 **Minimum requirements for drug screening shall at least match the threshold limits for the NIDA 5-panel protocol and alcohol screening shall at least match the Texas DOT vehicle operator's limit for blood alcohol content. Only negative results are acceptable for employment on the Project. Evidence that testing was performed as required shall be by a letter provided by the employer that includes: name of employer and representative, date of testing, name of testing organization, testing criteria that meets or exceeds the above noted levels, name of each worker tested, and results (positive or negative as appropriate).**
- 3.6.9.5 Screening shall be initiated as soon as possible, but not later than two (2) hours after the incident occurrence. No matter where the worker receives medical treatment, a post incident drug and alcohol test MUST occur at the Project assigned clinic. Any worker's refusal to submit to screening shall be treated in the same manner as a "positive" finding. Any worker who withholds notification of an incident for longer than one (1) hour after the alleged event shall be evaluated by the PSC or PSA, and if declared to be negligent shall be permanently removed from the Project.

3.6.10 Motorized Equipment Operation

- 3.6.10.1 Where possible, equipment operator cabs shall be locked during non-working hours. Only equipment operators and direct supervisors shall have access to keys.
- 3.6.10.2 No combustion engine equipment shall be operated in enclosed spaces unless the exhaust is piped to outside air, and "fresh" air is brought into the space to replace the amount being consumed. The PSC shall be responsible for monitoring air quality on the Project when combustible engine equipment is used. This includes generators, welding machines, and compressors as well as mobile equipment.

- 3.6.10.3 For hose and termination fittings on air compressors, "whip checks" shall be used at all connection points. Emergency automatic shut off valves shall be installed on every discharge fitting of all air compressors that are capable of producing air pressure greater than thirty (30) pounds per square inch.
- 3.6.10.4 Any equipment that operates by rotating such that a worker can possibly be exposed to a caught between hazard must have the swing radius barricaded to prevent worker entry.
- 3.6.10.5 Only company vehicles with evidenced company provided insurance are allowed in the construction area while on the project. Parking is only allowed in the Contractor's designated parking area(s).
- 3.6.10.6 Accessories for all mobile equipment (blades, buckets, forks, etc.) shall be placed in the down position, ignition off, parking brake engaged, and keys removed when the equipment is parked and the operator is no longer on the equipment.
- 3.6.10.7 If a forklift, crane, or other such mobile lift and carry equipment is being used in an area where the public may be present or in a congested project area where the operator's view may be obstructed, flaggers/spotters will be required as determined by the PSC or PSA.

3.6.11 Public Protection

- 3.6.11.1 The project boundary perimeter shall be secured from public intrusion by fencing and locked gates.
- 3.6.11.2 "Attractive nuisance" items such as tower cranes, tall ladders, fire escapes, large excavations, etc. shall require additional and separate security measures.
- 3.6.11.3 No visitor or member of the public shall enter a construction area without an authorized escort.
- 3.6.11.4 All visitors to the project must abide by all applicable project safety requirements. Visitors must read and sign the Visitor's General Waiver and Release (Exhibit C) prior to entry to the construction area(s).
- 3.6.11.5 The Contractor shall be authorized to contact campus police to remove anyone who refuses to abide by Contractor directive to leave the construction area. The ODR shall be notified immediately should this occur.

3.6.12 Sanitary Facilities

- 3.6.12.1 The Contractor shall provide at least one (1) toilet facility per twelve (12) workers (separate count per gender) at the Project site; and shall pump, clean and re-supply at

least once per week to maintain sanitary conditions. When average temperatures during daylight hours exceed 85 degrees, pump outs shall occur at least twice per week. When female workers are present at the site, toilets designed and designated for their exclusive use shall be clearly marked. Toilets located in project management office trailers and used by office support staff shall not be considered to meet this requirement unless by written consent of the ODR.

3.6.12.2 On all projects that are four (4) stories in height or greater, sanitary facilities shall be furnished on ground level and every third level (maximum 45 vertical feet).

3.6.12.3 The Contractor shall provide and maintain hand washing and sanitizing facilities sufficient in numbers and locations as to support the toilet facilities indicated in Section 3.6.12.1 and 3.6.12.2.

3.6.12.4 The use of any Owner toilet facility is strictly prohibited unless by written consent of the ODR.

3.6.13 Scaffolding

3.6.13.1 Each ground-supported scaffold shall bear a shift inspection tag (initialed and dated by the competent person for each company that requires use of the scaffold) to indicate the status of the scaffold (green tag means completely safe and red tag means specific precautions required, or not safe/do not use). For suspended scaffold, inspection tags shall also be placed on the outriggers as well as the work platform. The PSC shall purchase and control a universal system to be used by all employers at the Project site. Training with supporting documentation shall be required for all workers on the Project who will climb onto any kind of scaffolding. The PSC shall furnish tags, and ensure that all applicable workers understand the procedure. This requirement shall apply to all scaffolds.

3.6.13.2 Mudsills and surrounding areas at the base of ground-supported scaffolds shall be maintained in a well-dressed and level condition. Scaffold foot plates (or casters) shall be installed on the legs of all ground level frame sections and shall be visible for inspection at all times. Diagonal braces shall be included in every scaffold section as is practically possible. Every walking/working level shall be fully planked and kick-off protection shall be included along open sides and ends. Overhead protection shall be constructed where walk-through passages are allowed. Mudsills shall be at least 2"x12" in one-foot lengths with foot plate centered and nailed in two corners.

3.6.13.3 Brakes on rolling scaffolds shall be secure at all times, except when the scaffold is being moved. Workers shall not be allowed on the platform when a scaffold is being moved. Rolling scaffolds should be used on solid, unobstructed, and flat floor surfaces only.

3.6.13.4 **Workers in any type of aerial lift including man lift or scissor lift shall be provided with a means to be secured (restraint or maximum 6 ft. SRL) to the**

lift so that movement is limited to the floor of an elevated lift. No worker shall be allowed to stand on the toe board or rail of the lift. No lift shall be modified to allow the operator to stand above the floor. No worker shall be allowed to exit an elevated lift.

3.6.13.5 Stilts shall be inspected daily by the equipment user and maintained properly. Surfaces on which stilts will be used must be dry, flat, and free of pits, holes and obstructions such as debris, as well as other slip, trip and fall hazards. When a worker is using stilts in an area where a guardrail system is used for fall protection, the guardrail system must be increased in height by an amount equal to or greater than the height of the stilts being used. **A rigid platform at a height equal to or greater than the height of the stilts shall be used for mounting/dismounting stilts. The platform must be wide and deep enough to sit comfortably, be stable, and be secured from movement while in use. The platform must be kept clear, accessible, and within the immediate work area (considered to be within 75 ft.) while stilts are in use. Stepladders or makeshift platforms cannot be used for this requirement.**

3.6.14 Stairs

3.6.14.1 Properly designed and built stair and landing units shall be placed at access doors for every Project office and storage trailer prior to use. Per ANSI requirements, the landing outside each door of any office trailer shall be no greater than one quarter inch (1/4") below the threshold and the unobstructed (standing) area outside the swing radius shall be no less than twenty-two inches (22"). Fire and Life Safety Code (NFPA) and ADA requirements shall also be satisfied as they apply. Ramps or connecting decks may be installed to satisfy this requirement.

3.6.14.2 For incomplete permanent stair sections, at least the bottom four (4) risers and upper entry points for each floor shall be physically blocked with a hard barricade and marked "INCOMPLETE – DO NOT USE." Until a complete section is made acceptable for general use, the barricades and signs for that section shall be maintained. Once permanent stairs are put into service for general use, no less than two (2) stairs must be maintained as open and accessible from the uppermost floor to ground level at all times. To be considered usable, all treads and landings must be filled to the top of the pan and handrails must be in place. If any previously available stair(s) will be blocked during the workday, all impacted workers must be notified and the alternate means of access/egress communicated prior to that day's work start.

3.6.15 Project Service Water

3.6.15.1 Potable Water: Potable water shall comply with city and community health requirements.

3.6.15.2 Non-potable Water: Water storage containers, hose bibs and faucets shall be posted in English and Spanish "DANGER – DO NOT DRINK or WASH."

3.6.16 Welding and Burning

- 3.6.16.1 Splices, taps, welds and/or burning operations that may produce sparks, slag or hot scraps shall require “Hot-Work” or “Burn” Permits (daily or per shift). “Burn Permit” shall be issued by the PSC. The SSR shall submit completed permit in advance of the work to the PSC for acceptance. One copy of the accepted permit shall be posted by the SSR in the immediate area of the operation. At the conclusion of the work and successful completion of the smolder/re-kindle watch, a copy of the expended permit shall be signed off and returned to and filed by the PSC. If the campus Environmental Health and Safety group wishes to be involved in the process (provision of permit and/or pre-inspection of the permit space), the Contractor shall accommodate these wishes. The PSC will also issue work specific permit daily or per shift. The PSC shall ensure that all Hot Work will be provided with at least a fire watcher(s), fire extinguisher(s), and proper spark, slag, or hot scrap containment measures. If the work produces intense light, permit shall also contain requirement for screens to protect others from flash burns.
- 3.6.16.2 Oxygen and fuel gas cylinders shall not be stored together, including on bottle carts, but shall be separated by at least twenty (20) feet and properly secured from movement. At the end of any cutting operation and/or any shift, bottles must be removed from carts. Hoses and gauges shall be removed and caps restored onto cylinders.
- 3.6.16.3 Anti-flashback arrestors shall be installed at the pressure regulator gauges of all Oxy-Acetylene cutting rigs, even if the torch is equipped with a built-in arrestor.
- 3.6.16.4 Fire watcher(s) shall be posted at every operation that produces sparks, flames or sufficient heat to create an ignition or to fall onto another level. If multiple activities are no more than twenty (20) feet apart and all activities can be seen at all times, a single fire watch can be utilized. This allowance must be noted on the Hot Work permit. All fire watchers shall be trained in the use of extinguishers, shall keep other people from entering exposure areas, and shall not be assigned other duties until the rekindling possibility ("smolder/re-kindle watch") is over. When sparks, slag, or fire cannot be controlled at the source and may fall to a different level, a separate fire watch shall monitor each level directly below the work (including exterior locations).
- 3.6.16.5 Heater boxes for welding electrodes shall have a manufacturer's label that certifies the purpose of the unit. Job-built heaters shall be prohibited.
- 3.6.16.6 The unused stubs of welding electrodes (“rod butts”) shall be collected and placed in proper disposal containers (i.e. metal bucket with sand or water) as soon as each one is expended. Whenever operation is idle, electrode shall be removed from stinger.
- 3.6.16.7 Welding operations shall not be allowed to present an opportunity for flash burn exposures to the eyes of any workers in the vicinity. All welding operations shall

provide appropriate screening measures, erected in advance to contain the high energy light.

3.7 REQUEST FOR SAFETY VARIANCE

If the Project conditions present a situation that will not allow compliance with any portion of this Section, the Contractor shall submit a Request for Safety Variance (EXHIBIT I) to the ODR. The Request for Safety Variance must provide sufficient detail(s) regarding the action(s) to be taken that will provide a measure of safety that is equal to or exceeds the stated requirement. Until the variance is approved and signed by the ODR, compliance with this Section is required.

EXHIBIT Attachments:

- EXHIBIT A Anticipated Construction Project Hazards – Checklist submittal
- EXHIBIT B Hot Work Burning/Welding Permit – Project file document
- EXHIBIT C Visitor’s General Waiver and Release – Contractor submittal
- EXHIBIT D Project Safety Orientation Checklist – Project file document
- EXHIBIT E Subcontractor Safety Representatives Weekly Meeting Agenda - Template
- EXHIBIT F Quarterly Equipment Inspection Report – Project file document
- EXHIBIT G Worker Guide for Reporting Injury - Handout
- EXHIBIT H Supervisor Guide for Management of Worker Injury - Handout
- EXHIBIT I Request for Safety Variance – Contractor submittal
- EXHIBIT J Root Cause Analysis
- EXHIBIT K Incident Notification Flow Chart
- EXHIBIT L Tower Crane Assembly/Disassembly Documentation
- EXHIBIT M Job Hazard Analysis Form (Mandatory)
- EXHIBIT N Safety Specification 01 35 23 Contractor Acknowledgement Statement

END OF SECTION 01 35 23

EXHIBIT A
CONTRACTOR SUBMITTAL TO OWNER – CHECKLIST
The University of Texas System – Construction Project Safety
ANTICIPATED CONSTRUCTION PROJECT HAZARDS

CIP (Owner's Project) #		Project Name	Date
No	Yes	Issue	Timing for appearances & ID for Subcontractor JH/SA's
General Health Exposures			
		Noise, Illumination, Lasers and X-ray	
		Dusts, Mists, Vapors, Gases	
		Chemical exposures	
		Proximity to public and/or traffic	
		Existing geography/ extreme weather	
Electrical Exposures			
		Overhead power lines in area	
		High Voltage (≥ 600 volts)	
		Hot taps and/or Double fed circuits	
Excavations			
		Tunnels and/or Jack and Bore	
		Maximum estimated trench depth	
		Maximum estimated pier sizes	
		Existing underground services	
		Proximity to streets or buildings	
Elevated Fall Exposures			
		Excavations and piers	
		Structural erection (steel/precast)	
		Building exterior	
		Stairwell/ Chase/Elevator Shaft	

		Roof (note steep or low slope)	
--	--	--------------------------------	--

Cranes/ Hoists/ Derricks			
---------------------------------	--	--	--

		Pier Drilling/ Pile Driving	
		Exterior Hoists (Elevators)	
		Mobile Cranes (track and rubber tire)	
		Tower Cranes	
		Critical lifts	

Tools and Equipment			
----------------------------	--	--	--

		Powder Actuated	
		Pneumatics or High Torque power tools	
		Generators and Compressors	

Motor-Driven Equipment			
-------------------------------	--	--	--

		Earth moving equipment	
		Lift Platforms (articulating and/or scissor)	
		Industrial trucks (fork lifts)	
		Bulk fuel storage area	

Demolition			
-------------------	--	--	--

		Structural, Explosive or Mechanical	
		Jackhammers and power cutting	

Scaffolding			
--------------------	--	--	--

		Ground supported (static and/or motorized)	
		Suspended	

Welding and Burning			
----------------------------	--	--	--

		Types and Locations	
--	--	---------------------	--

Confined Space			
-----------------------	--	--	--

		Permit required and/or not required	
--	--	-------------------------------------	--

EXHIBIT B
CONTRACTOR DECISION MATRIX – GUIDELINE
The University of Texas System – Construction Project Safety
**HOT WORK (BURNING/WELDING) PERMIT
 (ONE COPY MUST BE POSTED IN THE VICINITY OF THE WORK)**

CIP Number		Request Date:	
UT Campus / Institution			
Project Name			
Requesting Company			
Responsible Supervisor			
Work Location			
General Description of Work Tasks			

ISSUES AND/OR PREVENTION MEASURES	DESCRIPTION
Dedicated Fire Extinguisher(s)	
Special Suppression Equipment	
Fire Blankets/Equipment Shielding	
Flash Burn (Eye Safety) Screening	
Fire Watch Position(s)	
Existing Sprinklers Disabled	
OTHER CONSIDERATIONS:	

NOTES:

1. All permits are good for one (1) shift only.
2. Unless a specific task requires a **LONGER** time period, fire watch positions must also conduct a smolder-rekindle watch for at least THIRTY (30) MINUTES after the burning/welding operation is completed.

3. If the work moves from one area to another during a single shift, the permit must accompany the move and all task areas must be identified on the permit.
4. After the work is completed, the permit must be initialed by the RESPONSIBLE SUPERVISOR (below) and a copy must then be forwarded to the Prime (Controlling) Contractor within one (1) work day.

If unexpected events during the work led to modified plan, place initials in appropriate box: NO YES
If **YES**, describe the unexpected events and the subsequent actions.

**Visitor's General Waiver and Release
The University of Texas System (Owner)**

Visitor Name (Printed): _____

Company / Group Affiliation: _____

Project Name: _____

Project Number: _____ Campus: _____

General Contractor: _____

Project Safety Coordinator Name (Printed): _____

On behalf of The University of Texas (Owner) and the General Contractor, we welcome you to the project. Construction projects can be dangerous and hazardous to employees and visitors alike. Upon entering the site, you must exercise extra care to adhere to safety protocols and instructions from knowledgeable construction professionals.

Initials _____ I acknowledge that I will observe and follow all safety procedures, including any warning signs or safety instructions posted on or about the premises. In addition, I acknowledge that proper safety vests, hard hats and safety glasses have been provided to me for my visit. I am wearing closed toed shoes that the Project Safety Coordinator has acknowledged will be appropriate for my visitation.

Initials _____ I hereby waive, release and hold harmless, as well as forever discharge, The University of Texas System, the General Contractor and all subcontractors, their agents and employees from all claims which I, or my heirs, executors or administrators shall or may have, because of bodily injury or death to me or damage to my property resulting from any act or omission of the Released Parties. I AM NOT AGREEING, HOWEVER, TO RELEASE THE RELEASED PARTIES FROM GROSS NEGLIGENCE.

Initials: _____ I hereby agree to indemnify, defend and hold harmless the Released Parties for any bodily injury, death or damage to other persons or property caused by my acts or omissions while visiting the project.

Initials: _____ I, the undersigned, acknowledge that I (1) have requested permission from the Owner and General Contractor to visit the Project Site; 2) have executed this Waiver and Release as a condition of and in consideration for being permitted by Owner and General Contractor to visit the project Site; and 3) agree to exercise extreme care while on the Project Site and to comply with all safety rules and requirements of the Owner and General Contractor.

Visitor Signature: _____ Date: _____

Project Safety Coordinator Signature: _____

EXHIBIT D	CONTRACTOR CHECKLIST – TRAINING DOCUMENT
------------------	---

The University of Texas System – Construction Project Safety

PROJECT SAFETY ORIENTATION	
UTH Project #:	Date of Safety Orientation Training:
UTH Project Name:	
Trainer's Name:	
Contractor/Employer's Company Name:	

INSTRUCTIONS: Place a  mark in the box to the right of each topic as it is discussed.

1-	Review General Purpose of Rules		7-	Daily Issues	
a.	Do NOT work alone – stay in contact	<input type="checkbox"/>	a	Housekeeping	<input type="checkbox"/>
2-	Personal Protective Equipment (PPE)	<input type="checkbox"/>	ITEM	Slippery surfaces and Trip hazards	<input type="checkbox"/>
	Purpose, use, storage and care of:	<input type="checkbox"/>	ITEM	Visual obstructions to emergency equipment	<input type="checkbox"/>
a	Safety Helmets (Hard Hats)	<input type="checkbox"/>	ITEM	Blocked Exit paths	<input type="checkbox"/>
b	Basic Eye Protection	<input type="checkbox"/>	ITEM	Emergency Roadways	<input type="checkbox"/>
c	Additional Eye/Face Protection	<input type="checkbox"/>	ITEM	Trash = Vermin/Fire hazards	<input type="checkbox"/>
d	Feet/Hands/Clothing Protection	<input type="checkbox"/>	ITEM	Puncture/Impalement hazards	<input type="checkbox"/>
e	Respiratory Protection	<input type="checkbox"/>	ITEM	Unstable Stacks of materials	<input type="checkbox"/>
f	Hearing Protection	<input type="checkbox"/>	b	Manual Lifting	<input type="checkbox"/>
g	Fall Protection	<input type="checkbox"/>	c	Ladders and Stairs	<input type="checkbox"/>
h	Special Protection issues	<input type="checkbox"/>	d	Scaffolding (frame and suspended)	<input type="checkbox"/>
3-	Hazard Communication (aka Right to Know)	<input type="checkbox"/>	e	Tools and Portable equipment	<input type="checkbox"/>
a	General Plan	<input type="checkbox"/>	f	GFCI/Electrical power	<input type="checkbox"/>
b	Major Chemical hazards on-site:	<input type="checkbox"/>	g	Surface and ground conditions	<input type="checkbox"/>
NAME		<input type="checkbox"/>	h	Overhead exposures	<input type="checkbox"/>
NAME		<input type="checkbox"/>	8-	Motorized Equipment Operations	<input type="checkbox"/>
NAME		<input type="checkbox"/>	a	Mobile equipment (uses and alarms)	<input type="checkbox"/>
NAME		<input type="checkbox"/>	b	Crane and Rigging Operations	<input type="checkbox"/>
c	Hazard Labels	<input type="checkbox"/>	c	Lift platform equipment	<input type="checkbox"/>
d	Safety Data Sheet (SDS)	<input type="checkbox"/>	d	Hoists/ Exterior Elevators	<input type="checkbox"/>
e	Location of SDS	<input type="checkbox"/>	e	Company/ Personal Vehicles	<input type="checkbox"/>

	f	Safe Task Training requirements		9-	Special Operations (with and w/out permit)	
4-	Emergency Equipment (location and use)			a	Excavations	
	a	First Aid Station and AED		b	Concrete pour and place	
	b	Fire Extinguisher		c	Steel and Precast erection	
	c	Eye Wash/Shower Stations		d	Decking and roofing	
5-	Emergency Procedures			e	Lock/Tag out of Energized Systems	
	a	Medical/ Injury incident		f	Hot work and Burn Permits	
	b	Fire incident		g	Scaffold erection/dismantle and use	
	c	Weather/ Evacuate		h	Critical shutdown	
	d	Violence, Protest, Spill, Explosion		10-	Miscellaneous Issues	
6-	Incident Notification/Reporting			a	Parking, Smoking, Harassment	
	a	Tell Supervisor Immediately		b	Signs, Barricades, Handrails	
	b	Help –OR- stay out of the way		c	Traffic, Pedestrians, Neighbors	
	c	Give a statement of facts		d	Drugs and Alcohol	
	d	Assist investigation		e	Meetings, Badges, Incentives	
	e	Report Unsafe acts and conditions		f	Enforcement	

I understand that this training is designed to help me make safe decisions and act to reduce risks.

 Employee Name (print)

 Employee Signature

EXHIBIT E

CONTRACTOR TEMPLATE – FILE DOCUMENT

The University of Texas System – Construction Project Safety

SAFETY REPRESENTATIVES WEEKLY MEETING AGENDA

- Sign in and introduction of any new Subcontractor Safety Representatives
- Read minutes from last meeting and vote final adjustments before filing into record

Past (Old Business):

1. Discuss investigations (findings and conclusions) from recent past incidents.
2. If the Project has a safety committee, have someone from the committee report the safety conditions and behaviors noted in the past week.
3. Review safety issues/conditions identified during Project Safety Coordinator's weekly safety inspection or third-party inspection.
4. Discuss any pending claims (worker injury or general liability). Review claims handling procedures.
5. Discuss trends identified regarding claims or safety performance.

Present (Current and New Business):

6. Review the activities for the week ahead. Identify particular safety concerns and issues. Develop actions to control identified hazards.
7. Review any SDS for potential exposure warnings that pertain to upcoming operations.
8. Review specific PSMP elements and/or requirements.
9. Safety suggestions.
10. Open forum for general Q and A.
11. Announcements
 - Subcontracts that are concluding – need final look at their areas
 - Upcoming safety recognition events
 - Upcoming training opportunities
 - Upcoming professional safety seminars or workshops
 - Names of workers who are not permitted to return to Project
 - Time and date of next meeting
 - Next week's mandatory topic for the Weekly Tool Box talk

EXHIBIT F SUBCONTRACTOR SUBMITTAL – FILE DOCUMENT

The University of Texas System – Construction Project Safety

QUARTERLY EQUIPMENT INSPECTION REPORT

Quarterly Color Codes:	(1 st) White	(2 nd) Green	(3 rd) Red	(4 th) Orange
Project Number	Date of Report			
Project Name				
Contractor				
Employer Name				
Inspector's Name				

INSTRUCTIONS:	Insulation intact and cords undamaged	Clean, no electrical shorts, good polarity	Labels in place and legible	All parts present and undamaged	No excessive wear or corrosion	No deformity or sign of excessive strain	Safety feature(s) intact and working	Warning alarms operating properly
1. Use one line to identify each type of portable equipment on Project.								
2. Use a "check" mark to indicate pertinent categories for each line item.								
3. Use an "N/A" mark to indicate non-applicable categories for each line item.								
4. Use "Qty." column to indicate total number for each item inspected.								
5. Use "Comments" area to describe items removed for repair and/or discarded.								
6. Complete this process within final fourteen (14) calendar days of each quarter.								
7. Items that enter or return to Project during quarter must first be re-inspected.								

Portable Equipment Items	Qty.	Inspection Categories						

Comments:

I certify that all of the portable items on this Project at the beginning of this quarter have been inspected and certified or removed from service.

_____ Signature of Inspector _____ Date of Report _____

Distribution:

Employer's Project file

Contractor's Project file

EXHIBIT G

CONTRACTOR INFORMATION – WORKER HANDOUT

The University of Texas System – Construction Project Safety

WORKER GUIDE FOR REPORTING INJURY

- ❖ **WORKERS MUST IMMEDIATELY REPORT** all injuries (no matter how minor) to a supervisor.
- ❖ The supervisor will report the incident to the Contractor and take care of all paperwork.
- ❖ The worker's SSR will drive the injured employee to the clinic to guarantee safe transport and to secure swift and complete medical attention.
- ❖ The doctor may prescribe written "orders" for medical restrictions. The supervisor must then assign temporary duties that fit the restrictions ("Light Duty"). This guarantees the worker a full paycheck while the injury heals.
- ❖ The worker's SSR will drive the injured worker back to the Project and make arrangements with the employer to get the worker and personal vehicle home by a safe method.
- ❖ Injured employees must follow the doctor's "orders" and comply with work restrictions – **at home and at work**. Employers must allow reasonable times for visits to the doctor and to therapy sessions. Normally, sessions can be scheduled during non-work hours.
- ❖ The insurance company may contact the injured employee to discover how the doctor and the employer are planning to treat the injury and the recovery. Injured workers should share any personal details that might help the agent understand the situation. If anything needs to be changed in order to help the recovery process, the agent will contact the proper people to make it happen.
- ❖ The insurance company will pay the medical bills for injuries on this Project. Workers should never pay any medical bills for an injury that is related to work. If there are any questions, talk to a supervisor and/or the Project Safety Coordinator for the Contractor.

SPECIAL WARNING TO USERS AND ABUSERS (of alcohol and other controlled substances):

No matter where a worker receives medical care, the treatment will include a drug and alcohol test. Workers who are injured as a result of impairment from alcohol or non-prescribed drugs will

lose the guarantee that all medical treatment will be covered by insurance. Also, they will not be allowed to return to work on any UT System Project.

EXHIBIT H CONTRACTOR INFORMATION – SUPERVISOR HANDOUT

The University of Texas System – Construction Project Safety

SUPERVISOR GUIDE FOR MANAGEMENT OF WORKER INJURY

1. Workers must **IMMEDIATELY REPORT** all injuries (no matter how minor they appear at the time of the incident) to a supervisor (foreman, general foreman, superintendent, etc.).
2. The supervisor must **IMMEDIATELY REPORT** any injury to the Contractor’s Project Superintendent or Safety Coordinator. Improper and/or late reporting of injuries will result in Owner directed recovery charges as described in the Contract.
3. The supervisor must then escort the injured employee to the Contractor’s Project office (**except when the injury requires an ambulance or emergency response**).
4. The Contractor’s Project Safety Coordinator (PSC) shall retrieve 5 documents from the Project Safety Files as follows:
 - a. The form (Authorization for Medical Treatment) that guarantees quickest medical response at the clinic
 - b. A map that shows the best route to the clinic
 - c. A copy of the Return to Work Policy from the employer of the injured worker
 - d. A “First Report of Injury” form to furnish the insurance company with the necessary information to start a claim and pay medical bills
 - e. A “Bona Fide Offer of Employment” form to guarantee suitable employment for medically restricted workers
5. The worker’s SSR will drive the injured employee to the clinic to guarantee safe transport and present the “Authorization to Treat” form to obtain swift response. This form will also notify the clinic that a test for drugs and alcohol is required. If the injured worker is transported elsewhere, the Contractor shall also notify the insurer. The supervisor shall also be at the clinic to respond to questions from the physician.
6. After the doctor has completed the examination and all required medical care, the worker’s SSR and the worker shall meet with the doctor to accomplish three objectives:
 - a. Review the injury and discover the need for any additional medical assistance.
 - b. Discuss suitable Return to Work positions to accommodate any medical restrictions.
 - c. Present the worker with a “Bona Fide Offer of Employment” form to guarantee continuing employment and to guarantee work tasks that will not exceed prescribed medical restrictions.
7. The worker’s SSR shall then drive the worker back to the Project and shall make suitable arrangements to get the worker and personal vehicle home at the end of the day. If the doctor has written a prescription that contains orders for medical restrictions, the worker must be assigned to (“Light Duty”) tasks that meet the restrictions. This presents a “win-win” for all involved as follows:
 - a. The injured worker will continue to draw his/her full paycheck.
 - b. The employer will be able to keep its insurance rating as competitive as possible.
 - c. The insurance provider will be able to keep the costs of medical claims as low as possible.
8. The SSR must promote three issues to quickly and completely restore health:
 - a. Maintain awareness of medical restrictions, and assign work tasks that do not violate the restrictions.
 - b. When contacted by the insurance agent, be candid and share any information that may expedite the physical recovery of the injured worker.
 - c. Allow reasonable times for physical therapy (or other medical treatment) and maintain contact with worker.
9. **Zurich** is the insurance company that will pay the medical bills. The Contractor’s Project Safety Coordinator will have the contact information to file the required insurance claim.

Printed Name

Request reviewed by UTH Resident Construction Manager

Signature

*Note: This variance as reviewed is understood to be for this scope of work and this project only. It is further understood that this variance is not portable as it relates to any other UTH Project.

Cc: UTH Safety Analyst - Austin

EXHIBIT J **ROOT CAUSE ANALYSIS FORM**

Root Cause Analysis

UTH Project Name _____

Name of Incident _____

UTH Project Number _____

Date of Incident _____

Employee Injury? No Yes

Date of RCA _____

Contractor _____

If yes, list employee name _____

If revising, date of revision _____ Revision No. _____

Subcontractor (if applicable) _____

This RCA is due to:

- Injury, Level "A" Safety Deficiency, Property Damage, Other Incidents as directed by the Owner

Identify all underlying contributing factors to reduce potential for recurrence of same type incident. Remember:

- ✓ Worker's actions made sense to that person at the time (circumstances & perceptions)
- ✓ Understand the thought process behind the decisions that were made at the time
- ✓ Look beyond the individuals involved to uncover systemic contributing risk factors ✓ Break the blame cycle (culture must value honest reporting - learning organization) ✓ Find error precursors & flawed or missing defenses or processes that led to incident

The Root Cause Analysis investigation should thoroughly address these questions:

1. Was the incident controlled and limited so that all workers and the project were made safe post - incident? What was done?
2. Explain what happened (facts and circumstances) that resulted in the incident.
3. Are there other work areas or tasks where this type of incident could occur again?
4. If worker's actions contributed to the incident, why did the worker feel this was the best course of action at the time?
5. What processes were in place to prevent the incident? Identify processes that failed.
6. Is there any other information that should be known that is relevant to this incident?
7. What processes could have been implemented or improved that might have prevented this incident?
8. What processes will be improved or implemented to reduce risk of recurrence? When will these new processes be in place?

FOR OFPC USE ONLYLevel Fire Alarm First Aid Level A Near miss Property Damage Recordable SWPP OtherIncident Caught between Electrical Equipment handling Fall Fall protection Foreign bodyType: Haz mat Heat exhaustion Ladder Material Handling Puncture Security Slip/trip SWPP
 Tool handling Worn Equipment OtherInjury N/A Blunt trauma Chemical burn Contusion Cramps Crushing Dust in eyeType: Fall Flash burn Heat exhaustion Insulation in eye Knee blood blister Laceration Laceration & shock
 Other Puncture Shock Sprain Strain

EXHIBIT K
INCIDENT NOTIFICATION FLOW CHART

NOTE: if calling to report a **serious** incident and someone in the calling chain is unavailable, leave a message, but then jump to the next in the chain to ensure notification is made timely. For example, if contractor cannot reach the PM, contact SPM; SPM would then make the calls for the PM.

NOTE 2: A **serious** incident report will include status of the injured person and follow up until stabilized or back on the job at work.

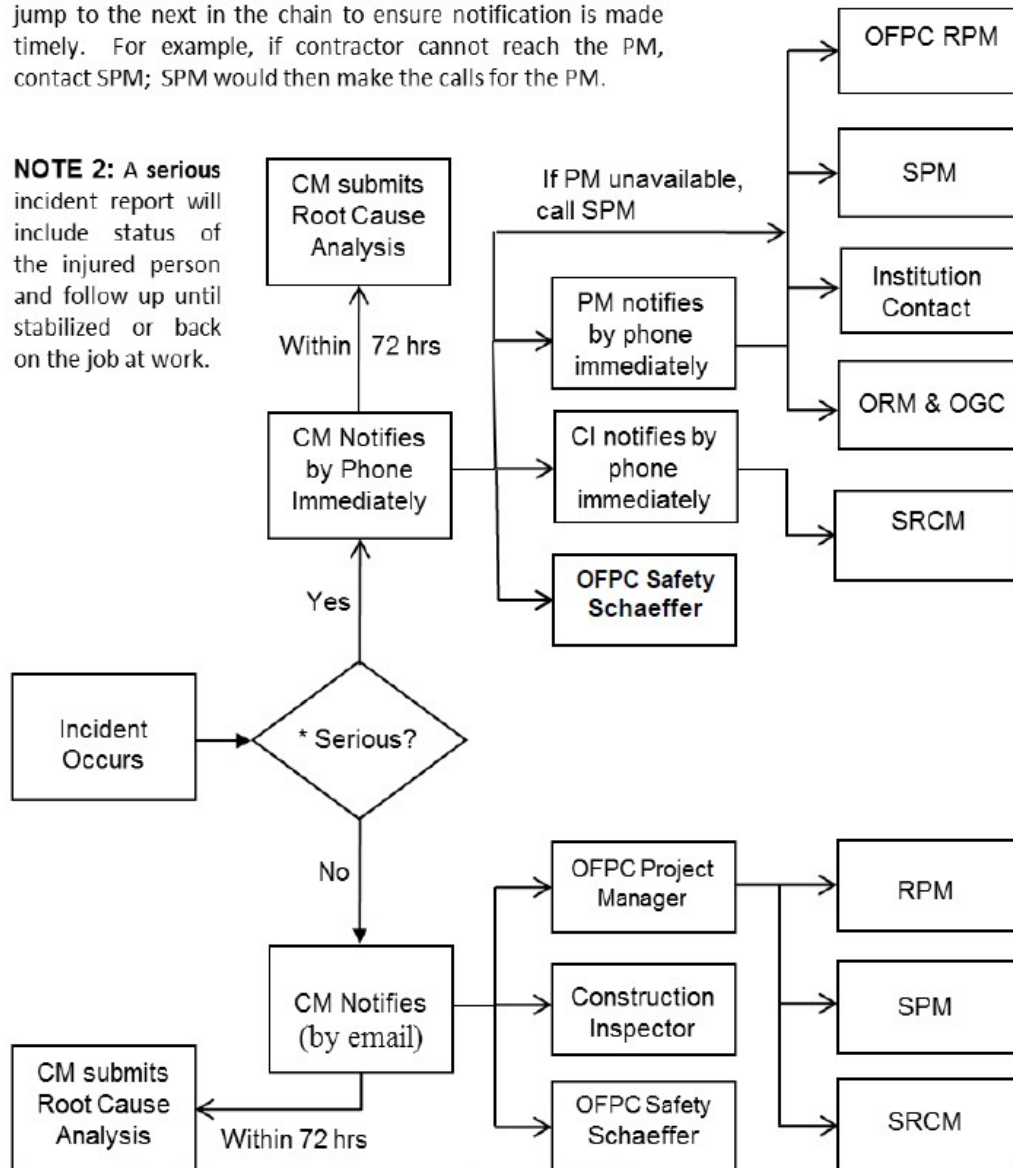

* An incident is considered serious if any of the following occur:

- EMS/Ambulance responds
- hospitalization is involved
- Life threatening or potentially life threatening
- Involves more than one employee injured

EXHIBIT L TOWER CRANE ERECTION / DISMANTLE DOCUMENTATION

The University of Texas System – Construction Project Safety

**REQUIRED INFORMATION TO BE SUBMITTED AND REVIEWED PRIOR TO ANY
TOWER CRANE ASSEMBLY OR DISASSEMBLY OPERATION**

The plan will need to be submitted for review by the Owner at least two weeks prior to the date of the planned erection or dismantle. UTH will be providing a third-party consultant during the erection or dismantle process. No work will begin until all plan elements noted below have been submitted and reviewed for acceptance. The plan must include at a minimum:

1. Annual inspection of all assist cranes that will be utilized to erect or dismantle the tower crane.
2. Operator's nationally recognized certification(s) and supporting training documentation for all make and model of cranes that will be used. Operator's annual physical.
3. Qualifications (with supporting training documentation) for the Erection/Dismantle Director and all crew members, riggers and signal persons. Training documentation must include organization and person(s) that conducted the training, material covered in the training, time spent on each training element, and details to the evaluation process used to verify worker understanding of training. This may be through testing and/or demonstration of skills. Rigging can only be performed by persons who possess documentation of completion from a training program that carries recognized accreditation.
4. Verification of soil conditions for all anticipated mobile crane positions. Detailed plan with map for the location(s) of the assist crane(s) and associated hazards in close proximity to those locations. Plan to control identified hazards.
5. Training documents for all crew members for their assigned task(s). A letter indicating positions with no supporting documentation is not acceptable. Fall protection training must be included. See # 3 for the required training documentation.
6. Details for work stoppage due to high wind speed or other inclement weather conditions. The actual shutdown procedure, including who is responsible for shutdown determination and how it will be communicated to all affected workers.
7. Copy of the manufacturer's equipment manual for review for the make and model of tower crane that will be erected or dismantled.
8. Structural information regarding the tower crane base pad (prior to erection).
9. Details on sequencing for sectional assembly and bolting (including torque) (prior to assembly), details on sequencing for sectional disassembly with bolt removal procedure (prior to dismantle) and rigging procedure with verifications. Cannot indicate that plan will follow manufacturer's equipment manual.

10. Documentation showing that each worker has been drug/alcohol tested within two (2) weeks prior to work start on the project. Negative result per worker is needed for entry.
11. Prior to the assembly of a tower crane, the General Contractor will need to develop a High Angle Rescue Plan. The intent of this plan is to be able to effectively remove an individual from the horizontal portion of the crane in the event of an emergency prior to assembly and during use of tower crane.

REMINDER - this information submission in no way removes **the General Contractor's safety professionals and project management team** from the obligation of ensuring all documentation is provided, reviewed for adequacy based on the planned task(s), ensuring that the work is pre-planned and communicated to all affected workers, all workers are properly trained to perform their individual tasks, and that all work is done according to the agreed upon plan and the manufacturer's requirements

EXHIBIT M
JOB HAZARD ANALYSIS FORM (MANDATORY)

Daily Job Hazard Analysis

This JHA is valid only for the work and date specified. This JHA shall be posted at the immediate work area while the work is ongoing. If the noted conditions change, the JHA shall be re-evaluated to incorporate changes and reissued immediately. Any emergency or incident automatically invalidates this JHA. When this JHA expires, it must be returned to the PSC/PSA for record purposes.

Project Name and Number		Date and Time	
Company Name		Supervisor	

Description of work to be performed:

A. Are Permits Required? Are they displayed and properly signed by the PSC/PSA?

Hot Work	Y	N		Confined Space	Y	N	
Lockout/Tag-out	Y	N		Roadway Traffic	Y	N	
Excavation	Y	N		Other (specify)			

B. Atmospheric Monitoring

Oxygen Concentration	Y	N		Reading	
Combustible Gas/Flammable Vapors	Y	N		Reading	
Hazardous/Toxic Gas	Y	N		Reading	
Are concentration levels safe?	Y	N			

C. THINK about the work you and your crews will be doing today. Place a Y for Yes or N for No next to each element. All elements identified with a Y or Yes must be addressed in Section D.

C.1 Specialized Operations

	Confined Space	A-Frame Ladders
	Aerial Man-lifts	Extension Ladders
	Lockout/Tagout	Scissor Lifts
	Excavations	Opening /Isolation of equipment
	Trenches	Loading/Un-loading >50lbs
	Motonized Equipment	Work on live equipment
	Ground Supported Scaffold	Welding
	Suspended Scaffold	Burning/Cutting operations
	Mobile/Rubber Tire Crane	Work at Heights >6'
	Tower Crane	

C.2 Hazards

Airborne Particulates	Falls	Public Traffic (vehicle/Foot)
Body Stress (hot/cold)	Slip/Trip Hazards	Repetitive Motion
Lighting	Pinch Points	Lifting
Noise	Electric Shock	Material Handling
Radiation	Sharp Objects	Work of Others (specify)
Chemical Exposure (skin/eyes/inhalation)	Thermal Burns	
Flammable Materials	Housekeeping	
Overhead Work	Obstructed View	Other Hazards (specify)
Motorized Equipment	Awkward Positioning	
Access/Egress Paths	Insects/Animals	
Floor Cut-outs	Walking Surfaces	

C.3 Hazard Controls
C.4 Proper PPE

Hazard Assessment	Walking/working surfaces clear and unobstructed	Protective Suits
Pre-task Planning	Proper storage of material and equipment	Hard Hats
Worker Training	Equipment warning/safety devices operational	Safety Glasses
Equipment Selection	Proper lifting./placement/securing of material	Face Shield/Goggles
Equipment Inspection	Fall protection in place/inspected/maintained	Traffic Safety Clothing
Permits developed and reviewed	Housekeeping maintained daily and verified	Fall Protection
Work area verification of conditions	Fire protection measures in place	Hearing Protection
Review of As-builts	Equipment grounded/bonded	Gloves
Utility owners contacted	Flash burns shielded	Respirator
Utilities located and confirmed	Spark containment	Foot Protection
Equipment operators qualified	Flow able material contained	Other (specify)
Equipment training documented and on-hand	Emergency response in place and communicated	
Atmospheric Testing	Barricades/covers/signs in place and secure	
Live equipment isolated? (list equipment below)	Stand-by persons (specify name and task below)	
Competent Person (print name)	Spotter/Flagger/Traffic Control (print name and task)	

D. This portion of this JHA is to be completed by the supervisor with input from crew members. Once complete this JHA must be reviewed with all affected crew members or when conditions change.

Work Activities based on C.1 _____

Possible Hazards base on C.2 _____

Controls to Address Hazards based on C.3 _____



The University of Texas
Health Science Center at Houston

C.5 Emergency Response			
Fire Extinguishers located at?		Report Emergencies to? (name & number)	
SDS located at?		(name & number)	
Eye Wash Station located at		Emergency alarm sounds like?	
First-aid/AED located at?		Muster Point is located at?	

E.	Crew Printed Name	Signature	Badge #	Crew Printed Name	Signature	Badge #
1.				11.		
2.				12.		
3.				13.		
4.				14.		
5.				15.		
6.				16.		
7.				17.		
8.				18.		
9.				19.		
10.				20.		

F. JHA developed and communicated by;		Daily JHA reviewed by (PSC/PSA):	
Printed Name	Signature	Printed Name	Signature
Date	Time	Date	Time

**SAFETY SPECIFICATION 01 35 23
CONTRACTOR ACKNOWLEDGEMENT STATEMENT**

Project: _____

Project No: _____

By executing this document as an authorized representative of the referenced Company identified below, I acknowledge and confirm that I have read and understand the contents of the UTS Safety Specification 01 35 23 in its entirety. I also recognize and acknowledge that the obligation to protect safety and health is not limited to the requirements of UTS Safety Specification 01 35 23 only, but also includes all applicable rules, regulations, and guidelines necessary to provide a safe and healthful working environment for all employers and employees on the project. The Company will comply with all applicable safety requirements.

The Company will further communicate the requirements of the UTS Safety Specifications 01 35 23 and other applicable safety rules, regulations and guidelines to all tiered Subcontractors that will perform work on the Project and obtain and submit to the Owner a signed copy of this Contractor Acknowledgement Statement from each such Subcontractor.

(Legal Name of Company)

(Address)

(Type Name of Officer)

(Signature of Officer)

(Title)

(Date)

REVISION LOG

The following is provided for convenience to the Owner, Architect/Engineer and Contractor to track changes between annual document issuances and is not to be considered by any party to be contractual or 100% complete.

Date	Paragraph Revised
02/01/08	Correct numbering in Section 3.8
06/01/08	Include SafetyNet Program in Section 2.4
04/01/09	Reissue date of substantially revised document. (not posted to eManual)
04/26/10	Reissue date of substantially revised document. Notable changes include: <ul style="list-style-type: none"> • increased experience level and qualifications of the Project Safety Coordinator (PSC) and Project Safety Assistant(s) (PSA) • modified the number of PSAs required on a Project and their start and conclusion of service days • increased credit for formal education, continuing education, and certification for PSCs and PSAs • modified OSHA 10/30 hour training requirements • modified hard hat sticker process for equipment operators • modified safety vest requirement • modified height requirement for ladder use without fall protection • removed other exemptions for fall protection • added visitor waiver and release requirement and document • other cosmetic changes with no impact to content or intent of specifications.
3/24/11	Inclusion of criminal background check requirement and associated forms
5/17/11	Removal of criminal background check requirement and associated forms
9/1/12	Clarifications to align with SafetyNet data gathering and Exhibit title revisions
12/18/15	Inclusion of PSC in training and other minor clarifications
9/21/18	<ul style="list-style-type: none"> • Reformatted text describing requirements that exceed OSHA requirements; added statement at the beginning calling attention to the reformatted text; misc. edits • In general, clarified Owner's expectations and existing requirements throughout this document with revised terminology to align with industry • Updated reference to Safety Data Sheets in 2.11.2 and in Exhibits D and E • Added sections 2.12.18 through 2.12.21 • Clarified section 3.1.1 to ensure this specification is received and reviewed by subcontractors • Deleted section 3.1.7 in its entirety • Clarified section 3.2.2 regarding expectation of PSC/PSA admin duties • Clarified section 3.2.4 regarding Owner's position on Safety Recognition and Commendation

	<ul style="list-style-type: none">• Added section 3.5.6 requiring the PSC to communicate the expulsion of a worker from the project site• Added section 3.6.6.4 related to metal fuel containers• Added section 3.6.6.5 related to liquid storage containers larger than 25 gallons• Added section 3.6.7.10 related to housekeeping of means of egress• Clarified requirement in section 3.6.8.5 related to physical barricades at ladder step-off landing areas• Added sections 3.6.10.5 through 3.6.10.7 related to motorized equipment operation• Updated wording to industry standard in Exhibit L• Added Exhibit N – UTS Safety Specification (01 35 23) Contractor Acknowledgment Statement
4/1/2019	<ul style="list-style-type: none">• Added sections 2.1.2 and 2.1.3 related to Project Safety Coordinator qualifications• Updated Exhibit C

SECTION 01 45 00 - PROJECT QUALITY CONTROL**PART 1 - GENERAL****1.1. RELATED DOCUMENTS**

- 1.1.1. Drawings and general provisions of the Contract, including Uniform General and Supplementary General Conditions for University of Texas System Building Construction Contracts (UGC) and other Division 1 – Division 33 Specification Sections, apply to this Section. In the event of conflict between specific requirements of the various documents, the more restrictive, more extensive (i.e., more expensive) requirement shall govern.

1.2. DEFINITIONS**1.2.1. QUALITY CONTROL**

- 1.2.1.1. Quality Control shall be the sole responsibility of the Contractor, unless specifically noted otherwise. The Contractor shall be responsible for all testing, coordination, start-up, operational checkout and commissioning of all items of work included in the project, unless specifically noted otherwise. All costs for these services shall be included in the Contractor's cost of work and general conditions.
- 1.2.1.2. The Contractor shall assign one employee, not the project superintendent, to be responsible for Quality Control. This individual can have other responsibilities, but shall not be the project superintendent or the project manager.

1.2.2. QUALITY ASSURANCE

- 1.2.2.1. Quality Assurance is performed by the Owner or their delegated representatives. These procedures may include observations, inspections, testing, verification, monitoring and any other procedures deemed necessary to ensure compliance with the contract documents.
- 1.2.2.2. The Contractor shall cooperate with and provide assistance to the Owner for all aspects of this endeavor. This shall include providing ladders, lifts, scaffolds, lighting, protection, safety equipment and any other devices and/or equipment (including operators if required) deemed necessary by the Owner to access the work for observation/inspection.

1.3. SUMMARY

- 1.3.1. This section provides administrative and procedural requirements for Contractor quality control on the project.
- 1.3.2. Specific quality-control requirements for individual construction activities are specified in the Sections that govern those activities. Requirements in those Sections may also cover production of manufactured products.

- 1.3.3. Specified tests, inspections, and related actions do not limit Contractor's quality control obligations to comply fully with the Contract Document requirements in all regards.
- 1.3.4. Provisions of this Section do not limit the requirements for the Contractor to provide quality control services required by the contract documents or the Authority Having Jurisdiction.
- 1.3.5. The following quality issues are addressed in detail in this Section:
 - 1.3.5.1. Quality Control
 - 1.3.5.2. Quality Assurance
 - 1.3.5.3. Testing Agency
 - 1.3.5.4. Testing
 - 1.3.5.5. Inspections
 - 1.3.5.6. Pre-installation Meetings
 - 1.3.5.7. Mock-ups
- 1.4. TESTING AGENCY
 - 1.4.1. Testing Agency Qualifications: An agency with the experience and capability to conduct testing and inspecting indicated, as documented by ASTM E 548, and that specializes in types of tests and inspections to be performed.
 - 1.4.2. Owner will employ services of independent testing agencies to perform certain specified testing, as it deems necessary.
 - 1.4.3. The Contractor shall employ and pay for services of an independent testing agency to perform all specified testing requiring an independent agency, unless noted otherwise.
 - 1.4.4. Employment of agency in no way relieves the Contractor of the obligation to perform Work in accordance with requirements of Contract Documents.
 - 1.4.5. The Contractor Employed Agency:
 - 1.4.5.1. Testing agency shall comply with requirements of ASTM E 329, ASTM E 548, ASTM E 543, ASTM C 1021, ASTM C 1077, and ASTM C 1093.
 - 1.4.5.2. Laboratory shall maintain a full time Engineer on staff to review services. Engineer shall be licensed in the state of Texas.
 - 1.4.5.3. Testing Equipment: Calibrate devices at reasonable intervals (minimum yearly) with accuracy traceable to either National Bureau of Standards or accepted values of natural physical constants.

- 1.4.6. The Contractor shall not employ the same testing entity engaged by the Owner for the project, unless agreed to in writing by the Owner.

1.5. TESTING

- 1.5.1. Where specific testing is specified in a technical section of the Specifications or indicated in the Contract Documents, the Contractor shall bear all costs of such tests unless they are specifically stated to be paid by the Owner.
- 1.5.2. Testing specifically identified to be conducted by Owner will be performed by an independent entity and will be arranged and paid for by the Owner unless otherwise indicated in the Contract Documents. Should the test return unacceptable results, the Contractor shall bear all costs of retesting and reinspection as well as the cost of all material consumed by testing, and replacement of unsatisfactory material and/or workmanship.
- 1.5.3. The Owner's Construction Inspector (CI) will schedule the Owner's testing services unless otherwise directed in writing by the Owner. The Contractor is required to coordinate with the CI to facilitate timeliness of such testing services.
- 1.5.4. The Owner may engage additional consultants for testing, air balancing, or other special services. The activities of any such Owner consultants are in addition to Contractor testing of materials or systems necessary to prove that performance is in compliance with requirements. The Contractor must cooperate with persons and firms engaged in these activities in accordance with the Contract.
 - 1.5.4.1. The Contractor is required to self-perform various tests to verify performance and/or operation of various systems. These test reports shall be consecutively numbered and defined by scope and extent of test. Copies of the test report forms can be obtained from the RCM. The following UTHSCH test report forms shall be used for this purpose and shall not be altered in any manner:
 - 1.5.4.1.1. Pipe Test Report
 - 1.5.4.1.2. Duct Test Report
 - 1.5.4.1.3. Equipment Start-up Request Form
 - 1.5.4.1.4. Contractor's Request for Utility Shutdown
 - 1.5.4.1.5. Domestic Water Sterilization and Flushing Report

1.6. INSPECTIONS

- 1.6.1. It is the intent of the Contract Documents that all work be subjected to inspection and verification of correct operation prior to 100% payment of the line item(s) pertaining to that aspect of the Work.
- 1.6.2. The Contractor shall incorporate adequate time for performance of all inspections and correction of noted deficiencies into the Work Progress Schedule for the project.

- 1.6.3. During the course of construction, the Owner, Architect and/or other Owner representatives may visit the site for observation of the work in place. The Contractor shall provide all necessary equipment for safe access to the work to be inspected or observed. This requirement shall extend to all Owner personnel and their representatives. Some of these inspections will be informal and some will require formal notification by the Contractor. The following are typical project inspections:
- 1.6.3.1. Informal Daily Reviews of project conditions by the Construction Inspector and/or members of the Owner's and/or Design Consultant's team(s). When considered appropriate, results of these reviews will be documented via Observation Report or Memorandum. In addition to cooperating with, and providing safe access for the Owner's agents, the Contractor shall provide a system of tracking all field reports, describing items noted and resolution of each item. This printed report shall be reviewed as necessary, at least on a monthly basis.
 - 1.6.3.2. Concealed Space Inspections are to be formally scheduled in advance through the Construction Inspector by submitting written notification at least five (5) workdays in advance. Subject areas include partitions, structural walls, chases, crawl spaces, ceiling spaces, and any other work which will be difficult or impossible to examine once concealed in the final construction.
 - 1.6.3.3. Progress Inspections for piping, ductwork, and other systems are to be scheduled with the Construction Inspector as appropriate portions, or sections, of the work are completed. This is in addition to "system-wide" performance verification and tests. These tests are to be scheduled and documented using the standard UTHSCH Pipe Test and Duct Test report forms. The forms shall be filled out and signed as meeting contract requirements prior to submission for verification by the UTHSCH CI. The Contractor shall conduct the tests and the UTHSCH CI will witness and approve the results.
 - 1.6.3.3.1. The Contractor shall coordinate their intended "apportioning" of systems tests with the Construction Inspector immediately following formal submission of their Work Project Schedule so that all parties are aware of the intended work and inspection sequence.
 - 1.6.3.4. Overhead and Above Ceiling Inspections are similar in nature and requirements to the Concealed Space Inspections. Where ceilings are to be fixed in place, such as gypsum board or plaster, it would constitute a Concealed Space. Where ceilings are of "lay-in" type, or where no finish ceiling is scheduled, it would be considered an "overhead" inspection. Such inspections are to be included in the Contractor's Detailed Construction Schedule. Contractor shall provide written inspection request notice to the CI and Architect at least five (5) workdays in advance.
 - 1.6.3.4.1. No finish ceiling material shall be installed until all overhead punchlist items have been resolved to the satisfaction of the Owner.
 - 1.6.3.4.2. Work in place necessary for an overhead inspection shall include:

- 1.6.3.4.2.1. Ceiling grid or framework installed
 - 1.6.3.4.2.2. All above ceiling electrical work, including light fixtures, installed and operational
 - 1.6.3.4.2.3. All HVAC and plumbing work above ceiling complete with diffusers installed and connected
 - 1.6.3.4.2.4. Fire sprinkler heads installed
 - 1.6.3.4.2.5. All required tests for above ceiling work completed and approved
 - 1.6.3.4.2.6. Contractor generated punchlist of all areas being requested for inspection
- 1.6.3.5. Inspections of Building Systems and Equipment are required to confirm acceptable operation and are to be formally scheduled through the Construction Inspector with the Architect. Refer to Section 01 91 00 for additional requirements pertaining to system start-up, operation, demonstration and acceptance.
- 1.6.4. On systems/equipment requiring a manufacturer's representative to verify installation/operation, the Contractor is required to perform a thorough check-out of operations with the manufacturer's representatives prior to requesting formal inspection by the Owner be scheduled. Notify the CI, in advance, as to when the manufacturer's representative is scheduled to arrive.
- 1.6.5. Inspection of individual equipment and/or system(s) must be accomplished prior to requesting Substantial Completion Inspection for any area affected by that equipment and/or system.
- 1.6.6. For "building-wide" and/or life safety systems, such as fire alarm, fire sprinkler systems, smoke evacuation systems, toxic gas monitoring, captured exhaust systems, etc., completion and acceptance of Functional Testing is required prior to requesting Substantial Completion Inspection for any area of the Project.
- 1.6.6.1. The manufacturer's representatives and the installing contractor will be expected to demonstrate both operation and compliance to the Owner's agents and consultants. If coordinated and scheduled appropriately by the Contractor, these equipment and/or systems inspections may also serve to provide the required Owner Training, if approved in advance by the Owner.
 - 1.6.6.2. The Contractor is responsible for requesting that the Construction Inspector and Architect arrange for the inspection of materials, equipment and work prior to assembly or enclosure that would make the materials, equipment or work inaccessible for inspection, and at such other times as may be required.
- 1.6.7. For any requested inspection, the Contractor shall make prior inspection to ensure that items are ready for inspection and acceptance by the Owner and/or Architect.

The Contractor will be responsible for any and all costs incurred by Owner and/or Owner representatives, including consultants, resulting from a review or inspection that was scheduled prematurely.

1.6.8. The Contractor shall coordinate the work and schedule the inspections in advance so as not to delay the work. All major inspections should be indicated on the Work Progress Schedule for advance planning and the Contractor should allow a minimum of five (5) working days to confirm schedule of requested inspections with Owner and its consultants.

1.6.9. The contractor shall list and track all punchlist items on the UTHSCH Project Inspection Matrix (refer to Attachment A). The matrix shall be kept up-to-date reflecting status of work in place and inspections on the project. Copies of this populated and updated matrix shall be supplied to the A/E and the UTHSCH CI for use during the course of the project.

1.7. PRE-INSTALLATION MEETINGS

1.7.1. The Contractor shall coordinate and conduct meetings to review the installation of major systems/equipment on the project.

1.7.2. The Contractor shall ensure attendance of the installing subcontractor, manufacturer and/or supplier (if appropriate), supporting subcontractors involved in the installation and any other parties involved in the phase of work to be reviewed. The Owner and Architect shall be notified in writing at least five (5) days in advance of the meeting.

1.7.3. Each party shall be prepared to discuss in detail the staging, installation procedure, quality control, testing/inspection, safety and any other pertinent items relating to the work being reviewed. Submittal approval shall be a prerequisite of the meeting.

1.7.4. The Contractor shall chair and take minutes of this meeting and distribute to all attending parties.

1.7.5. Whether required in the technical section or not, a pre-installation meeting shall be conducted for the following work, if included in the project:

1.7.5.1. Concrete

1.7.5.2. Masonry

1.7.5.3. Large Steel Fabrications/Erection

1.7.5.4. Waterproofing

1.7.5.5. Roofing

1.7.5.6. Exterior Glazing (including storefront and curtain wall)

1.7.5.7. Door Hardware

- 1.7.5.8. Security
- 1.7.5.9. Audio/Visual Equipment
- 1.7.5.10. Air Handling Units
- 1.7.5.11. Medical Gas Systems
- 1.8. MOCK-UPS
 - 1.8.1. Before installing portions of the Work requiring mockups, build mockups for each form of construction and finish required, using materials indicated for the completed Work.
 - 1.8.2. Build mockups in location and of size indicated or, if not indicated, as directed by Architect. The mock-up may be work in place that is intended to remain, unless otherwise directed by the Owner.
 - 1.8.3. Notify Architect and Owner five (5) working days in advance of dates and times when mockups will be constructed.
 - 1.8.4. Demonstrate the proposed range of aesthetic effects and workmanship. Include anticipated repairs in mockup, such as stone veneer.
 - 1.8.5. Obtain Architect's and Owner's approval of mockups before starting work, fabrication, or construction.
 - 1.8.6. Maintain mockups during construction in an undisturbed condition as a standard for judging the completed Work.
 - 1.8.7. Demolish and remove mockups when directed, unless otherwise indicated.
 - 1.8.8. For any of the following work items included in the project, a mockup shall be prepared whether required by the technical section or not:
 - 1.8.8.1. Exterior wall system to include: substructure, masonry/stone veneer, plaster, architectural concrete and windows.
 - 1.8.8.2. Roof system
 - 1.8.8.3. Interior lab room
 - 1.8.8.4. Interior patient care room
 - 1.8.8.5. Interior wall finishes
 - 1.8.8.6. Ceramic tile
 - 1.8.8.7. Finished flooring

PART 2 - PRODUCTS (NOT USED)

PART 3 - EXECUTION (NOT USED)

END OF SECTION 01 45 00

ATTACHMENT A – UTHSCH PROJECT INSPECTION MATRIX

OFFPC PROJECT INSPECTION MATRIX

Office of Facilities Planning & Construction

Project Number:

Project Name:

OFFPC Construction Inspector:

Contractor Inspector:

PROJECT AREA & SYSTEM INSPECTION LIST									
Item #	Inspection Type	Location	Date Initiated	Date of Follow Up Inspection	Date of Final Sign-Off	OFFPC Final Sign-Off			Comments
1	Above Ceiling	Corridors East of Interaction 6/3005	06/28/05	07/13/05	07/28/05	Jane Smith			
2	Hydronic Hot Water	Mech. Space	06/28/05	07/13/05	07/28/05	Jane Smith			
3	Pre-Final all AHU	Mech. Space	06/29/05	07/14/05	07/29/05	Jane Smith			
4	Chilled water	Mech. Space	06/30/05	07/15/05	07/30/05	Jane Smith			
5	Exhaust Fans	Mech. Roof	07/07/05	07/22/05	08/06/05	Jane Smith			
6	Pre-Final Electric System	Various	07/09/05	07/24/05	08/08/05	Jane Smith			
7	R.O. Water System	Mech. Room	07/12/05	07/27/05	08/11/05	Jane Smith			
8	Roof	Roof/system	07/21/05	08/05/05	08/20/05	Jane Smith			
9	Exterior Bldg	All	07/25/05	08/09/05	08/24/05	Jane Smith			
10	Hardscape	All	07/29/05	08/13/05	08/28/05	Jane Smith			
11	Substantial Completion	All	08/04/05	08/19/05	09/03/05	Jane Smith			
12	Point to Point	All	08/16/05	08/31/05	09/15/05	Jane Smith			
INDIVIDUAL INSPECTION ITEM LIST									
Item #	Level	Room	Item Description	Date Inspected	Responsible Sub	Contractor Sign-Off	OFFPC Final Sign-Off		Comments
1	1	1.304B.5	Cut drops on fire sprinkler.	05/11/05	Simplex	John Doe	Jane Smith		
2	1	1.304B.5	Adjust hangers on fire sprinkler pipe to meet spec.	05/11/05	Simplex	John Doe	Jane Smith		
3	1	1.304B.4	Support wires for ceiling need to be moved where touching other work.	05/11/05	MBS	John Doe	Jane Smith		
5	1	1.304B.4	Complete installation of conduit and boxes for electrical.	05/11/05	Design	John Doe	Jane Smith		
6	1	1.304B.4	Complete installation of conduit and boxes for controls.	05/11/05	Siemens	John Doe	Jane Smith		
7	1	1.304B.4	Cut drops on fire sprinkler.	05/11/05	Simplex	John Doe	Jane Smith		
8	1	1.304B.4	Adjust hangers on fire sprinkler pipe to meet spec.	05/11/05	Simplex	John Doe	Jane Smith		
9	1	1.304B.4	Support cables for remote damper adjustment.	05/11/05	Todd-Ford	John Doe	Jane Smith		
10	1	1.304B.5	Plug ball valve above ceiling.	05/11/05	Simplex	John Doe	Jane Smith		
11	1	1.304B	Support wires for ceiling need to be moved where touching other work.	05/11/05	MBS	John Doe	Jane Smith		
12	1	1.304B	Seal all holes in masonry floor.	05/11/05	Todd-Ford	John Doe	Jane Smith		
13	1	1.304B	Complete installation of conduit and boxes for electrical.	05/11/05	Design	John Doe	Jane Smith		
14	1	1.304B	Complete installation of conduit and boxes for controls.	05/11/05	Siemens	John Doe	Jane Smith		
15	1	1.304B	Cut off all-thread on hangers to one inch.	05/11/05	Various	John Doe	Jane Smith		
16	1	1.304B	Cut drops on fire sprinkler.	05/11/05	Simplex	John Doe	Jane Smith		
17	1	1.304B	Adjust all-thread on hangers to prevent touching other work or isolate	05/11/05	Various	John Doe	Jane Smith		
18	1	1.304B.2	Remove unused all-thread above East wall	05/11/05	Todd-Ford	John Doe	Jane Smith		
19	1	1.304B.2	Remove or re-attach metal stud corner brace	05/11/05	MBS	John Doe	Jane Smith		
20	1	1.304B.2	Cut drops on fire sprinkler.	05/11/05	Simplex	John Doe	Jane Smith		
21	1	1.304B.1	Cut drops on fire sprinkler.	05/11/05	Simplex	John Doe	Jane Smith		
22	1	1.304B.1	Adjust all-thread on hangers to prevent touching other work or isolate	05/11/05	Todd-Ford	John Doe	Jane Smith		
23	1	1.304A	Complete shower chase and ceiling framing	05/11/05	MBS	John Doe	Jane Smith		
24	1	1.304A	Complete installation of conduit and boxes for electrical.	05/11/05	Design	John Doe	Jane Smith		
25	1	1.304A	Complete installation of conduit and boxes for controls.	05/11/05	Siemens	John Doe	Jane Smith		
26	1	1.304A	Cut drops on fire sprinkler.	05/11/05	Simplex	John Doe	Jane Smith		
27	1	1.304A	Cut off all-thread on hangers to one inch	05/11/05	Various	John Doe	Jane Smith		
28	1	1.304A	Remove or re-connect loose all thread	05/11/05	Simplex	John Doe	Jane Smith		
29	1	1.304A	Label copper lines	05/11/05	Todd-Ford	John Doe	Jane Smith		
30	1	1.304A	Cut off all-thread on hangers to one inch	05/11/05	Various	John Doe	Jane Smith		



The University of Texas
Health Science Center at Houston

REVISION LOG

The following is provided for convenience to the Owner, Architect/Engineer and Contractor to track changes between annual document issuances and is not to be considered by any party to be contractual or 100% complete.

Date	Paragraph Revised
02/01/08	Added section 1.6.9 - The contractor shall list and track all punchlist items on the UTHSCH Project Inspection Matrix...
02/01/08	Added Attachment A

SECTION 01 57 23 - TEMPORARY STORM WATER POLLUTION CONTROL

PART 1 - GENERAL

1.1 DEFINITIONS

- 1.1.1 BMP – Best Management Practices
- 1.1.2 CSN –Construction Site Notice- (Large CSN for large sites; Small CSN for small sites)
- 1.1.3 NOI and NOT – Notice of Intent and Notice of Termination for TPDES permits
- 1.1.4 SWPPP – Storm Water Pollution Prevention Plan
- 1.1.5 TCEQ – Texas Commission on Environmental Quality
- 1.1.6 TPDES – Texas Pollutant Discharge Elimination System
- 1.1.7 Large Construction Activities – Construction activities including clearing, grading and excavating that result in land disturbance equal to or greater than 5 acres of land
- 1.1.8 Small Construction Activities - Construction activities including clearing, grading and excavating that result in land disturbance equal to or greater than 1 acre and less than 5 acres of land

1.2 RELATED DOCUMENTS AND APPLICABLE WORK

- 1.2.1 The TCEQ TPDES General Permit No. TXR150000 effective March 5, 2013 and the project SWPPP. This specification requires compliance with all provisions of the TCEQ TPDES permit. The TCEQ requirements currently pertain to large construction activities of 5 acres or more and small construction activities that disturb 1 to less than 5 acres.
- 1.2.2 Information to Respondents, Agreement, Uniform General and Supplementary General Conditions for The University of Texas System Building Construction Contracts (UGC) and Special Conditions shall be read carefully for provisions pertaining to this work. In the event of conflict, the better quality or greater quantity shall prevail.
- 1.2.3 The work described in this section is applicable to any and all sections of the contract documents. Any and all work that would disturb the existing site conditions or present the potential for site runoff shall adhere fully to this specification section.
- 1.2.4 Unless specifically notified to the contrary in writing by the Owner, all aspects of this specification shall apply to this project.

1.3 CONTRACTOR RESPONSIBILITIES

- 1.3.1 This project requires implementation of storm water Best Management Practices for control devices and monitoring by the Contractor to comply with all provisions of the SWPPP developed for the project by the licensed civil engineer. The Contractor must fulfill all TPDES regulatory requirements, including the filing of the NOI and NOT or signing and posting of the CSN.
- 1.3.2 The Contractor shall provide signatures of a Corporate Officer for the NOI, Large CSN, Small CSN, NOT and any other forms or applications as required by the TPDES General Permit TXR150000. The Contractor shall also provide delegated authorization to sign reports per 30 TAC 305.128. Individuals conducting site inspections shall be qualified to the satisfaction of the Owner.
- 1.3.3 When the Contractor receives the approved SWPPP from the Owner, the Contractor signs the NOI or Small CSN (see Sample form in Part 4 of this section) and forwards it to the Owner. Two separate \$325 application fees (one for the Owner and one for the Contractor) must accompany the NOI. The Owner signs his NOI and sends both NOIs and application fees to TCEQ. The Contractor shall insert a copy of the signed NOI or Small CSN into the SWPPP book to be kept at the jobsite. The \$325 application fees are not required for small construction sites.
- 1.3.4 The SWPPP book kept at the jobsite shall also contain the following:
- 1.3.4.1 A letter delegating signature authority to the field personnel for both the Contractor and the Owner
 - 1.3.4.2 A copy of the TPDES permit when received
 - 1.3.4.3 A copy of the Large or Small CSN
 - 1.3.4.4 A copy of the Shared SWPPP Acceptance Certification form
- 1.3.5 The Contractor shall review the SWPPP and verify existing conditions at the site before determining scope of implementation of site controls. Site survey and site plan drawings shall be used for additional reference. The Contractor shall notify the Owner, in advance, of this site review to allow for Owner participation.
- 1.3.6 The Contractor shall construct a Project SWPPP sign and place it at the main entrance to the project site. This sign shall include the NOI and TPDES permit along with the TCEQ TPDES Large or Small CSN, depending on the size of the construction project. The sign shall be constructed as detailed in the sample SWPPP sign drawing included in Part 4 of this Section.
- 1.3.7 The Contractor shall contact the UTHSCH Construction Inspector (CI) for review of initial site controls in place prior to commencing site-disturbing activities, to ensure that any unusual circumstances or unforeseen site conditions

with regard to erosion

and sedimentation have been addressed. The Contractor shall complete the SWPPP Project Start-up form (see Sample in Part 4 of this Section)) and review it with the Owner before commencing soil disturbing activities. Both parties shall sign this form when the requirements listed in the SWPPP Project Start-up form have been met.

- 1.3.8 The Contractor shall provide all material, labor, equipment and services required to implement, maintain and monitor all erosion and sedimentation controls in compliance with the SWPPP. All controls implemented by the Contractor shall comply with the TPDES regulations as issued by the TCEQ on March 5, 2013. These controls shall remain in operation until project completion and re-establishment of the site or longer as directed by the UTHSCH Resident Construction Manager (RCM). The work shall include, but not be limited to, the following:
 - 1.3.8.1 All earthwork as required to implement swales, dikes, basins and other excavations for temporary routing of utilities, to protect against erosion or sediment-laden (polluted) storm water runoff.
 - 1.3.8.2 All structural controls as shown or specified, including silt fences, sediment traps, stabilized construction entrance, subsurface drains, pipe slope drains, inlet/outlet protection, reinforced soil retention, gabions, rock berms, etc.
 - 1.3.8.3 All non-structural controls as shown or specified, including temporary or permanent vegetation, mulching, geotextiles, sod stabilization, preservation of vegetative buffer strips, preservation/protection of existing trees and other mature vegetation.
 - 1.3.8.4 All modifications and revisions to SWPPP necessary to meet changing site conditions and to address new sources of storm water discharges, as the work progresses.
 - 1.3.8.5 All maintenance and repair of structural and non-structural controls in place shall continue until final stabilization is achieved or as directed by the RCM.
 - 1.3.8.6 Weekly site inspections, as required by the SWPPP, of pollutant sources, including hazardous sources, structural and non-structural controls, and all monitoring of SWPPP revisions and maintenance of inspection records.
 - 1.3.8.7 Removal of all structural and non-structural controls as necessary upon completion, and only after final stabilization is achieved.
 - 1.3.8.8 Filing of NOT with the RCM within 30 days of final stabilization being achieved and being approved by the Owner, or of another Operator assuming control of the unstabilized portions of the site.
 - 1.3.8.9 Refer to the SWPPP for additional requirements to ensure compliance with TPDES regulations.

1.4 QUALITY ASSURANCE

- 1.4.1 In order to minimize the discharge of pollutants to storm water, the Contractor shall implement all permanent and temporary site controls according to TPDES Guidelines, as set forth by the TCEQ.
- 1.4.2 Implementation of site controls shall be performed by a qualified contractor experienced in the proper installation of such devices in accordance with manufacturers' specifications, and in keeping with recognized Best Management Practices (BMPs), and in keeping with TPDES regulations. Qualification of installing Contractor shall be reviewed with the Owner prior to entering into a contract with them for services.
- 1.4.3 The Contractor shall inspect all BMPs at regular intervals as specified in the Storm Water Pollution Prevention Plan for this project. Use standard Owner Inspection forms (see form at the end of this Section) for each inspection. Record all deficiencies of site controls, and take immediate action to correct any deficiencies recorded. Keep records of inspections current and on file, available for review by EPA, TCEQ, MS4 Operator and Owner.

1.5 SUBMITTALS

- 1.5.1 Submittals of products used in structural and non-structural controls shall be made through established procedures for review and approved by the Owner prior to installation on the site. The Contractor shall make available physical samples and product literature on any material used in structural or non-structural controls during the course of the project prior to its implementation in the field.

PART 2 - PRODUCTS

2.1 MATERIALS

Specific site control devices are identified in the SWPPP. Where such devices are indicated, their material composition shall comply with this section.

- 2.1.1 Materials to be used in structural and non-structural site controls shall include, but not be limited to the following:
 - 2.1.1.1 **Area Inlets, Curb Inlets and Silt Fences:** implemented to filter and remove sediment from storm water; they shall be composed of the following materials:
 - a. Geotextile fabric – a non-woven, polypropylene, polyethylene, or polyamide fabric with non-raveling edges. It shall be non-biodegradable, inert to most soil chemicals, ultraviolet resistant, unaffected by moisture and other weather conditions, and permeable to water while retaining sediment. Fabric shall be 36 inches wide, with a minimum weight of 4.5 oz./yd.

- b. Wire Backing – a galvanized, 2"x4" welded wire fencing, 12-gauge minimum. Width shall be sufficient to support geotextile fabric 24 inches above adjacent grades. Chain link fences located along the same lines as silt fences may be used to support geotextile fabric. In this circumstance, the geotextile fabric shall be firmly attached to the fence.
 - c. Posts for area inlets and silt fences – steel fence posts shall be made of hot rolled steel, galvanized or painted, a minimum of 4 feet long, with a Y-bar or TEE cross-section of sufficient strength to withstand forces implied.
- 2.1.1.2 **Rock Berms:** shall be composed of the following materials:
- a. Rock – clean open graded rock, with a maximum diameter of 3 inches
 - b. Wire Mesh Support – a galvanized, woven wire sheathing having a maximum opening size of 1 inch, and a minimum wire diameter of 20 gauge
 - c. Ties – metal hog rings or standard wire/cable ties
- 2.1.1.3 **Triangular filter dikes:** for use on surfaces or in locations where standard silt fence cannot be implemented, shall be composed of the following:
- a. Geotextile fabric – a non-woven, polypropylene, polyethylene, or polyamide fabric with non-raveling edges, with a minimum width of 60 inches
 - b. Dike Structure – 6-gauge, 6" x 6" welded wire mesh, 60 inches wide, folded into a triangular form. Each side shall be 18 inches with an overlap of 6 inches
 - c. Ties – metal hog rings or standard wire/cable ties for attachment of wire mesh to itself, and for attachment of geotextile fabric to wire mesh
- 2.1.1.4 **Stabilized construction exit:** a steel grid that allows the safe passage of vehicles while agitating the tires to loosen and remove the soil buildup. The grid or structures shall conform to the following:
- a. It shall consist of pipes or tubes spaced such that there is a minimum clear distance between the pipes or tubes of 4½ inches. It shall be elevated above the ground surface a minimum of 8 inches to allow water, debris and soil to drain.
 - b. Minimum diameter of pipe or tube shall be 3 inches.
 - c. It shall be designed to support any and all vehicles entering and leaving the construction site.
 - d. It shall be firmly placed in the ground at the exit.
 - e. It shall be of sufficient length so that the agitation will remove the soil from the tires, or a minimum of 12 feet.
 - f. At the street side approach of the grid there shall be an impervious surface or it shall consist of 3" to 5" diameter angular crushed stone/rock approximately 5 feet in length, minimum, and 8 inches deep, minimum. On the job site side of the grid, there shall be 3" to 5" diameter angular crushed stone/rock 15 feet in length, a minimum of 8

- inches deep. The steel grid will be between the street side approach and the job site crushed stone/rock. All crushed stone/rock shall have filter fabric beneath the stone/rock. See diagram on Exhibit F.
- g. Steel grid area shall be used as the tire wash area. When tire wash is in use (rainy or muddy days), the area shall be manned and the tires shall be washed using a high pressure hose/nozzle.
 - h. The area beneath the grid shall be sloped such that debris, soil and water shall be diverted back onto the construction site or to a sediment basin. No water, soil or debris shall leave the construction site. The resulting discharge shall be disposed of properly.
- 2.1.1.5 **Concrete Truck Washout:** shall be used for containment of fluids from concrete truck washout wastes.
- a. Gravel bags, concrete blocks or open graded rock
 - b. 10 mil plastic sheeting
- 2.1.1.6 **Temporary Storage Tanks:** shall be used for temporary storage of fuels on the construction project site
- a. 2 inches of sand on the bottom of the containment area
 - b. 6 mil plastic sheeting
 - c. 2 inches of sand on top of the plastic sheeting
- 2.1.1.7 **Erosion Control Matting:** shall be used on steep slopes, in drainage swales, and in high traffic pedestrian areas of barren soil. It shall include one or more of the following:
- a. Jute Mat – a plain fabric made of jute yarn, woven in a loose and simple manner, with a minimum unit weight of 2.7 pounds per square yard. Width shall be as required for the dimensions of the area to be covered.
 - b. Wood Fiber Mat – a mat composed of wood fibers, which are encased in nylon, cotton or other type of netting
 - c. Synthetic Webbing Mat – a mat manufactured from polyvinyl chloride or polypropylene monofilaments, which are bonded together into a three-dimensional web to facilitate erosion control and/or re-vegetation.
- 2.1.1.8 **Organic mulches:** shall be used for covering bare soil, retaining moisture under existing vegetation being preserved, and for absorbing the energy of compaction caused by foot or vehicular traffic. Mulch shall be one or more of the following:
- a. Straw – from broken straw bales that are free of weed and grass seed where the grass from the seed is not desired vegetation for the area to be protected.
 - b. Wood Chips – from chipped limbs of cleared trees on site, or delivered in chipped form, in bulk quantities of pine, cedar or cypress. Wood chips of all species shall be partially decomposed to alleviate nitrogen

depletion of the soil in areas where existing vegetation is to be preserved and protected.

- c. Shredded Mulches – from pine, cypress or cedar, mechanically shredded, and capable of forming an interlocking mat following placement, and after sufficient wetting and drying has taken place naturally.

2.1.1.9 Any other materials indicated in the SWPPP.

PART 3 - EXECUTION

3.1 GENERAL

- 3.1.1 The Contractor shall provide a complete installation of all site control devices and measures (BMPs) indicated in the SWPPP book, including the Site Erosion and Sedimentation Control Drawing and as specified herein. These BMPs must be confirmed as fully operational with the Owner before any work that disturbs the site can begin.

As an alternative to the BMPs indicated in the SWPPP book, the Site Erosion and Sediment Control Drawing and as specified herein, the Contractor may propose alternate BMPs that perform the same function as the indicated BMP but may be of a different configuration, material or type for review and approval by UTHSCH. Installation of alternate BMPs shall not proceed until approved by UTHSCH.

- 3.1.2 The Contractor shall provide inspection and monitoring of controls in place and shall perform all revisions and updating of SWPPP book. An accurate, chronological record of all Contractor inspections, revisions and additional controls shall be kept on file at the project site, for review, with a copy of the SWPPP book.
- 3.1.3 The Contractor shall submit their NOT to the Owner after all disturbed areas are re-established (stabilized) with vegetative cover following completion of construction. Following acceptance of stabilized areas, all site controls that are no longer necessary shall be removed.

3.2 CONTROL DEVICES

Execution of specific site control devices is described in the following paragraphs. Refer to the SWPPP for applicable devices, extent and location.

3.2.1 AREA INLET DETAIL

- 3.2.1.1 Area inlet fences shall consist of non-woven geotextile fabric attached to wire fabric backing to support the geotextile. The wire fabric should be galvanized 2" x 4" welded wire, 12-gauge minimum. Attach non-woven geotextile fabric to the fence with hog rings or standard cable/wire ties, leaving a toe of fabric at the bottom of the fence of not less than 6 inches. Steel posts as specified shall be driven to a depth of 1 foot minimum and spaced not more than 6 feet

on center. Attach fencing to posts with standard cable/wire ties. Abutting ends of geotextile fabric shall be overlapped a minimum of 12 inches. Wrap grates with non-woven geotextile fabric. See Exhibit A at end of section.

- 3.2.1.2 Maintain silt fence daily as necessary to repair breaches in geotextile fabric. Maintain steel posts as specified in tilted condition. When siltation has occurred, it shall be removed when it has reached a depth of 6 inches. Silt that has been removed shall be disposed of offsite.
- 3.2.1.2 Remove area inlet when the disturbed areas have been completely stabilized as specified. Minimize site disturbance while removing area inlet protection and posts.

3.2.2 CURB INLET PROTECTION

- 3.2.2.1 Cover curb storm inlet with non-woven geotextile fabric covered wire fabric. Wire fabric to be 2"x4" – W1.4 x W1.4. Extend fabric 2 feet beyond inlet opening at each end and 12 inches in front of opening in the gutter. Remove a strip of filter fabric approximately 12 inches high for the length of the protection to act as overflow. Extend fabric over the top of opening to allow placement of gravel bags. Anchor fabric with 20 lb. gravel bags placed 3 feet on center. See Exhibit B at end of section.
- 3.2.2.2 Maintain inlet protection daily as necessary to repair breaches in geotextile fabric. When siltation has occurred, it shall be removed when it has reached a depth of 2 inches. Silt that has been removed shall be disposed of offsite.

3.2.3 ROCK BERM

- 3.2.3.1 Rock berm shall consist of rip-rap type rock, secured within a wire sheathing as specified, and installed at the toe of slopes, or at the perimeter of developing or disturbed areas. Height of berm shall be a minimum of 18 inches from top of berm to uphill toe of berm. Top width shall be a minimum of 24 inches, with side slopes of 2:1 or flatter. Uphill toe of berm shall be buried a minimum of 4 inches into existing grade. Rock berm shall have a minimum flow-through rate of 60 gallons per minute per square foot of berm face. See Exhibit C at end of section.
- 3.2.3.2 Maintain rock berm in a condition that allows the sediment to be removed, when the depth of sediment has reached 1/3 the height of the berm. Berm shall be reshaped as needed, and silt buildup removed, to maintain specified flow through berm.
- 3.2.3.3 Rock berm shall be removed when the disturbed areas served have been stabilized as specified.

3.2.4 SILT FENCE

- 3.2.4.1 Silt fences shall consist of non-woven geotextile fabric, attached to wire fabric backing to support the geotextile. The wire fabric should be galvanized 2" x 4" welded wire, 12-gauge minimum. Attach non-woven geotextile fabric to fence with hog rings or standard cable/wire ties, leaving a toe of fabric at the bottom of the fence of not less than 6 inches. Steel posts as specified shall be driven to a depth of 1 foot minimum and spaced not more than 6 feet on center. Tilt posts slightly, in an uphill direction for additional strength. Attach fencing to posts with standard cable/wire ties. Dig a 6 inch deep by 6 inch wide trench on the disturbed side of the fence, bury geotextile fabric in trench, backfill and tamp. Abutting ends of geotextile fabric shall be overlapped a minimum of 12 inches. See Exhibit D at end of section.
- 3.2.4.2 Maintain silt fence daily as necessary to repair breaches in geotextile fabric. Maintain steel posts as specified in tilted condition. When siltation has occurred, it shall be removed when it has reached a depth of 6 inches. Silt that has been removed shall be disposed of offsite.
- 3.2.4.3 Remove silt fence when the disturbed areas protected by silt fence have been completely stabilized as specified. Minimize site disturbance while removing silt fence and posts.

3.2.5 TRIANGULAR DIKE

- 3.2.5.1 See Exhibit E for information regarding installation of Triangular Dike

3.2.6 STABILIZED CONSTRUCTION EXIT

- 3.2.6.1 A steel grid that allows the safe passage of vehicles while agitating the tires to loosen and remove the soil buildup. The grid or structures shall conform to the following:
- a. It shall consist of pipes or tubes spaced such that there is a minimum clear distance between the pipes or tubes of 4½ inches. It shall be elevated above the ground surface a minimum of 8 inches to allow water, debris and soil to drain.
 - b. Minimum diameter of pipe or tube shall be 3 inches.
 - c. It shall be designed to support any and all vehicles entering and leaving the construction site.
 - d. It shall be firmly placed in the ground at the exit.
 - e. It shall be of sufficient length so that the agitation will remove the soil from the tires or a minimum of 12 feet.
 - f. At the street side approach of the grid, there shall be an impervious surface or it shall consist of 3" to 5" diameter angular crushed stone/rock approximately 5 feet in length, minimum, and 8 inches deep, minimum. On the job site side of the grid, there shall be 3" to 5" diameter angular crushed stone/rock 15 feet in length, minimum, and 8 inches deep, minimum. The steel grid will be between the street side

approach and the job site crushed stone/rock. All crushed stone/rock shall have filter fabric beneath the stone/rock. See diagram on Exhibit F at end of section.

- g. Steel grid area shall be used as the tire wash area. When tire wash is in use (rainy or muddy days) the area shall be manned and the tires shall be washed using a high pressure hose/nozzle.
- h. The area beneath the grid shall be sloped such that debris, soil and water shall be diverted back on to the construction site or to a sediment basin. No water, soil or debris shall leave the construction site. The resulting discharge shall be disposed of properly.
- i. The stabilized construction exit shall be properly maintained throughout the entire construction process until removal is approved by UTHSCH.

3.2.7 CONCRETE/PAINT/STUCCO/EQUIPMENT WASHOUT (SELF INSTALLED)

- 3.2.7.1 Concrete Truck Washout (self installed) shall be constructed so that it will be able to accommodate the maximum number of anticipated concrete trucks that will be cleaned on any given day at any given time using 7 gallons of water for washout per truck or 50 gallons of water to wash out pump trucks. The area utilized to contain the wash water and concrete solids cleaned from the trucks will be a minimum of 10 feet in width. The containment area will be covered with 10 mil plastic sheeting without any holes or tears and the seams shall be sealed according to manufacturer's recommendations. The gravel bags, concrete blocks or open graded rocks shall line the outside perimeter and shall be double wrapped with the 10 mil plastic sheeting to prevent any potential for runoff from the containment area. See Exhibit G at end of section.
- 3.2.7.2 The concrete truck washout containment area shall be maintained in a condition that will not allow concrete buildup within the containment area to exceed 50% of the storage capacity.
- 3.2.7.3 The concrete truck washout area will be removed when it is no longer necessary to wash out concrete trucks on the site.
- 3.2.7.4 Equipment Cleaning: Clean equipment in a manner that does not create any discharge of cleaning agents, paints, oil or solvents to a storm sewer, waterway or onto the ground. Soaps and detergents must never be discharged to the ground. Cement handling equipment must be rinsed in a contained area and there must be no drainage off-site or onto to ground.
- 3.2.7.5 When rinsing painting equipment/tools outside, rinse water must be contained in a bucket or other container for appropriate disposal. Water based or latex paint rinse water may be discharged to the sanitary sewer only with permission/approval from UT EH&S.
- 3.2.7.6 Oil based paint wastes, including solvents and thinners, must not be disposed

of in the sanitary sewer; they must be collected and disposed of through the contractor's disposal company in accordance with applicable laws and regulations.

- 3.2.7.7 Discharges from pressure washing using soaps or chemicals must not be allowed to enter a storm sewer. The wastewater will need to be collected with a berm and vacuumed (transported to appropriate disposal site). If the rinse only contains water and dirt (sediment) it may be spread on a grass area or contained/filtered with clean water allowed to enter storm sewer. In some cases it may also be possible to discharge to a sanitary sewer with permission from UT EH&S.

3.2.8 TEMPORARY STORAGE TANKS

- 3.2.8.1 Must be located in a bermed containment area. The berm must be a minimum 3 feet in all directions, and the height of the berm must contain the maximum contents of the largest tank plus 8 inches (approximately 110% of the tank capacity). The containment area is constructed by beginning with a 2-inch sand pad, and then covered with 6-mil plastic or rubber sheeting. The sheeting is then covered with another 2-inch layer of sand. The plastic sheeting is secured to the outer berm.
- 3.2.8.2 Storage tanks are to be placed no closer than 50 feet from a building or property line.
- 3.2.8.3 If using tanks with a gravity feed setup, the containment must be of sufficient size to be able to contain the tank if it should fall over.
- 3.2.8.4 There must be a fusible link at the valve that will shut off the flow to the hose in the event of a fire.
- 3.2.8.5 There must be sufficient cover for the tank and the containment area to prevent potential storm water runoff.
- 3.2.8.6 The area within the containment area is to be kept free and clear of spills; if a spill occurs, the sand is to be removed and replace with a fresh layer of sand.
- 3.2.8.7 The storage tank containment area is to be removed from the site once it has been determined that it will no longer be used on the construction site.

3.2.9 DIVERSION DIKE

- 3.2.9.1 Diversion dikes shall be formed and shaped using compacted fill, and shall not intercept runoff from more than 10 acres. The dike shall have a minimum top width of 24 inches, and a minimum height of 18 inches. Soil shall have side slopes of 3:1 or flatter, and shall be placed in 8-inch lifts. Compact soil to 95% standard proctor density. Where protected slopes exceed 2 percent, the uphill side of diversion dike shall be stabilized with

crushed stone or erosion control matting to a distance of not less than 7 feet from toe of dike. The channel that is formed by the diversion dike must have positive drainage for its entire length to a stabilized outlet, such as a rock berm, sandbag berm, or stone outlet structure. Storm water shall not be allowed to overflow the top of diversion dike at any point other than the stabilized outlet.

3.2.9.2 Maintain the diversion dike in a condition that allows the storm water runoff to be diverted away from exposed slopes. Repair any failures at top of dike and remove sediment as necessary behind the dike to allow positive drainage to a stabilized outlet.

3.2.9.3 Remove diversion dike when the expose slopes being protected are stabilized with vegetation or other permanent cover.

3.2.10 INTERCEPTOR SWALE

3.2.10.1 An interceptor swale shall be implemented to prevent on or off-site storm water from entering a disturbed area, or prevent sediment-laden runoff from leaving the site or disturbed area. The interceptor swale shall be excavated as required by the SWPPP drawings, with side slopes of 3:1 or flatter. This shall include all labor and equipment associated with the installation and maintenance of the swale as shown on the construction documents. Constructed swale may be v-shaped or trapezoidal with a flat bottom, depending on the volume of water being channeled. Sediment laden runoff from swale shall be directed to a stabilized outlet or sediment-trapping device. Flow line of swale shall have a continuous fall for its entire length and shall not be allowed to overflow at any other points along its length.

3.2.10.2 Maintain interceptor swale in a condition that allows the storm water runoff to be channeled away from disturbed areas. Remove sediment in swale as necessary to maintain positive drainage to a stabilized outlet.

3.2.10.3 Fill in or remove swale after the disturbed area/s being protected is completely stabilized as specified.

3.2.11 EROSION CONTROL MATTING

3.2.11.1 Remove all rocks, debris, dirt clods, roots, and any other obstructions which would prevent the matting from lying in direct contact with the soil. 6 inch by 6 inch anchor trenches shall be dug along the entire perimeter of the installation. Bury matting in trenches, backfill and compact. Fasten matting to the soil using 10-gauge wire staples, 6 inches in length and 1 inch wide. Use a minimum of 1 staple per 4 square feet of matting, and at 12 inches on center along all edges. Install parallel to flow of water and overlap joining strips a minimum of 12 inches.

3.2.11.2 Maintain erosion control matting by repairing any bare spots. Missing or

loosened matting shall be promptly replaced or re-anchored.

- 3.2.11.3 Remove matting where protection is no longer required. In areas where permanent vegetation is established along with matting, matting can be left in place permanently.

3.2.12 MULCHES

- 3.2.12.1 Apply specified mulches in areas identified on the SWPPP, to a depth of 3 inches or as otherwise specified on the SWPPP drawings.

3.2.13 BPM Details

- 3.2.13.1 Refer to Exhibits for the following BMP details:
- Exhibit A -- Area Inlet Detail
 - Exhibit B -- Curb Inlet Detail
 - Exhibit C -- Rock Berm Detail
 - Exhibit D -- Silt Fence Detail
 - Exhibit E -- Triangular Dike Detail
 - Exhibit F -- Stabilized Construction Exit
 - Exhibit G -- Concrete Truck Washout

3.3 INSPECTIONS AND RECORD KEEPING

- 3.3.1 Contractor shall inspect all BMPs on 7-day intervals. Coordinate inspections with UTHSCH CI, who is also required by TPDES to regularly inspect the site. Use standard Owner Inspection forms (see form in Part 4 of this Section) for each inspection. Record all deficiencies of site controls, and take appropriate action to correct any deficiencies recorded. Exception is rock berms located in a streambed. Any rock berm located in a streambed shall be inspected on a daily basis. Keep records of inspections current and on file, available for review by EPA, TCEQ, MS4 Operator Representative and/or Owner's Representative.
- 3.3.2 Contractor shall keep records of all Contractor inspections on file with SWPPP book at project site, and make available for review by Owner's Representative or EPA, TCEQ or MS4 Operator officials requesting review of SWPPP inspection records. One copy of each inspection report shall be delivered to the CI and the RCM office.
- 3.3.3 Contractor shall keep records of all major grading and stabilization activities on file with the SWPPP book at the project site and make available for review by Owner's representative, EPA, TCEQ, or MS4 Operator officials requesting review of the SWPPP.
- 3.3.4 Contractor shall retain copies of all inspection records and the Major Grading and Stabilization Log along with SWPPP book for 3 years from NOT date per TCEQ

regulations.

3.4 MAINTENANCE

- 3.4.1 All erosion and sediment control measures and other protective measures identified in the SWPPP must be maintained in effective operating condition. If through inspections the permittee determines that BMPs are not operating effectively, maintenance must be performed before the next anticipated storm event or as necessary to maintain the continued effectiveness of storm water controls. If maintenance prior to the next anticipated storm event is impracticable, maintenance must be scheduled and accomplished as soon as practicable. Erosion and sediment controls that have been intentionally disabled, run over, removed or otherwise rendered ineffective must be replaced or corrected immediately upon discovery.

3.5 Waste Disposal

- 3.5.1 Contractor is responsible for proper disposal of hazardous materials. Hazardous wastes (such as flammable petroleum products and solvents, thinners) and materials contaminated with hazardous wastes are considered regulated wastes, and should be containerized for transport and disposal by a permitted company in accordance with applicable laws and regulations.
- 3.5.2 Any trash or debris must be contained on site and disposed of in a recycling bin or waste receptacle in accordance with applicable laws and regulations to prevent wind or rain from carrying it off-site into a storm drain. Non-hazardous solid wastes such as general construction debris may be recycled or disposed of in the trash container. Never dispose of liquid wastes of any kind in University dumpsters.

PART 4 - SAMPLE FORMS

The following forms or sketches are to be used by the Contractor in the execution of the work in this Section, in compliance with TPDES requirements and the SWPPP.

- UT System UTHSCH SWPPP Project Start-up
- Major Grading and Stabilization Log
- SWPPP Posting Sign for Main Construction Entrance for large construction site 5 acres or greater
- SWPPP Posting Sign for Main Construction Entrance for small construction site 1 to less than 5 acres

Contact the Owner's representative for electronic copies of these forms to be used in the execution of work in this section:

- TCEQ TPDES Notice of Intent (NOI)

- TCEQ TPDES CSN (Large CSN or Small CSN)
- TCEQ TPDES Notice of Termination (NOT)
- UT System UTHSCH Notice of Termination (UTHSCH NOT)
- Shared SWPPP Acceptance Certification form
- UT System UTHSCH SWPPP Inspection form

END OF SECTION 01 57 23



The University of Texas
Health Science Center at Houston

The University of Texas System

Office of Facilities Planning and Construction
702 Colorado Street, Suite 4.100 Austin, Texas 78701
(512) 499-4600 FAX (512) 499-4604

SWPPP Project Start-up

Contractors must meet 4 TPDES requirements before soil-disturbing activities can commence on UTHSCH construction projects. This form provides the Contractor and Owner an acceptance of compliance with initial BMPs and required paperwork for commencement of work on the project site.

The Contractor is to initial items that are certified as complete and then review for concurrence with the Owner's Designated Representative.

1 BMPs applicable to this project have been inspected to ensure correct placement in accordance with the SWPPP and for proper installation according to specifications.

Initial by Contractor

Initial by UTHSCH CI

2 The SWPPP is approved and on site.

Initial by Contractor

Initial by UTHSCH CI

3 The TCEQ NOI and UTHSCH Posting Notice forms (and permits if received) or the TCEQ CSNs are complete and posted for all permittees at the main entrance to the project site.

Initial by Contractor

Initial by UTHSCH CI

4 Inspector qualifications and letter of delegation of authority are inserted in the SWPPP.

Initial by Contractor

Initial by UTHSCH CI

Having met the above requirements and in recognition of prior receipt of Notice to Proceed, the Contractor is authorized to commence work on site.

Contractor

UTHSCH Project #_

UTHSCH Resident Construction
Manager

Date: _

Sign for Large Construction Site

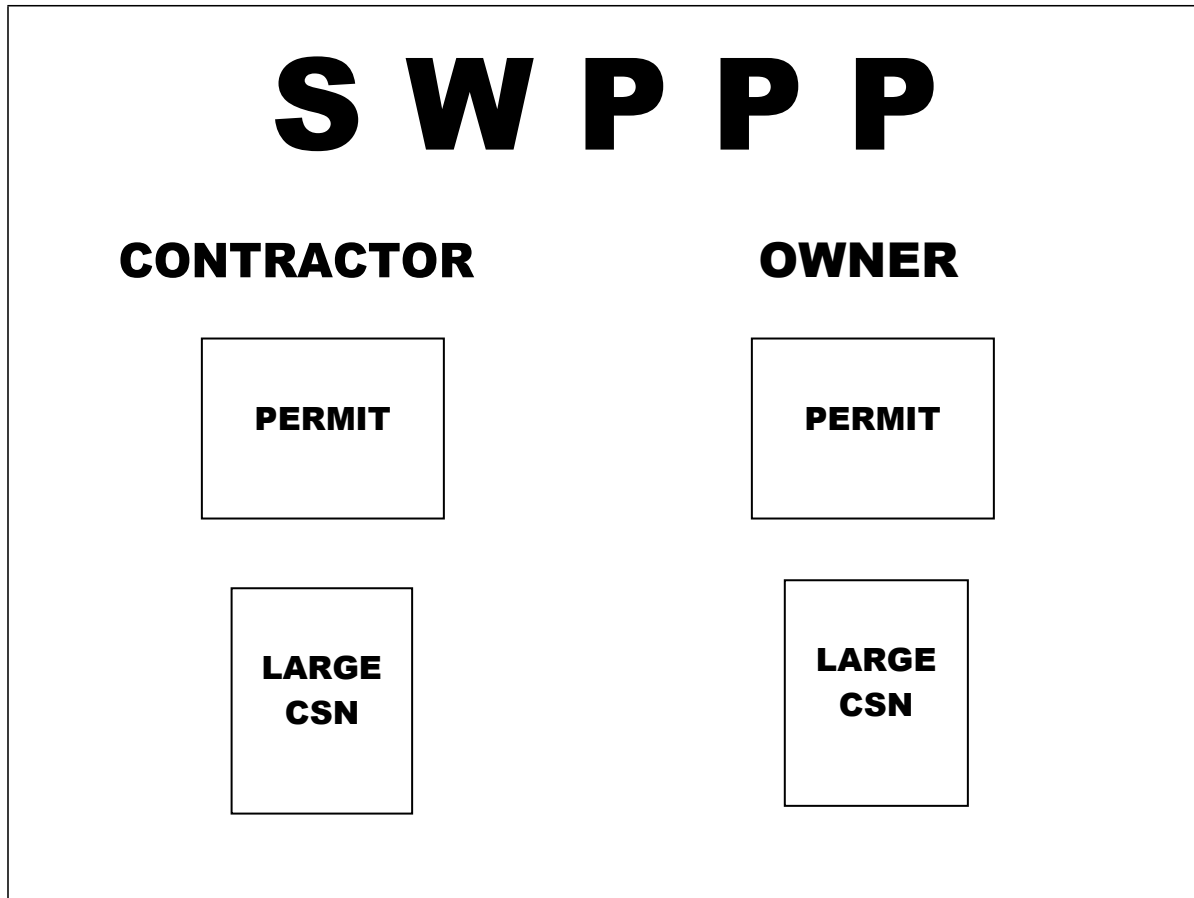

MINIMUM SIGN SPECIFICATIONS: 5 Acre or Greater Sites

SIGN - Exterior grade 3/4" plywood, cut 4' x 4', with red painted letters, background painted white - **DISPLAY ON CONSTRUCTION FENCE AT MAIN ENTRANCE TO PROJECT SITE.**

S W P P P - 10-inch painted letters, 3 inches from top of sign, centered

CONTRACTOR OWNER - 3 inch painted letters, 4 inches below SWPPP letters, centered on each half of sign

PERMIT, CSN - 8-1/2 X 11 TCEQ forms, laminated beyond edges of documents, stapled to plywood.

Sign for Small Construction Site

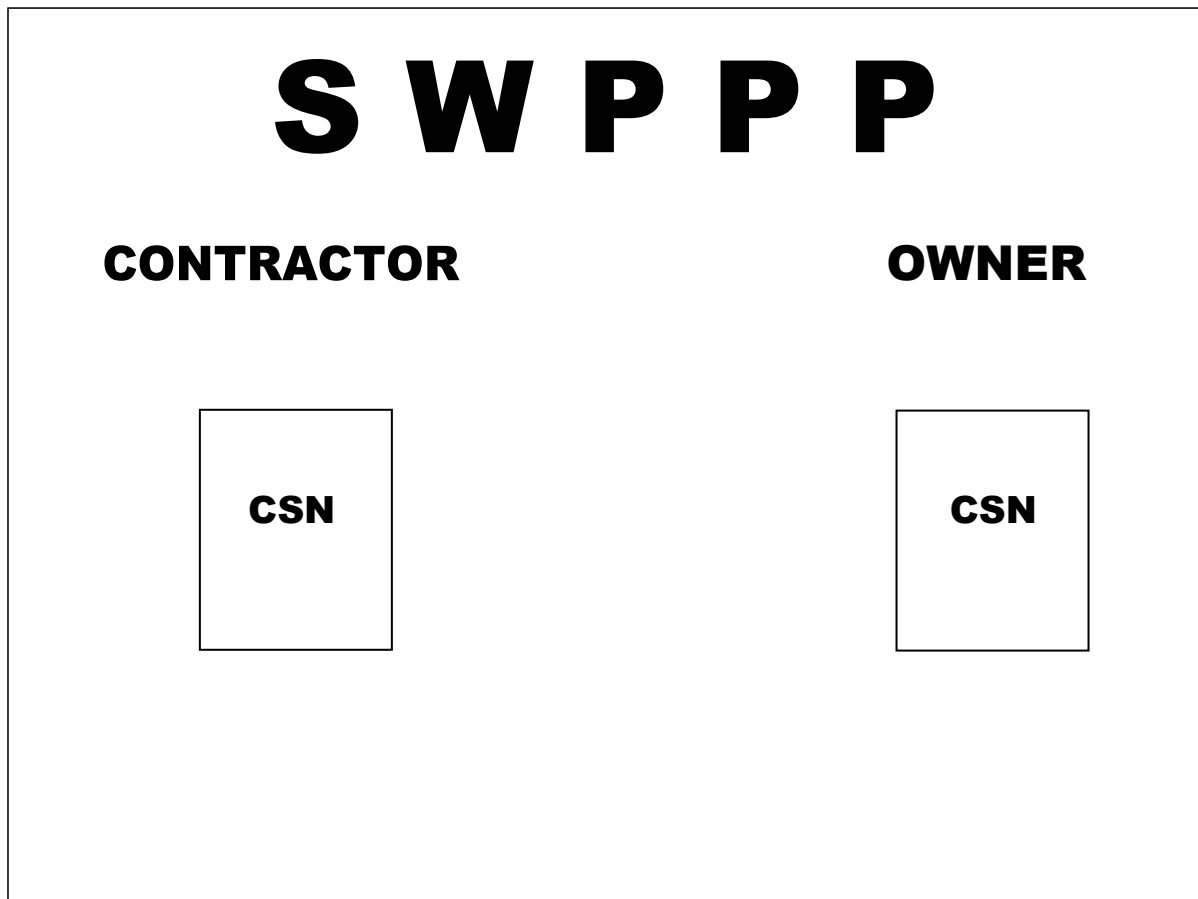

MINIMUM SIGN SPECIFICATIONS: 1 to Less than 5 Acre Sites

SIGN - Exterior grade $\frac{3}{4}$ " plywood, cut 4' x 4', with red painted letters, background painted white - **DISPLAY ON CONSTRUCTION FENCE AT MAIN ENTRANCE TO PROJECT SITE.**

S W P P P - 10-inch painted letters, 3 inches from top of sign, centered

CONTRACTOR **OWNER** - 3-inch painted letters, 4 inches below SWPPP letters, centered on each half of sign

CONSTRUCTION SITE NOTICE - 8-1/2 X 11 TCEQ forms, laminated beyond edges of documents, stapled to plywood.

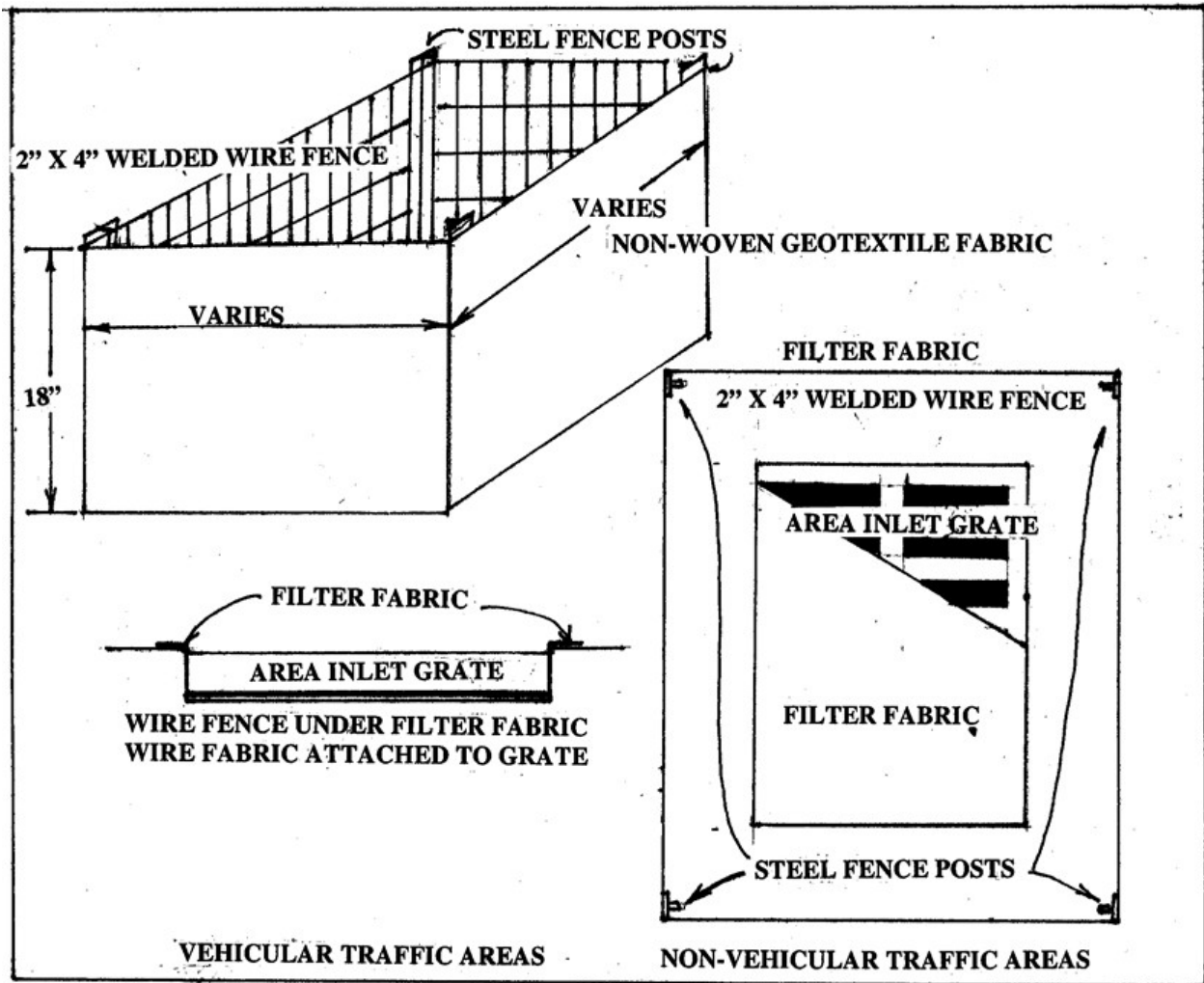
EXHIBIT A
Area Inlet Detail

1. INSTALL STEEL POSTS THAT SUPPORT THE SILT FENCE AT EACH CORNER, AND ALSO BETWEEN CORNERS IF THE DISTANCE IS GREATER THAN 6 FEET BETWEEN CORNER POSTS.
2. USE SILT FENCE DETAIL FOR INSTALLATION OF THE SILT FENCE AROUND THE AREA INLET.
3. LIFT THE METAL AREA INLET GRATE, WRAP THE FILTER FABRIC AROUND IT, AND THEN REPLACE THE GRATE.
4. IN VEHICULAR TRAFFIC AREAS, LIFT THE METAL GRATE OUT AND PLACE WIRE FENCE MATERIAL UNDER IT WITH FILTER FABRIC PLACED BETWEEN THE GRATE AND THE WIRE FENCE. THEN ATTACH THE WIRE FENCE TO THE GRATE.
5. REMOVE ACCUMULATED SILT WHEN THE FILTER FABRIC OVE THE GRATE COMPLETELY COVERS THE GRATE AREA AND THE SILT AROUND THE SILT FENCE REACHES A HEIGHT OF 6 INCHES.
6. REMOVE AREA INLET PROTECTION WHEN THE SITE IS COMPLETELY STABILIZED.

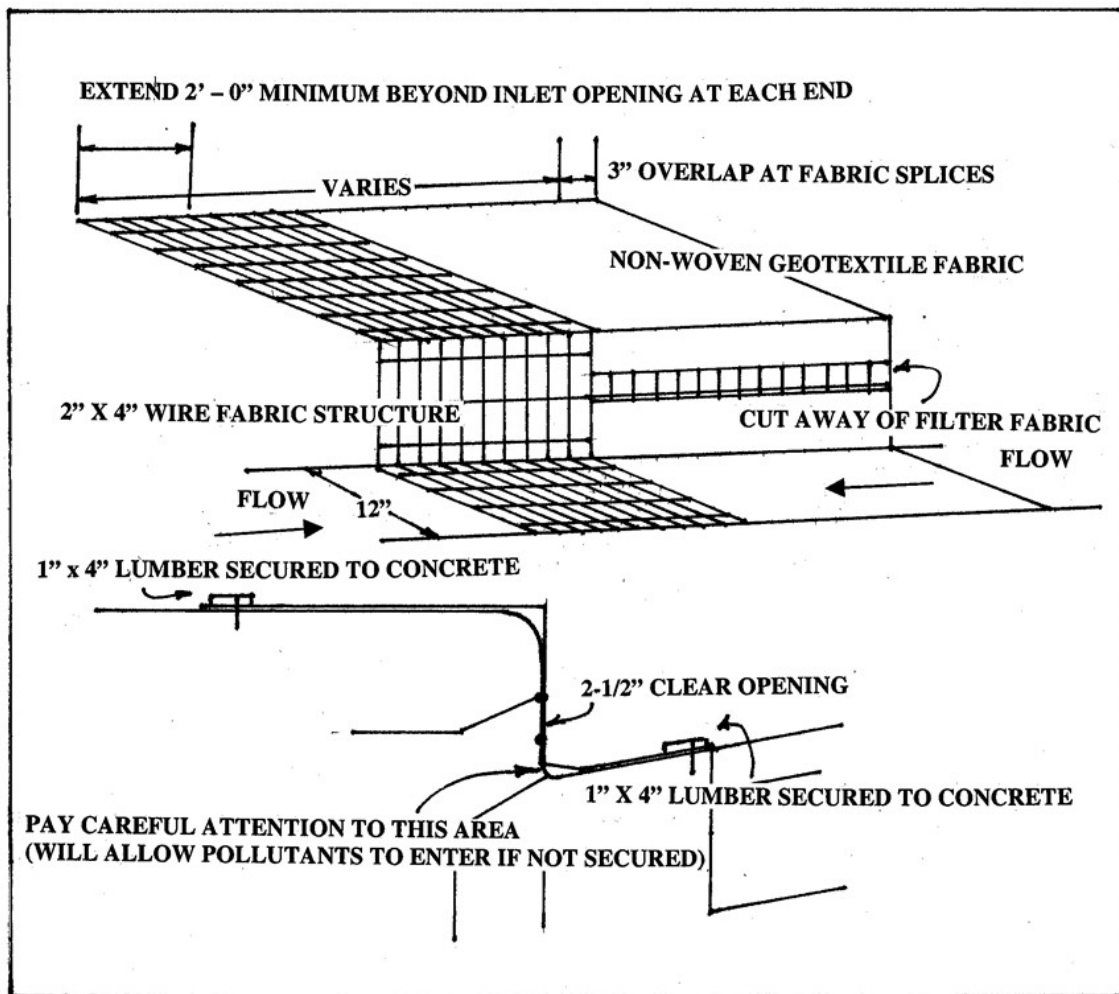
EXHIBIT B
Curb Inlet Detail

1. WHERE MINIMUM CLEARANCES CAUSE TRAFFIC TO DRIVE IN THE GUTTER, USE 1" BY 4" LUMBER SECURED WITH CONCRETE NAILS 3 FEET ON CENTER NAILED INTO THE CONCRETE. IF THERE IS PEDESTRIAN TRAFFIC ONLY, THE USE OF 20# GRAVEL BAGS TO SECURE MATERIAL IS PERMITTED.
2. REMOVE SECTION OF FILTER FABRIC AS SHOWN IN THIS DETAIL. SECURE FABRIC TO WIRE BACKING WITH CLIPS OR HOG RINGS AT THIS LOCATION.
3. INSPECT DAILY AND REMOVE SILT ACCUMULATION WHEN THE DEPTH REACHES 2 INCHES.
4. MONITOR THE PERFORMANCE OF THE INLET PROTECTION DURING EACH RAINFALL EVENT AND REMOVE PROTECTION IMMEDIATELY IF THE STORM WATER BEGINS TO OVERTOP THE CURB.
5. REMOVE ACCUMULATED SILT WHEN THE FILTER FABRIC OVER THE GRATE COMPLETELY COVERS THE GRATE AREA AND THE SILT AROUND THE SILT FENCE REACHES A HEIGHT OF 6 INCHES.
6. REMOVE INLET PROTECTION AS SOON AS THE SOURCE OF SEDIMENT IS STABILIZED.

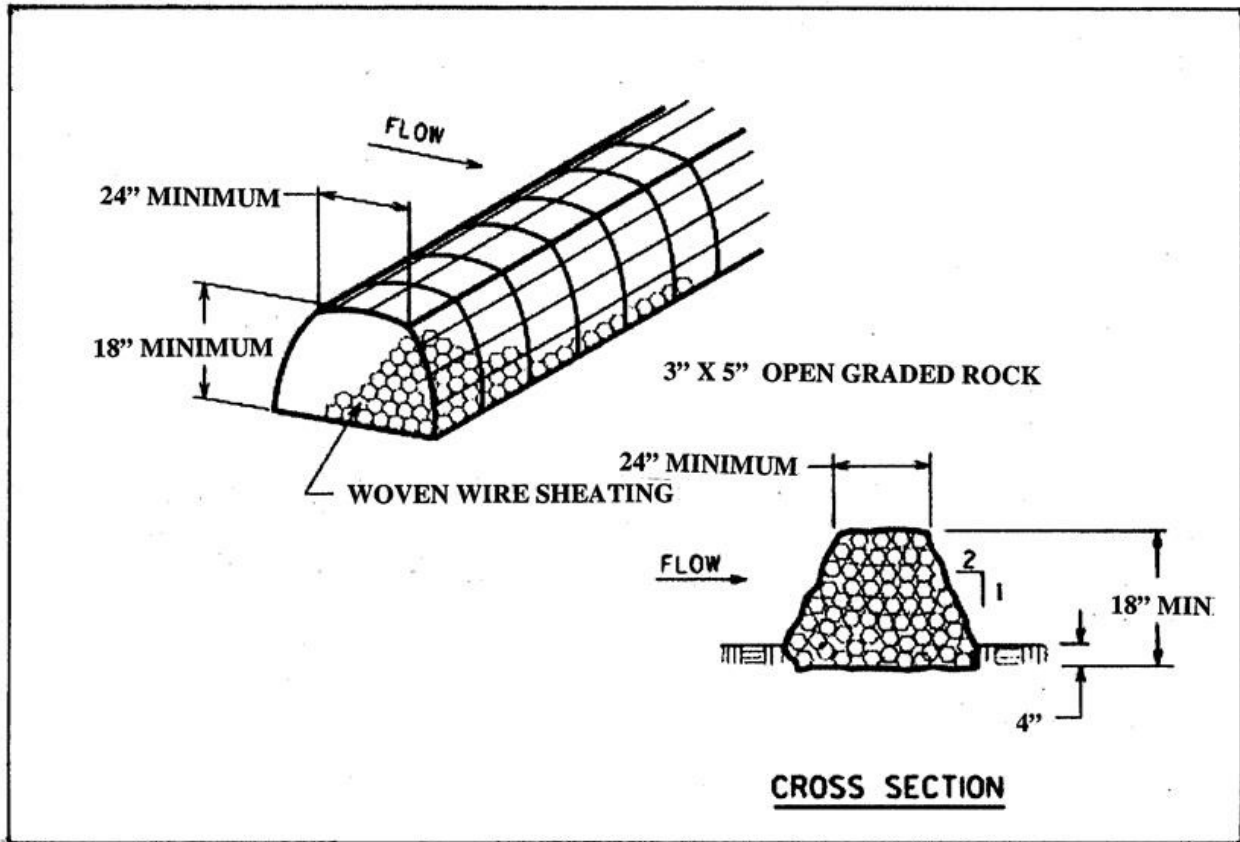
EXHIBIT C
Rock Berm Detail

1. USE ONLY OPEN GRADED 4" X 8" ROCK FOR STREAM FLOW CONDITIONS. USE 3" X 5" OPEN GRADED ROCK FOR OTHER CONDITIONS.
2. SECURE THE ROCK BERM WITH A WOVEN WIRE SHEATHING HAVING A MAXIMUM 1 INCH OPENING AND A MINIMUM 20-GAUGE WIRE DIAMETER. ANCHOR ROCK BERMS IN CHANNEL APPLICATIONS FIRMLY INTO THE SUBSTRATE A MINIMUM OF 6 INCHES WITH TEE POSTS OR WITH #5 OR #6 REBAR WITH A MAXIMUM SPACING OF 48 INCHES ON CENTER.
3. INSPECT THE ROCK BERM WEEKLY. REPLACE THE STONE AND/OR FABRIC CORE-WOVEN SHEATHING WHEN THE STRUCTURE CEASES TO FUNCTION AS INTENDED DUE TO SILT ACCUMULATION AMONG THE ROCKS, WASHOUT, CONSTRUCTION TRAFFIC, ETC.
4. WHEN SILT REACHES A DEPTH EQUAL TO ONE-THIRD THE HEIGHT OF THE BERM OR 6 INCHES, WHICHEVER IS LESS, REMOVE THE SILT AND DISPOSE OF ON AN APPROVED SITE AND IN A MANNER THAT WILL NOT CREATE A SILTRATION PROBLEM.
5. INSPECT SEVERE SERVICE ROCK BERMS DAILY, AND REMOVE SILT WHEN ACCUMULATION REACHES 6 INCHES.
6. WHEN THE SITE IS COMPLETELY STABILIZED, REMOVE THE ROCK BERM AND ACCUMULATED SILT AND DISPOSE OF IN AN APPROVED MANNER.

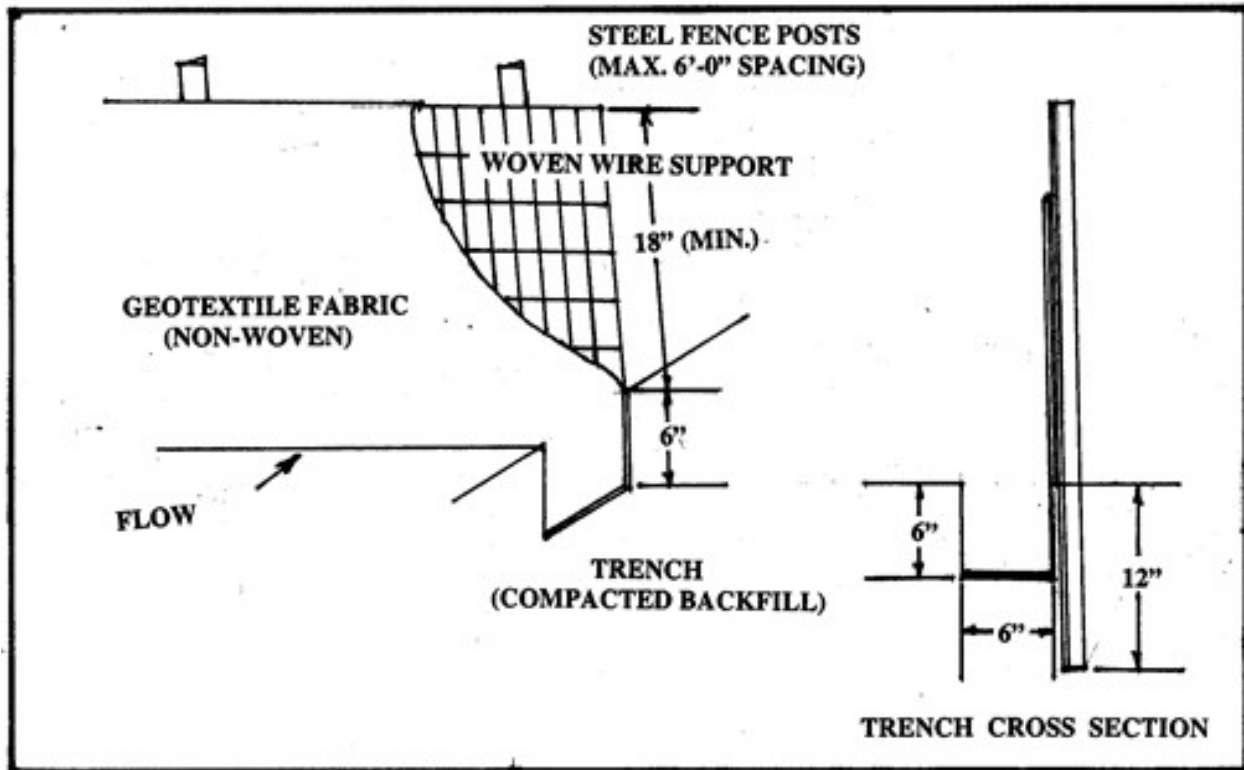
EXHIBIT D
Silt Fence Detail

1. INSTALL STEEL POSTS THAT SUPPORT THE SILT FENCE ON A SLIGHT ANGLE TOWARD THE ANTICIPATED RUNOFF SOURCE. POSTS MUST BE EMBEDDED A MINIMUM OF 12 INCHES.
2. TRENCH IN THE TOE OF THE SILT FENCE WITH A SPADE OR MECHANICAL TRENCHER SO THAT THE DOWNSLOPE FACE OF THE TRENCH IS FLAT AND PERPENDICULAR TO THE LINE OF THE FLOW. WHERE FENCE CAN NOT BE TRENCHED INTO THE SURFACE, (E.G., PAVEMENT), WEIGHT THE FABRIC DOWN WITH ROCK OR 1" X 4" LUMBER SECURELY FASTENED TO THE SURFACE. PLACE ON THE UPSTREAM SIDE TO PREVENT FLOW UNDER THE FENCE.
3. THE TRENCH MUST BE A MINIMUM OF 6 INCHES DEEP AND 6 INCHES WIDE TO ALLOW FOR THE FILTER FABRIC TO BE LAID IN THE GROUND AND BACKFILLED WITH COMPACTED MATERIAL.
4. FASTEN THE FILTER FABRIC SECURELY TO THE WOVEN WIRE BACKING, AND IN TURN FASTEN IT SECURELY TO THE STEEL FENCE POST.
5. REMOVE ACCUMULATED SILT WHEN IT REACHES A DEPTH OF 6 INCHES, DISPOSE OF THE SILT ON AN APPROVED SITE AND IN SUCH A MANNER THAT IT WILL NOT CONTRIBUTE TO ADDITIONAL SILTRATION.
6. INSPECT THE SILT FENCE WEEKLY AND REPAIR OR REPLACE PROMPTLY IF NEEDED.
7. WHEN THE SITE IS COMPLETELY STABILIZED, REMOVE THE SILT FENCE.

EXHIBIT E

Triangular Dike Detail

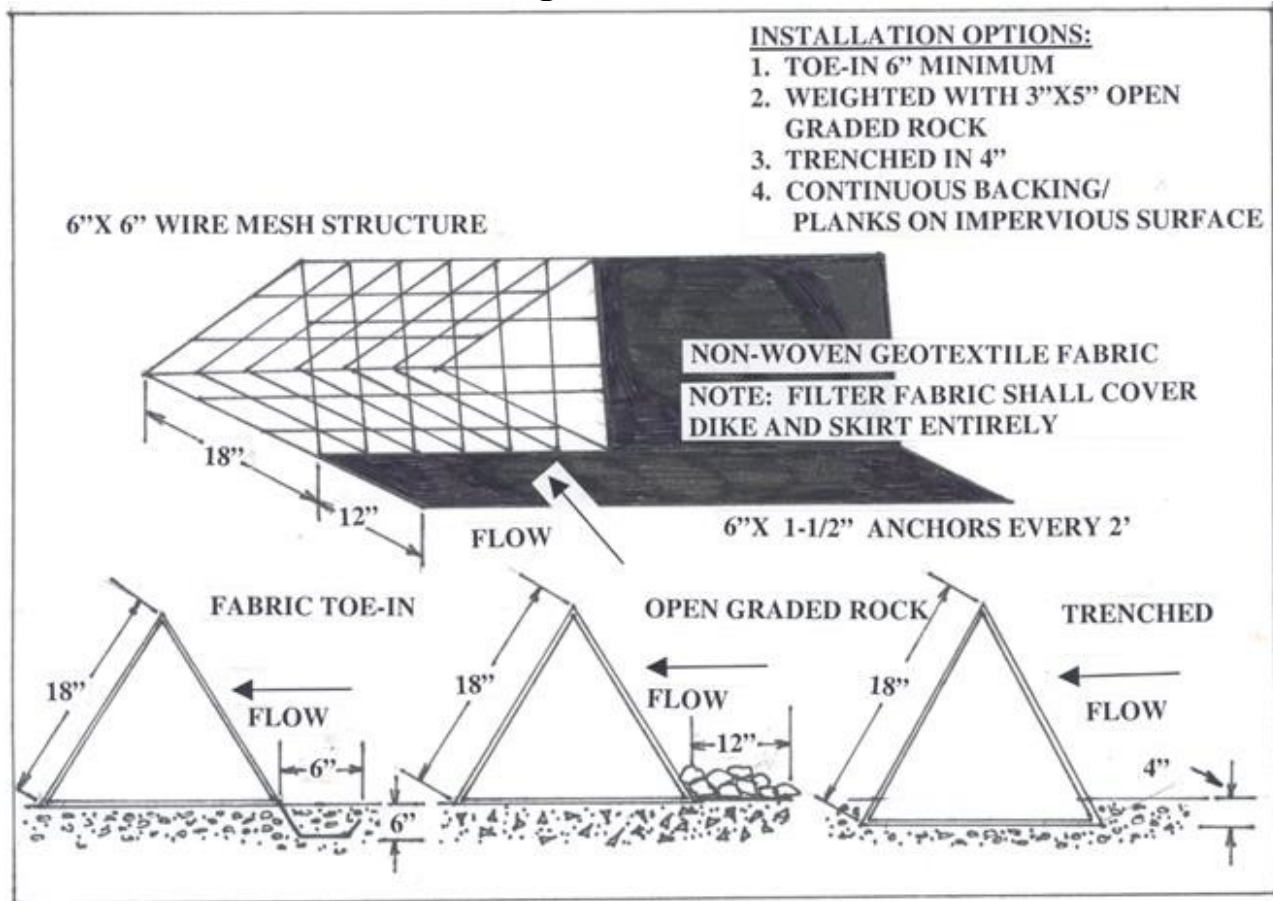

1. PLACE DIKES IN A ROW WITH EACH END TIGHTLY ABUTTING THE ADJACENT DIKE.
2. THE FABRIC COVER AND SKIRT SHALL BE A CONTINUOUS WRAPPING OF NON-WOVEN GEOTEXTILE. THE SKIRT SHALL BE A CONTINUOUS EXTENSION OF THE FABRIC ON THE UPSTREAMFACE.
3. WEIGHT THE SKIRT WITH A CONTINUOUS LAYER OF 3" x 5" OPEN GRADED ROCK, 1" x 4" SECURELY FASTENED LUMBER, OR TOED-IN 6 INCHES WITH MECHANICALLY COMPACTED MATERIAL. OTHERWISE, TRENCH IT IN 4 INCHES IN DEPTH.
4. ANCHOR DIKES AND SKIRT SECURELY IN PLACE USING 6 INCH WIRE STAPLES ON 2 FOOT CENTERS ON BOTH EDGES OF SKIRT, OR STAKE USING 3/8 INCH REBAR WITH TEE ENDS.
5. LAP FILTER MATERIAL OVER ENDS 6 INCHES TO COVER DIKE TO DIKE JOINTS. FASTEN JOINTS WITH GALVANIZED HOG RINGS.
6. THE DIKE STRUCTURE SHALL BE 6-GAUGE 6" x 6" WIRE MESH, 18 INCHES ON A SIDE.
7. REMOVE ACCUMULATED SILT WHEN IT REACHES A DEPTH OF 6 INCHES, AND DISPOSE OF IT IN A MANNER THAT WILL NOT CAUSE ADDITIONAL SILTRATION.
8. INSPECT TRIDIKES WEEKLY AND REPAIR OR REPLACE PROMPTLY AS NEEDED.
9. AFTER THE SITE IS COMPLETELY STABILIZED, REMOVE THE DIKES AND ANY REMAINING SILT.

EXHIBIT F

Stabilized Construction Exit

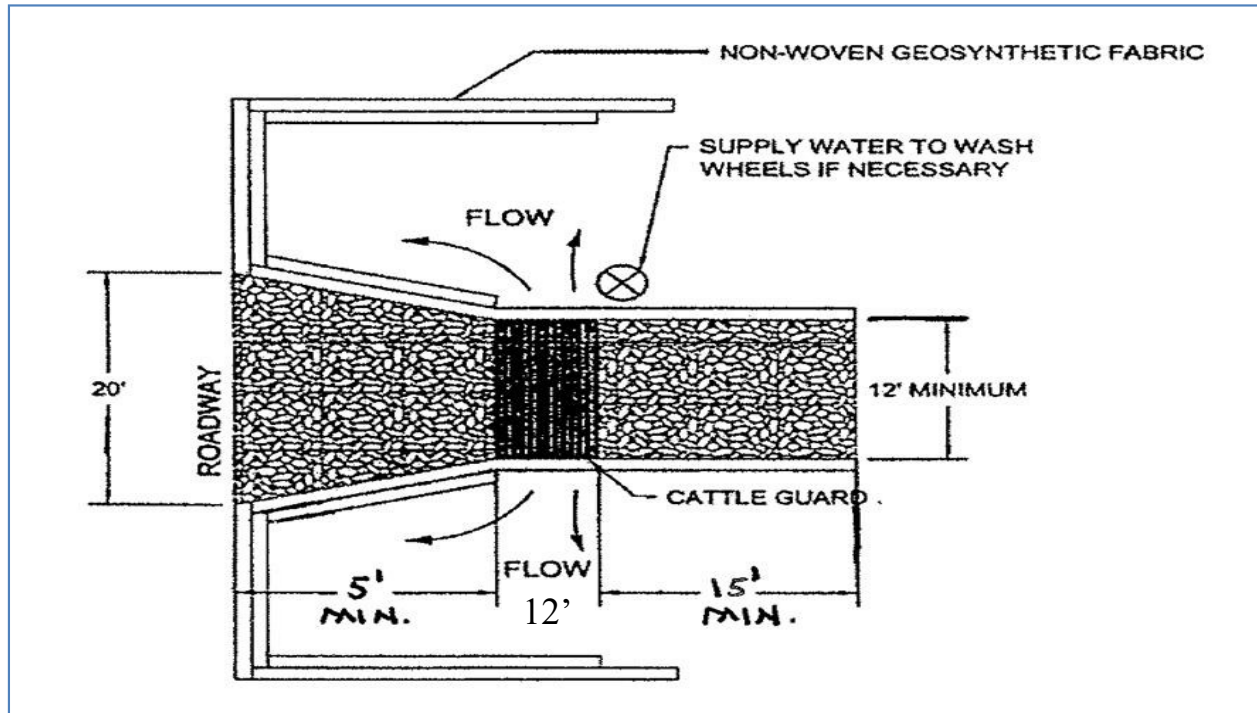

1. THE GRID CONSISTS OF PIPES OR TUBES WITH A MINIMUM DIAMETER OF 3 INCHES, AND SPACED SUCH THAT THERE IS A MINIMUM CLEAR DISTANCE OF 4 1/2 INCHES BETWEEN THEM. ELEVATE THE GRID ABOVE THE GROUND SURFACE A MINIMUM OF 8 INCHES TO ALLOW WATER, DEBRIS AND SOIL TO DRAIN.
2. THE GRID SHALL BE DESIGNED TO SUPPORT THE WEIGHT OF ANY AND ALL VEHICLES ENTERING AND LEAVING THE CONSTRUCTION SITE.
3. THE GRID SHALL BE FIRMLY PLACED IN THE GROUND AT THE EXIT, AND SHALL BE OF SUFFICIENT LENGTH THAT THE AGITATION WILL REMOVE THE SOIL FROM THE TIRES, OR A MINIMUM OF 12 FEET.
4. AT THE STREET SIDE APPROACH OF THE GRID, THERE SHALL BE AN IMPERVIOUS SURFACE OR IT SHALL CONSIST OF 3" x 5" ANGULAR CRUSHED STONE/ROCK 5 FEET IN LENGTH MINIMUM, AND 8 INCHES DEEP, MINIMUM. ON THE JOB SITE SIDE OF THE GRID, THERE SHALL BE 3" x 5" ANGULAR CRUSHED STONE/ROCK 15 FEET IN LENGTH, MINIMUM, 8 INCHES DEEP, MINIMUM. THE STEEL GRID WILL BE BETWEEN THE STREET SIDE APPROACH AND THE JOB SITE CRUSHED STONE/ROCK. ALL CRUSHED STONE/ROCK SHALL HAVE FILTER FABRIC PLACED BENEATH IT.
5. THE STEEL GRID AREA SHALL BE USED AS THE TIRE WASH AREA. WHEN TIRE WASH IS IN USE (RAINY OR MUDDY DAYS), THE AREA SHALL BE MANNED AND THE TIRES SHALL BE WASHED USING A HIGH PRESSURE HOSE/NOZZLE.
6. THE AREA BENEATH THE GRID SHALL BE SLOPED SUCH THAT DEBRIS, SOIL AND WATER SHALL BE DIVERTED BACK ON TO THE CONSTRUCTION SITE OR TO A SEDIMENT BASIN. NO WATER, SOIL OR DEBRIS SHALL LEAVE THE CONSTRUCTION SITE, AND THE RESULTING DISCHARGE SHALL BE DISPOSED OF PROPERLY.

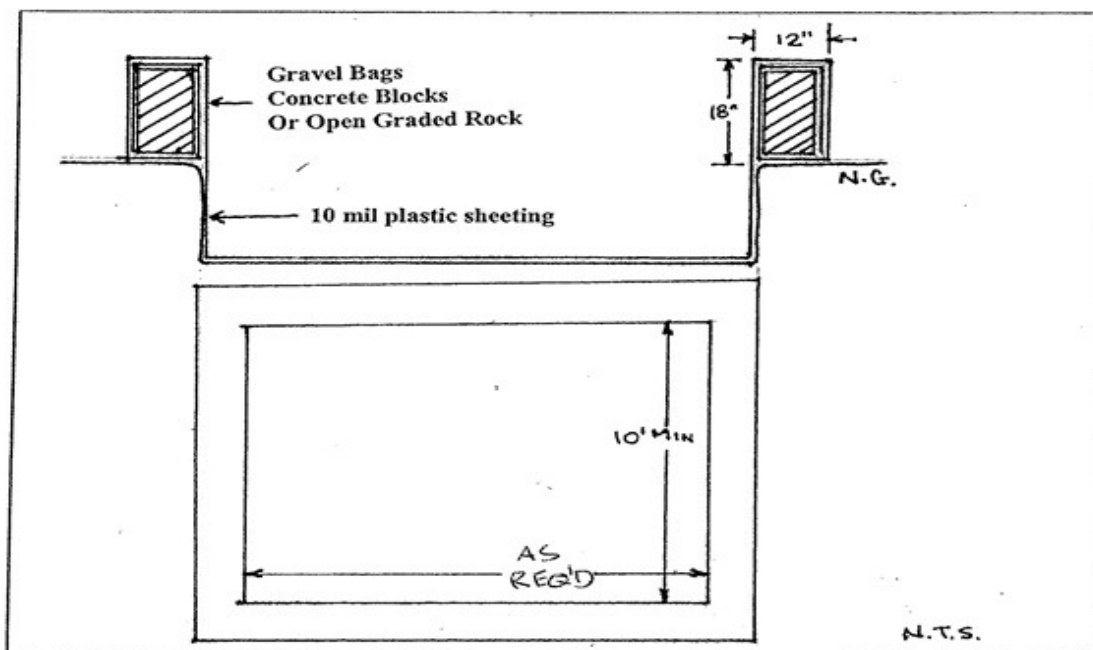
EXHIBIT G
Concrete Truck Washout

1. THE EXCAVATION FOR THE CONCRETE TRUCK WASHOUT SHALL BE A MINIMUM OF 10 FEET WIDE AND OF SUFFICIENT LENGTH AND DEPTH TO ACCOMMODATE 7 GALLONS OF WASHOUT WATER AND CONCRETE PER TRUCK PER DAY AND/OR 50 GALLONS OF WASHOUT WATER AND CONCRETE PER PUMP TRUCK PER DAY.
2. IN THE EVENT THAT THE CONCRETE TRUCK WASHOUT IS CONSTRUCTED ABOVE GROUND, IT SHALL BE 10 FEET WIDE AND 10 FEET LONG, WITH THE SAME REQUIREMENTS FOR CONTAINMENT AS DESCRIBED IN ITEM 1.
3. THE CONTAINMENT AREA SHALL BE LINED WITH 10 MIL PLASTIC SHEETING WITHOUT HOLES OR TEARS. WHERE THERE ARE SEAMS, THESE SHALL BE SECURED ACCORDING TO MANUFACTURERS' DIRECTIONS.
4. THE BERM CONSISTING OF GRAVEL BAGS, CONCRETE BLOCKS OR OPEN GRADED ROCK SHALL BE NO LESS THAN 18 INCHES HIGH AND NO LESS THAN 12 INCHES WIDE.
5. THE PLASTIC SHEETING SHALL BE OF SUFFICIENT SIZE SO THAT IT WILL OVERLAP THE TOP OF THE CONTAINMENT AREA AND BE WRAPPED AROUND THE GRAVEL BAGS, CONCRETE BLOCKS OR OPEN GRADED ROCK AT LEAST 2 TIMES.
6. THE GRAVEL BAGS OR CONCRETE BLOCKS SHALL BE PLACED ABUTTING EACH OTHER TO FORM A CONTINUOUS BERM AROUND THE OUTER PERIMETER OF THE CONTAINMENT AREA.
7. THE WASHOUT MATERIAL IN THE CONTAINMENT AREA SHALL NOT EXCEED 50% OF CAPACITY AT ANY ONE TIME.
8. SOLIDS SHALL BE REMOVED FROM CONTAINMENT AREA AND DISPOSED OF PROPERLY. ANY DAMAGE TO THE PLASTIC SHEETING SHALL BE REPAIRED OR SHEETING REPLACED BEFORE THE NEXT USE.



Formatted: Centered

**SECTION 01 60 00
PRODUCT REQUIREMENTS**

PART 1 GENERAL

1.01 SECTION INCLUDES

- A. Re-use of existing products.
- B. Transportation, handling, storage and protection.
- C. Product option requirements.
- D. Substitution limitations and procedures.
- E. Procedures for Owner-supplied products.
- F. Maintenance materials, including extra materials, spare parts, tools, and software.

1.02 RELATED REQUIREMENTS

- A. Section 01 40 00 - Quality Requirements: Product quality monitoring.
- B. Section 01 61 16 - Volatile Organic Compound (VOC) Content Restrictions: Requirements for VOC-restricted product categories.

1.0203 SUBMITTALS

- A. Proposed Products List: Submit list of major products proposed for use, with name of manufacturer, trade name, and model number of each product.
 - 1. Submit within 15 days after date of Agreement.
 - 2. For products specified only by reference standards, list applicable reference standards.
- B. Product Data Submittals: Submit manufacturer's standard published data. Mark each copy to identify applicable products, models, options, and other data. Supplement manufacturers' standard data to provide information specific to this Project.
- C. Shop Drawing Submittals: Prepared specifically for this Project; indicate utility and electrical characteristics, utility connection requirements, and location of utility outlets for service for functional equipment and appliances.
- D. Sample Submittals: Illustrate functional and aesthetic characteristics of the product, with integral parts and attachment devices. Coordinate sample submittals for interfacing work.
 - 1. For selection from standard finishes, submit samples of the full range of the manufacturer's standard colors, textures, and patterns.

PART 2 PRODUCTS

2.01 EXISTING PRODUCTS

- A. Do not use materials and equipment removed from existing premises unless specifically required or permitted by the Contract Documents.
- B. Unforeseen historic items encountered remain the property of the Owner; notify Owner promptly upon discovery; protect, remove, handle, and store as directed by Owner.
- C. Existing materials and equipment indicated to be removed, but not to be re-used, relocated, reinstalled, delivered to the Owner, or otherwise indicated as to remain the property of the Owner, become the property of the Contractor; remove from site.

2.02 NEW PRODUCTS

- A. Provide new products unless specifically required or permitted by the Contract Documents.
- B. DO NOT USE products having any of the following characteristics:
 - 1. Made outside the United States, its territories, Canada, or Mexico.
 - 2. Made using or containing CFC's or HCFC's.
 - 3. Made of wood from newly cut old growth timber.
 - 4. Containing lead, cadmium, asbestos.

Formatted: Tab stops: Not at 11.03"

Containing lead, cadmium, asbestos.

- C. Where all other criteria are met, Contractor shall give preference to products that:
 - 1. If used on interior, have lower emissions, as defined in Section 01 61 16.
 - 2. If wet-applied, have lower VOC content, as defined in Section 01 61 16.
 - 3. Are extracted, harvested, and/or manufactured closer to the location of the project.
 - 4. Have longer documented life span under normal use.
 - 5. Result in less construction waste.
 - 6. Are made of vegetable materials that are rapidly renewable.
 - 7. Are made of recycled materials.
 - 8. Have a published GreenScreen Chemical Hazard Analysis.

2.03 PRODUCT OPTIONS

- A. Products Specified by Reference Standards or by Description Only: Use any product meeting those standards or description.
- B. Products Specified by Naming One or More Manufacturers: Use a product of one of the manufacturers named and meeting specifications, no options or substitutions allowed.
- C. Products Specified by Naming One or More Manufacturers with a Provision for Substitutions: Submit a request for substitution for any manufacturer not named.

2.04 MAINTENANCE MATERIALS

- A. Furnish extra materials, spare parts, tools, and software of types and in quantities specified in individual specification sections.
- B. Deliver to Project site; obtain receipt prior to final payment.

PART 3 EXECUTION

3.01 SUBSTITUTION PROCEDURES

- A. Substitutions will only be considered when a product becomes unavailable through no fault of the Contractor.
- B. Document each request with complete data substantiating compliance of proposed substitution with Contract Documents.
- C. A request for substitution constitutes a representation that the submitter:
 - 1. Has investigated proposed product and determined that it meets or exceeds the quality level of the specified product.
 - 2. Agrees to provide the same warranty for the substitution as for the specified product.
 - 3. Agrees to coordinate installation and make changes to other Work that may be required for the Work to be complete with no additional cost to Owner.
 - 4. Waives claims for additional costs or time extension that may subsequently become apparent.
 - 5. Agrees to reimburse Owner and Architect for review or redesign services associated with re-approval by authorities.
- D. Substitutions will not be considered when they are indicated or implied on shop drawing or product data submittals, without separate written request, or when acceptance will require revision to the Contract Documents.
- E. Substitution Submittal Procedure (for use when a product becomes unavailable through no fault of the Contractor):
 - 1. Obtain and use Construction Specifications Institute (CSI) Form 13.1A when submitting a substitution request.
 - 2. Submit three copies of request for substitution for consideration. Limit each request to one proposed substitution. A single electronic copy is acceptable in lieu of the three paper copies when physical samples are not required.
 - 3. Submit shop drawings, product data, and certified test results attesting to the proposed product equivalence. Burden of proof is on proposer.
 - 4. Substitutions will not be considered if the substitution submittal procedure is not followed.

5. Architect will notify Contractor in writing of decision to accept or reject request.

3.02 OWNER-SUPPLIED PRODUCTS

- A. Owner's Responsibilities:
 1. Arrange for and deliver Owner reviewed shop drawings, product data, and samples, to Contractor.
 2. Arrange and pay for product delivery to site.
 3. On delivery, inspect products jointly with Contractor.
 4. Submit claims for transportation damage and replace damaged, defective, or deficient items.
 5. Arrange for manufacturers' warranties, inspections, and service.
- B. Contractor's Responsibilities:
 1. Review Owner reviewed shop drawings, product data, and samples.
 2. Receive and unload products at site; inspect for completeness or damage jointly with Owner.
 3. Handle, store, install and finish products.
 4. Repair or replace items damaged after receipt.

3.03 TRANSPORTATION AND HANDLING

- A. Package products for shipment in manner to prevent damage; for equipment, package to avoid loss of factory calibration.
- B. If special precautions are required, attach instructions prominently and legibly on outside of packaging.
- C. Coordinate schedule of product delivery to designated prepared areas in order to minimize site storage time and potential damage to stored materials.
- D. Transport and handle products in accordance with manufacturer's instructions.
- E. Transport materials in covered trucks to prevent contamination of product and littering of surrounding areas.
- F. Promptly inspect shipments to ensure that products comply with requirements, quantities are correct, and products are undamaged.
- G. Provide equipment and personnel to handle products by methods to prevent soiling, disfigurement, or damage, and to minimize handling.
- H. Arrange for the return of packing materials, such as wood pallets, where economically feasible.

3.04 STORAGE AND PROTECTION

- A. Designate receiving/storage areas for incoming products so that they are delivered according to installation schedule and placed convenient to work area in order to minimize waste due to excessive materials handling and misapplication.
- B. Store and protect products in accordance with manufacturers' instructions.
- C. Store with seals and labels intact and legible.
- D. Store sensitive products in weather tight, climate controlled, enclosures in an environment favorable to product.
- E. For exterior storage of fabricated products, place on sloped supports above ground.
- F. Provide bonded off-site storage and protection when site does not permit on-site storage or protection.
- G. Protect products from damage or deterioration due to construction operations, weather, precipitation, humidity, temperature, sunlight and ultraviolet light, dirt, dust, and other contaminants.
- H. Comply with manufacturer's warranty conditions, if any.
- I. Cover products subject to deterioration with impervious sheet covering. Provide ventilation to prevent condensation and degradation of products.

- J. Prevent contact with material that may cause corrosion, discoloration, or staining.
- K. Provide equipment and personnel to store products by methods to prevent soiling, disfigurement, or damage.
- L. Arrange storage of products to permit access for inspection. Periodically inspect to verify products are undamaged and are maintained in acceptable condition.

END OF SECTION

SECTION 01 60 00
PRODUCT REQUIREMENTS

PART 1 GENERAL

1.01 SECTION INCLUDES

- A. Re-use of existing products.
- B. Transportation, handling, storage and protection.
- C. Product option requirements.
- D. Substitution limitations and procedures.
- E. Procedures for Owner-supplied products.
- F. Maintenance materials, including extra materials, spare parts, tools, and software.

1.02 RELATED REQUIREMENTS

- A. Section 01 40 00 - Quality Requirements: Product quality monitoring.
- B. Section 01 61 16 - Volatile Organic Compound (VOC) Content Restrictions: Requirements for VOC-restricted product categories.

1.03 SUBMITTALS

- A. Proposed Products List: Submit list of major products proposed for use, with name of manufacturer, trade name, and model number of each product.
 - 1. Submit within 15 days after date of Agreement.
 - 2. For products specified only by reference standards, list applicable reference standards.
- B. Product Data Submittals: Submit manufacturer's standard published data. Mark each copy to identify applicable products, models, options, and other data. Supplement manufacturers' standard data to provide information specific to this Project.
- C. Shop Drawing Submittals: Prepared specifically for this Project; indicate utility and electrical characteristics, utility connection requirements, and location of utility outlets for service for functional equipment and appliances.
- D. Sample Submittals: Illustrate functional and aesthetic characteristics of the product, with integral parts and attachment devices. Coordinate sample submittals for interfacing work.
 - 1. For selection from standard finishes, submit samples of the full range of the manufacturer's standard colors, textures, and patterns.

PART 2 PRODUCTS

2.01 EXISTING PRODUCTS

- A. Do not use materials and equipment removed from existing premises unless specifically required or permitted by the Contract Documents.
- B. Unforeseen historic items encountered remain the property of the Owner; notify Owner promptly upon discovery; protect, remove, handle, and store as directed by Owner.
- C. Existing materials and equipment indicated to be removed, but not to be re-used, relocated, reinstalled, delivered to the Owner, or otherwise indicated as to remain the property of the Owner, become the property of the Contractor; remove from site.

2.02 NEW PRODUCTS

- A. Provide new products unless specifically required or permitted by the Contract Documents.
- B. DO NOT USE products having any of the following characteristics:
 - 1. Made outside the United States, its territories, Canada, or Mexico.
 - 2. Made using or containing CFC's or HCFC's.
 - 3. Made of wood from newly cut old growth timber.
 - 4. Containing lead, cadmium, asbestos.

- C. Where all other criteria are met, Contractor shall give preference to products that:
 1. If used on interior, have lower emissions, as defined in Section 01 61 16.
 2. If wet-applied, have lower VOC content, as defined in Section 01 61 16.
 3. Are extracted, harvested, and/or manufactured closer to the location of the project.
 4. Have longer documented life span under normal use.
 5. Result in less construction waste.
 6. Are made of vegetable materials that are rapidly renewable.
 7. Are made of recycled materials.
 8. Have a published GreenScreen Chemical Hazard Analysis.

2.03 PRODUCT OPTIONS

- A. Products Specified by Reference Standards or by Description Only: Use any product meeting those standards or description.
- B. Products Specified by Naming One or More Manufacturers: Use a product of one of the manufacturers named and meeting specifications, no options or substitutions allowed.
- C. Products Specified by Naming One or More Manufacturers with a Provision for Substitutions: Submit a request for substitution for any manufacturer not named.

2.04 MAINTENANCE MATERIALS

- A. Furnish extra materials, spare parts, tools, and software of types and in quantities specified in individual specification sections.
- B. Deliver to Project site; obtain receipt prior to final payment.

PART 3 EXECUTION

3.01 SUBSTITUTION PROCEDURES

- A. Substitutions will only be considered when a product becomes unavailable through no fault of the Contractor.
- B. Document each request with complete data substantiating compliance of proposed substitution with Contract Documents.
- C. A request for substitution constitutes a representation that the submitter:
 1. Has investigated proposed product and determined that it meets or exceeds the quality level of the specified product.
 2. Agrees to provide the same warranty for the substitution as for the specified product.
 3. Agrees to coordinate installation and make changes to other Work that may be required for the Work to be complete with no additional cost to Owner.
 4. Waives claims for additional costs or time extension that may subsequently become apparent.
 5. Agrees to reimburse Owner and Architect for review or redesign services associated with re-approval by authorities.
- D. Substitutions will not be considered when they are indicated or implied on shop drawing or product data submittals, without separate written request, or when acceptance will require revision to the Contract Documents.
- E. Substitution Submittal Procedure (for use when a product becomes unavailable through no fault of the Contractor):
 1. Obtain and use Construction Specifications Institute (CSI) Form 13.1A when submitting a substitution request.
 2. Submit three copies of request for substitution for consideration. Limit each request to one proposed substitution. A single electronic copy is acceptable in lieu of the three paper copies when physical samples are not required.
 3. Submit shop drawings, product data, and certified test results attesting to the proposed product equivalence. Burden of proof is on proposer.
 4. Substitutions will not be considered if the substitution submittal procedure is not followed.

5. Architect will notify Contractor in writing of decision to accept or reject request.

3.02 OWNER-SUPPLIED PRODUCTS

- A. Owner's Responsibilities:
 1. Arrange for and deliver Owner reviewed shop drawings, product data, and samples, to Contractor.
 2. Arrange and pay for product delivery to site.
 3. On delivery, inspect products jointly with Contractor.
 4. Submit claims for transportation damage and replace damaged, defective, or deficient items.
 5. Arrange for manufacturers' warranties, inspections, and service.
- B. Contractor's Responsibilities:
 1. Review Owner reviewed shop drawings, product data, and samples.
 2. Receive and unload products at site; inspect for completeness or damage jointly with Owner.
 3. Handle, store, install and finish products.
 4. Repair or replace items damaged after receipt.

3.03 TRANSPORTATION AND HANDLING

- A. Package products for shipment in manner to prevent damage; for equipment, package to avoid loss of factory calibration.
- B. If special precautions are required, attach instructions prominently and legibly on outside of packaging.
- C. Coordinate schedule of product delivery to designated prepared areas in order to minimize site storage time and potential damage to stored materials.
- D. Transport and handle products in accordance with manufacturer's instructions.
- E. Transport materials in covered trucks to prevent contamination of product and littering of surrounding areas.
- F. Promptly inspect shipments to ensure that products comply with requirements, quantities are correct, and products are undamaged.
- G. Provide equipment and personnel to handle products by methods to prevent soiling, disfigurement, or damage, and to minimize handling.
- H. Arrange for the return of packing materials, such as wood pallets, where economically feasible.

3.04 STORAGE AND PROTECTION

- A. Designate receiving/storage areas for incoming products so that they are delivered according to installation schedule and placed convenient to work area in order to minimize waste due to excessive materials handling and misapplication.
- B. Store and protect products in accordance with manufacturers' instructions.
- C. Store with seals and labels intact and legible.
- D. Store sensitive products in weather tight, climate controlled, enclosures in an environment favorable to product.
- E. For exterior storage of fabricated products, place on sloped supports above ground.
- F. Provide bonded off-site storage and protection when site does not permit on-site storage or protection.
- G. Protect products from damage or deterioration due to construction operations, weather, precipitation, humidity, temperature, sunlight and ultraviolet light, dirt, dust, and other contaminants.
- H. Comply with manufacturer's warranty conditions, if any.
- I. Cover products subject to deterioration with impervious sheet covering. Provide ventilation to prevent condensation and degradation of products.

- J. Prevent contact with material that may cause corrosion, discoloration, or staining.
- K. Provide equipment and personnel to store products by methods to prevent soiling, disfigurement, or damage.
- L. Arrange storage of products to permit access for inspection. Periodically inspect to verify products are undamaged and are maintained in acceptable condition.

END OF SECTION

SECTION 01 77 00 - PROJECT CLOSE-OUT PROCEDURES**PART 1 - GENERAL****1.1. RELATED DOCUMENTS**

- 1.1.1. Provisions established within the Uniform General and Supplementary General Conditions for University of Texas System Building Construction Contracts (UGC), all Sections of Division 1 - General Requirements, other applicable Sections of all Divisions of Specifications, and the Drawings are collectively applicable to this Section. In the event of conflict between specific requirements of the various documents, the more restrictive, the more extensive (i.e.. more expensive) requirement shall govern.

1.2. SECTION OVERVIEW

- 1.2.1. General Description of Closeout Requirements
- 1.2.2. Requirements for Substantial Completion
- 1.2.3. Provisions for Release of Retainage
- 1.2.4. Requirements for Final Acceptance
- 1.2.5. Required Project Record Documents
- 1.2.6. Project Cleaning

1.3. GENERAL DESCRIPTION OF CLOSEOUT REQUIREMENTS

- 1.3.1. DEFINITION: Project Closeout is hereby defined to include requirements near the end of the Contract Time, in preparation for substantial completion acceptance, occupancy by Owner, release of retainage, final acceptance, final payment, and similar actions evidencing completion of the work. Specific additional requirements for individual units of work are specified in Sections of Divisions 2 - 33.
- 1.3.2. TIME of closeout is directly related to completion and acceptance, and therefore may be either a single time period for the entire project, or a series of time periods for individual portions or phases of the project that have been certified as substantially complete at different dates.
- 1.3.3. This Section is based on completion and acceptance of the entire project during a single time period.
 - 1.3.3.1. If the project is to be accepted in phases, whether by originally specified project scope or by subsequent agreement between the parties, then Project Closeout requirements shall pertain to each separately accepted portion or phase of the project; unless by written notice the Owner allows for these requirements to be done singularly upon anticipated acceptance of the final phase.

1.3.4. RECORD DOCUMENTS for Project Closeout include, but are not necessarily limited to the following drafts, which are required at substantial completion:

1.3.4.1. As-Built Record Drawings

1.3.4.2. As-Built Record Specifications

1.3.4.3. Operating & Maintenance Manuals

1.3.4.4. Record Approved Submittals and Samples

1.3.4.5. Certification of No Asbestos or Lead Products Incorporated in Project

1.3.4.6. Completed Punch Lists

1.3.5. REQUIRED DOCUMENTS for final payment to be released include final versions of all of the above and the following:

1.3.5.1. Final Release of Claims & Liens

1.3.5.2. Affidavit of payment of Debt and Claims

1.3.5.3. Consent(s) of Surety

1.3.5.4. Completed SWPPP documents and Notice Of Termination

1.3.5.5. Final Historically Underutilized Business Plan

1.3.5.6. Completed Commissioning and Closeout Manual

1.4. REQUIREMENTS FOR SUBSTANTIAL COMPLETION

1.4.1. Prior to requesting Architect and Owner to schedule a Substantial Completion, or Pre-Final, inspection (for either the entire work or portions thereof as agreed to by the parties to the contract); complete the following and list known exceptions in request.

1.4.1.1. In progress payment request coincident with period of time anticipated for substantial completion, Contractor's payment request should reflect a minimum of 95% completion for all applicable work.

1.4.1.2. Submit to Architect and Owner a complete copy of the Contractor's most current punch list covering the portion(s) of the Project claimed as substantially complete.

1.4.1.2.1. Such punch list shall indicate dates of Contractor re-checks and schedule for completion of work items remaining.

1.4.1.2.2. All items remaining outstanding on the Contractor's punch list shall include a projected date of completion and/or correction with an explanation of why such is not presently completed.

- 1.4.1.3. Submit to Architect for review the full set of as-built marked-up record drawings and marked-up record specifications as described later in this Section.
- 1.4.1.4. Submit to Architect for review the preliminary copies of Owner's Operating and Maintenance (O&M) Manuals as described later in this Section.
- 1.4.1.5. Provide access to Contractor's copy of the Commissioning and Closeout Manual for review by Owner and Architect. The Manual shall be up to date before the Substantial Completion inspection can be requested.
- 1.4.1.6. Submit certification statement that no asbestos or lead containing materials have been used or incorporated into the project.
- 1.4.1.7. Obtain and submit releases enabling Owner's full and unrestricted use of the work and access to services and utilities, including (where applicable) operating certificates, and similar releases.
- 1.4.1.8. Deliver tools, spare parts, extra stocks of materials, and similar physical items to Owner.
- 1.4.2. If Owner intends to occupy Project upon Substantial Completion Acceptance, Contractor shall make provisions for final changeover of locks with the Owner's personnel. Upon written directive from Owner, this task may be waived until final acceptance for the convenience of the Contractor in completing punch list activity.
- 1.4.3. Complete instructions of Owner's personnel for all systems and equipment serving the areas claimed as substantially complete, for which Owner Training was not completed in association with system demonstrations and inspections. Refer also to Section 01 91 00 - Project Commissioning.
- 1.4.4. Complete initial clean up requirements as described later in this Section for the entire portion of the Project claimed as substantially complete. Touch up and otherwise repair and restore marred exposed finishes.
- 1.4.5. **SUBSTANTIAL COMPLETION INSPECTION PROCEDURE**
 - 1.4.5.1. Refer to UGC and Section 01 45 00 - Project Quality Control
 - 1.4.5.1.1. The Contractor shall ensure the work is ready for inspection and/or reinspection. If the work is found not to be as stated in the Contractor's punchlist or the items have not been substantially corrected/completed; the inspection will be terminated all costs for the Owner and A/E team for scheduling and attendance at the terminated inspection(s) shall be the responsibility of the Contractor.

1.5. PROVISIONS FOR RELEASE OF RETAINAGE

- 1.5.1. Refer to UGC

- 1.5.2. Release of any retainage, or reduction in amount of retainage withheld, is strictly at the discretion of the Owner, regardless of Contractor compliance with requirements. All of the requirements noted for Substantial Completion Acceptance must be completed prior to application for final release of contract retainage. In addition, meet the following requirements:
 - 1.5.2.1. Submit affidavits of final release of claim and lien from each subcontractor and supplier who provided materials and/or labor to the Project.
 - 1.5.2.2. Submit affidavit that all bills for the Project have been paid, or will be paid within thirty (30) days of Contractor receipt of payment.
 - 1.5.2.3. Submit Consent of Surety to Release of Retainage.
- 1.6. REQUIREMENTS FOR FINAL ACCEPTANCE
 - 1.6.1. Prior to requesting Architect and Owner to schedule Final Inspection for the Project, complete the following:
 - 1.6.1.1. Prepare draft payment request showing 100% completion for each line item on the Schedule of Values. Submit with this draft all final releases and supporting documentation not previously submitted and accepted. Include Certificates of Insurance where applicable. Note that Final Payment, including final release of retainage, will not be issued until all work (including punch list items) has been completed, all requirements met, a project closeout audit performed (if deemed necessary) and a Final Change Order has been processed if required to resolve final cost or closeout audit issues, including deletion of any remaining contract allowances.
 - 1.6.1.2. Submit copy of Architect/Engineer's pre-final, or substantial completion, punch list, which includes evidence that each item has been completed or otherwise resolved.
 - 1.6.1.3. Submit final meter readings for utilities, and similar data as of time of substantial completion or when Owner took possession of and responsibility for corresponding elements of the work.
 - 1.6.1.4. Submit final record as-built drawings and specifications, copies of all approved submittals, and operating & maintenance manuals as described later in this Section. This includes specific warranties, maintenance agreements, product certifications and similar documents. Record closeout documentation must be acceptable to Architect and Owner prior to issuance of final payment.
 - 1.6.1.5. Transmit completed Commissioning and Closeout Manual to the Owner. This manual shall be complete, acknowledging receipt of all attic stock, spare parts, training/demonstration, test reports and any other requirements of the contract documents.
 - 1.6.1.6. Complete final cleaning requirements, including touch-up of marred surfaces.

1.6.1.7. Submit final payment request, including the following documentation:

- 1.6.1.7.1. Consent of Surety
- 1.6.1.7.2. Release of Liens and Claims
- 1.6.1.7.3. Affidavit of payment of Debts and Claims
- 1.6.1.7.4. Final Historically Underutilized Business Plan
- 1.6.1.7.5. Completed and signed Notice Of Termination

1.6.1.8. Revise and submit evidence of final and continuing insurance coverage complying with applicable insurance requirements.

1.6.2. FINAL ACCEPTANCE INSPECTION PROCEDURE

1.6.2.1. Upon compliance with all above noted requirements, and following completion of the work required in the substantial completion punch list, provide written notice to the Architect and Owner that the project is ready for Final Inspection. Refer to UGC for additional requirements.

1.6.2.2. All Owner and Architect costs for travel and man-hours for additional inspections at either Substantial Completion or Final Acceptance which are required either by failure of the Contractor to complete the noted punch list items, or by erroneous notices that the work is ready for such inspections, will be the responsibility of the Contractor. Such costs will be deleted from the contract amount in Change Order.

1.7. AS-BUILT RECORD DRAWINGS

1.7.1.1. Do not use record documents for construction purposes; protect from deterioration and loss in a secure location; provide access to record documents for Owner and/or Architect's reference or review during normal working hours.

1.7.1.2. In general terms; the Contractor is to furnish one set of 4 mil Mylar prints made from the Architect's contract drawings, or subsequent updates thereof, annotated as noted below with actual as-built conditions, two sets of prints made from the mylars, and the original marked-up prints.

1.7.1.2.1. As-built information is to be professionally drafted on first-generation contract prints from which the mylars are to be made.

1.7.1.2.2. As-builts are required to show all changes in the work relative to the original contract documents; and show additional information of

value to Owner's records, but not indicated in original contract documents.

- 1.7.1.3. Record as-builts are to include marked-up copies of contract drawings and specifications, including newly-prepared drawings if any such are applicable or necessary to achieve the intended result, and shop drawings to include all changed conditions issued through addenda and/or change orders.
 - 1.7.1.3.1. Include marked up product data submittals, field records for variable and concealed conditions such as excavations and foundations, and further; miscellaneous record information on work, which is otherwise recorded only schematically or not at all.
- 1.7.1.4. Certain individual sections of Divisions 2 through 33 indicate specific requirements, which may clarify requirements of this section. Where a conflict may be perceived to exist, the more restrictive (i.e., more expensive) requirement will prevail. There is no intent, however, to require more sets of as-builts than is indicated herein.
- 1.7.1.5. The Contractor shall bear all costs associated with obtaining the Architect's original contract documents, or subsequent updated plots thereof, drafting of as-built information, reproduction, including mylar drawings, or other related work.
 - 1.7.1.5.1. All "as built" changes shall be of good drafting quality, performed by a person skilled in drafting and knowledgeable of the conventions of the trades involved.
 - 1.7.1.5.2. The Contractor may utilize his staff or seek outside assistance, including the Project Architect, for this drafting work so long as the requirements pertaining to quality, format, and content are met.
- 1.7.1.6. **MAINTENANCE OF AS-BUILT DRAWINGS DURING CONSTRUCTION**
 - 1.7.1.6.1. During progress of the work, maintain a printed set of contract drawings along with specifications and shop drawings in the construction office. Update these drawings weekly, at a minimum, with markup of actual installations, which vary from the work as originally shown.
 - 1.7.1.6.1.1. Mark whatever drawing is most capable of showing actual physical condition, fully and accurately, and reference all other appearances of this work to the sheet, which was updated. Include cross-reference to the official change number on the updated sheet and all additional sheets where the work is shown.

- 1.7.1.6.1.2. Mark with erasable colored pencil, using separate colors where feasible to distinguish between changes for different categories of work at same general location.
- 1.7.1.6.1.3. Mark up important additional information, which was either shown schematically or omitted from original drawings. Give particular attention to information on work concealed, which would be difficult to identify or measure and record at a later date.
- 1.7.1.6.1.4. Note alternative numbers, change order numbers and similar identification for any change.
- 1.7.1.6.1.5. Require each person preparing markup to initial and date markup and indicate name of firm.
- 1.7.1.6.2. The Contractor shall maintain and have available for review in conjunction with the regular project meetings, a current set of the as-built drawings and specifications marked with "as constructed" information. Availability for review, and acceptability, of both the format and the content is a prerequisite condition for certification of monthly pay requests by the Owner and Architect.

1.7.2. SUPPLEMENTAL DRAWINGS

- 1.7.2.1. Where marked-up shop drawings are intended for inclusion in the record set, mark cross-reference on contract drawings at corresponding location. Use of shop drawings as supplements to the record as-builts is encouraged for all items which require the larger scale employed on the shop drawings in order to show the work in sufficient detail to be of future use to the Owner.
 - 1.7.2.1.1. Use of such shop drawings is particularly applicable to ductwork and electrical shop drawing layouts. Use of shop drawing supplements is acceptable so long as the following conditions are met:
 - 1.7.2.1.1.1. Regardless of overall size of the original shop drawings, such will be reproduced photographically onto mylar sheets of the same size with equivalent borders and titles as the contract drawings and other record as-built drawings. Include project name and number as well as the applicable submittal number.
 - 1.7.2.1.1.2. The applicable supplemental sheet shall be placed in the set directly behind the contract drawing, which it supplements, with appropriate reference notes on both the applicable contract drawing and all other affected drawings.

- 1.7.2.1.1.3. The supplemental document shall be identified as a "Supplementary Record As-Built Drawing" and shall be numbered with an extension to the contract drawing it supplements in a manner acceptable to the Owner.

1.7.3. PREPARATION OF FINAL AS BUILT DRAWINGS

- 1.7.3.1. This Section requires that a copy of the marked-up as-builts be submitted to the Architect for review prior to requesting substantial completion inspections.

- 1.7.3.1.1. Following the Architect's review of the marked-up prints, and upon authorization by the Architect based on their belief that the marked-up information is accurate and complete, the Contractor shall proceed with preparation of a full set of professionally drafted record drawings.

- 1.7.3.2. All record as-built drawings and supplemental shop drawing sheets must be reproduced on 4-mil thick mylar film. This includes the entire set of contract drawings, whether or not individual sheets are affected by as-built data. Mylars shall be made from the first-generation prints of the contract drawings; mylars or sepias made from marked up prints will not be accepted under any circumstances.

- 1.7.3.3. All drawings shall bear the official project name and number. Further, each drawing, including supplemental drawings, shall also bear a stamp to the effect of "Record As-Built" along with the Contractor's certification that such is an accurate reflection of actual as-built conditions. Each certification shall be signed and dated and shall be acceptable to the Owner.

- 1.7.3.3.1. All drawings shall be the same size as original contract documents.

- 1.7.3.3.2. All "as built" notes and drafting on mylars should be made with ink for use on mylars (no pencil lead or colored pencil).

- 1.7.3.3.3. The marked-up prints shall be turned over to the Architect along with the final mylar documents for review and acceptance. Once such final mylar documents are acceptable to the Architect as complying with this section and other contract requirements. They will transmit final mylars to the Owner along with the marked-up prints and all other close-out documentation

- 1.7.3.3.4. All drawings issued as addenda, clarifications and/or change orders shall be incorporated into the record as-built drawing set. Such shall be fully shown on the applicable contract drawing. If supplemental sheets are used, follow the requirements outlined above for supplemental shop drawing sheets.

1.7.4. AS-BUILT RECORD SPECIFICATIONS

- 1.7.4.1. During progress of the work, maintain and update one record copy of specifications at the jobsite, including addenda, change orders and similar modifications issued in printed form during construction, to indicate all significant variations in actual work in comparison with text of specifications as originally issued.
 - 1.7.4.1.1. Give particular attention to substitutions, selection of options, and similar information on work where the exact products used are not clearly identified or readily discernable in the original specifications. Note related record drawing information and product data, where applicable.
 - 1.7.4.1.2. It is not necessary to re-type an entire section if modified, but it is mandatory that all changes to specified materials, installation, warranty, etc. be clearly and fully marked within the applicable specifications section in a manner acceptable to the Architect and the Owner. Such should be reviewed and a documentation procedure established early in the construction period.
- 1.7.4.2. In association with request for substantial completion inspection, submit the marked-up copy of the Project Specifications to the Architect for review.
- 1.7.4.3. Once the marked-up Project Specifications are found acceptable by the Architect, and upon his authorization, based on his belief that the marked-up information is accurate and complete; proceed with preparation of a Record Set Project Specifications.
 - 1.7.4.3.1. Neatly transcribe and post all as-built mark-up information to a "clean" copy of the Project Specifications, insuring that similar types of information is annotated in like fashion throughout the Specifications.
- 1.7.4.4. Once completed, submit both the mark-up site copy of the Project Specifications and the newly prepared Record Project Specifications to the Architect for review and, if acceptable, for subsequent transmittal to the Owner.

1.7.5. OPERATING AND MAINTENANCE MANUALS

- 1.7.5.1. In general terms, the Contractor is to organize maintenance-and-operating manual information into suitable sets of manageable size, and bind into individual binders properly tabbed and indexed.
 - 1.7.5.1.1. Such shall include emergency instructions, spare parts listings, warranties, wiring diagrams, inspection procedures, shop drawings, product data, and similar applicable information.

- 1.7.5.1.2. Such shall be bound in heavy-duty, 3-ring vinyl-covered binders including pocket folders for folded sheet information. Mark binder identification on both front and spine of each binder.
- 1.7.5.1.3. Two complete copies of each bound O&M Manual are required.
- 1.7.5.2. The requirements of this Section are separate, distinct and in addition to product submittal requirements that may be established by other Sections of the Specifications. Owner's manuals, manufacturer's printed instructions, parts lists, and other submittals required by other Sections of the Specifications may be included in the O&M Manuals provided that they are approved and are formatted in a manner consistent with the requirements of this Section.
- 1.7.5.2.1. Test data and Commissioning data included in the O&M Manuals need not be duplicated in the Commissioning and Closeout Manual. Test data not pertaining to a particular device or piece of equipment (such as domestic water pipe pressure test reports) shall be inserted in the C&C Manual.
- 1.7.5.3. Equipment is defined as any mechanism, mechanical, electrical or electronic device, or any combination thereof, which is made up of two or more working parts to perform a particular function.
- 1.7.5.4. When an item of equipment is a packaged unit furnished by one manufacturer and the package as furnished contains proprietary items of equipment obtained from other sources; copies of equipment data as required herein shall be furnished for each item of such equipment as if it had been separately furnished.
- 1.7.5.5. For general guidance only, the following are examples of equipment, material, and systems for which operating and maintenance data is required:
- | | |
|--------------------------|------------------------|
| Pipe & Fittings | Air Handling Units |
| Gate Valve | Temperature Controls |
| Elevators | Pumps and Controllers |
| Electrical Switchgear | Irrigation System |
| Light Fixtures | Fire Sprinkler |
| Transformers | Security Systems |
| Electric Panel | Wall Light Switches |
| Circuit Breakers | Motors & Devices |
| Metal Fabrications | Telephone Systems |
| Pressure Gauges | Fume Hoods |
| A/C Diffusers | Fire Alarm System |
| Sterilizers | Compressors |
| Laboratory Casework | Overhead Coiling Doors |
| Finish Hardware | Access Flooring |
| Automatic Door Operators | Finish Materials |

- 1.7.5.6. All the applicable data for any one item of equipment or material or system shall be bound together as a package, within a Manual containing like equipment, materials, or systems, as indicated by the appropriate specification division. Each package of data shall be numbered according to the Specification Section governing the particular system.
- 1.7.5.7. All data furnished in accordance with this Section shall be submitted on bindable 8-1/2" x 11" sheets or on sheets that are bindable and foldable multiples of 8-1/2" x 11". The bindable edge shall be the left 11" edge.
- 1.7.5.8. Waivers to the size requirement may be requested in specific instances upon application in writing to the Architect and Owner with justification for substitution in size.
- 1.7.5.9. Material and equipment data required by this Section is intended to include all data necessary for the proper installation, removal, normal operation, emergency operation, startup, shutdown, maintenance, cleaning, adjustment, calibration, lubrication, assembly, disassembly, repair, inspection, trouble shooting and service of the equipment or materials.
- 1.7.5.10. The UGC requires that a preliminary copy of all operating and maintenance manuals, in addition to as-built documents, be furnished prior to the Substantial Completion inspection. The Contractor is to accumulate and package the documentation, and submit it to the Architect for review.
- 1.7.5.11. The Contractor's submission of a preliminary copy of all O&M Manuals to the Architect for review is a precondition for scheduling of a Substantial Completion Inspection. The Contractor's final submission of these Manuals in an acceptable format (based on review of preliminary copies by the Architect) is a precondition for scheduling of a Final Acceptance Inspection, release of remaining contract retainage, or application for Final Payment.
- 1.7.5.12. Equipment Data to be Included in O&M Manuals
 - 1.7.5.12.1. Description of Equipment shall be prepared upon 8-1/2" x 11" forms. Include one such form for each item of equipment. Refer also to the equipment list requirements of Sections 01 91 00 - Project Commissioning, 23 00 00 - General Mechanical and 26 00 00 - General Electrical. The equipment information to be included in the O&M Manuals is as follows:
 - 1.7.5.12.1.1. Complete description of item: Such should list basic descriptive terminology first, followed by modifying words to include model, size and weight, flow rate, amperage, voltage, material, etc., as applicable, plan designation, if any, and package serial number
 - 1.7.5.12.1.2. Part Number: Manufacturer's and supplier's part number.

- 1.7.5.12.1.3. Quantity: Total quantity of this equipment item installed under this Contract.
- 1.7.5.12.1.4. Specification Paragraph Reference: State the specification section and paragraph under which the item of equipment was procured, and page number.
- 1.7.5.12.1.5. Source: Manufacturer's name and address and supplier's name and address.
- 1.7.5.12.1.6. Serial Number: Complete manufacturer's serial number(s) or other identity symbol(s) as applicable.
- 1.7.5.12.1.7. Location: State the name of the system and/or sub-system in which each like item of equipment is installed and state the physical location of each like item of equipment by identifying the columnar grid intersections, as shown on the plans, near which the item is located and also state the room or space title as applicable.
- 1.7.5.12.2. Parts Lists which clearly identifies every part in the item of equipment with the proper manufacturer's name, part nomenclature and number, local source, and list price.
- 1.7.5.12.3. Recommended Spare Parts. Furnish a list of recommended spare parts for each equipment item that will be needed to support that item of equipment for a 12-month period. The quantities of spare parts recommended shall be based upon the quantity of like equipment items installed under the Contract. The recommended spare parts list for each equipment item shall be prepared upon 8-1/2" x 11" forms which contain the following information for each part in columns:
 - 1.7.5.12.3.1. Part Description: Complete descriptive nomenclature plus manufacturer's complete model and part number, and list price cost for each part.
 - 1.7.5.12.3.2. Quantity Per Assembly: Quantity of listed part that occurs in the item of equipment.
 - 1.7.5.12.3.3. Quantity of Equipment Items: Quantity of like equipment items installed under this Contract.
 - 1.7.5.12.3.4. Shelf Life: Storage life of part, in months, if the part has limited life.
 - 1.7.5.12.3.5. Recommended Quantity: Quantity of part recommended to support the installed quantity of equipment in which the part appears for a period of 12 months.

- 1.7.5.12.3.6. Source for part: Name, address, and phone number of the nearest supplier for the part.
- 1.7.5.12.4. Contractor's Purchase Order: Copy of Contractor's purchase order for equipment. The copy furnished need only show quantity ordered, part number, equipment description and name and address of vendor who supplied the item
- 1.7.5.12.5. Normal Operating Instructions: Normal operating instructions shall provide sufficient detailed information to permit a journeyman mechanic to adjust, startup, operate and shut down the equipment. Special startup precautions must be noted as well as other action items required before the equipment is put into service.
- 1.7.5.12.6. Emergency Operating Procedures: A detailed description of the sequence of action to be taken in the event of a malfunction of the unit, either to permit a short period of continued operation or emergency shutdown to prevent further damage to the unit and to the system in which it is installed.
- 1.7.5.12.7. Preventive Maintenance: Detailed information to cover routine and special inspection requirements, including field adjustments, inspections for wear, adjustment changes, packing wear, lubrication points, frequency and specific lubrication type required, cleaning of the unit and type solvent to use, and such other measures as are applicable to preventive maintenance program.
- 1.7.5.12.8. Calibration: Detailed data on what to calibrate, how to calibrate, when to calibrate and procedures to enable checking the equipment for reliability or indications as well as data for test equipment, special tools and the location of test points.
- 1.7.5.12.9. Scale and Corrosion Control: Detailed information covering the prevention of and removal of scale and corrosion.
- 1.7.5.12.10. Troubleshooting Procedures: Detailed information and procedures for detecting and isolating malfunctions and detailed information concerning probable causes and applicable remedies.
- 1.7.5.12.11. Removal and Installation Instructions: Detailed information concerning the logical sequence of steps required to remove and install the item including instructions for the use of special tools and equipment.
- 1.7.5.12.12. Disassembly and Assembly Instructions: Detailed illustrations and text to show the logical procedure and provide the

instructions necessary to disassemble and assemble the unit properly. The text shall include all checks and special precautions as well as the use of special tools and equipment required to perform the assembly or disassembly.

- 1.7.5.12.13. Repair Instructions: Detailed repair procedures to bring the equipment up to the required operating standard including instruction for examining equipment and parts for needed repairs and adjustments, and tests or inspections required to determine whether old parts may be reused or must be replaced.
- 1.7.5.12.14. System Drawings: Detailed drawings, where applicable, that clearly show wiring diagrams, control diagrams, system schematics, pneumatic and fluid flow diagrams, etc., which pertain to the unit function. Drawings are required to show modifications to another manufacturer's standard unit which is incorporated into the assembly or package unit
 - 1.7.5.12.14.1. System diagrams shall be provided on multiples of 8-1/2" x 11" format, folded to fit within the Manual. The outer (exposed) face of the folded drawing shall include identification of the system and the specification section that governs its installation and operation.
 - 1.7.5.12.14.2. The requirements of this paragraph are separate, distinct, and in addition to similar requirements that may be established by other Sections. Where such system diagrams are required for submittal by other specification sections, the same diagrams will be acceptable for inclusion herein, so long as the diagrams used were approved during the submittal phase and they are reproduced for clarity and to fit the size format of the O&M Manual.
 - 1.7.5.12.14.3. The Contractor shall provide diagrammatic drawings for each installed system, which shall show the placement of the system in relation to the building, and the physical location of each item or equipment installed within the system. Each installed item of equipment shown on the drawing will be identified by the equipment item model and/or serial/part number.
 - 1.7.5.12.14.4. System drawings may, for purpose of clarity, be prepared upon a major subsystem basis.
 - 1.7.5.12.14.5. The drawings may be prepared upon several drawings having referenced match lines.

- 1.7.5.12.15. Special Tools and Test Equipment: Furnish a detailed list of the special tools and test equipment needed to perform repair and maintenance for each equipment item. The list shall contain the special tool and test equipment part number, size, quantity, price, manufacturer's name and address, and local supplier's name and address.
- 1.7.5.12.16. Warranties & Guarantees: Bind within the tabbed section for each system, equipment item, or material, an executed copy of the specified warranty/guarantee covering that particular system, equipment item, or material.
- 1.7.5.12.16.1. This is to include both the manufacturer's warranty as specified and the installing contractor's guarantee for workmanship and system operation.
- 1.7.5.12.16.2. This copy of the particular warranty/guarantee is in addition to original signature copies of all project warranties/guarantees bound together separately. This binder shall be transmitted to the Owner when complete.
- 1.7.5.12.16.3. Provide in a separate tabbed section of the O&M Manual a grouping of all project warranties and guarantees as required by various specification sections and other conditions of the Contract. This is to include all specific warranties on manufactured items and installed systems as noted above, in addition to General Contractor's project warranty and applicable guarantees from all subcontractors and suppliers covering defects in workmanship or manufacture.
- 1.7.5.12.16.4. As clarification, it is intended that the Owner be provided with a separate binder containing all original project warranties and guarantees. Also provide a copy of the appropriate warranty in the same section as the equipment (or system) data furnished in individual tabbed sections of the O&M Manuals for convenient reference.
- 1.7.5.12.17. Training of Owner Personnel: Documentation of training of Owner's Personnel regarding operation of particular systems shall be included within the tabbed section for that particular system. Such documentation shall include identification of parties receiving training and date(s) of such training.

1.7.6. MISCELLANEOUS RECORD INFORMATION

- 1.7.6.1. The following shall be bound in like manner to above noted equipment data and system drawings. It is suggested that a separate tabbed section be included in the Commissioning and Closeout Manual for these

Miscellaneous Items. Categories of requirements resulting in miscellaneous work records are recognized to include, but not limited, the following:

- 1.7.6.1.1. Required field records on excavations, foundations, underground construction, wells and similar work.
- 1.7.6.1.2. Accurate survey showing locations and elevations of underground lines, including invert elevations of drainage piping.
- 1.7.6.1.3. Surveys establishing lines and levels of building.
- 1.7.6.1.4. Plant treatment records (wood, soil, etc)
- 1.7.6.1.5. Certifications received in lieu of labels on products and similar record documentation.
- 1.7.6.1.6. Batch mixing and bulk delivery records.
- 1.7.6.1.7. Testing and qualification of tradesmen.
- 1.7.6.1.8. Documented qualification of installation firms.
- 1.7.6.1.9. Load/performance testing.
- 1.7.6.1.10. Final inspection and deficiency corrections.

1.7.7. RECORD PRODUCT SUBMITTALS

- 1.7.7.1. During progress of the work, maintain approved copies of each product data submittal and shop drawing, and mark up significant variations in the actual work in comparison with submitted information. Include both variations in product as delivered to site, and variations from manufacturer's instructions and recommendations for installation.
 - 1.7.7.1.1. A separate binder with one copy off all MSDS sheets for any and all products incorporated into the project shall be maintained during the course of the project. This binder shall be included in the record submittal documents.
- 1.7.7.2. Give particular attention to concealed products and portions of the work that are not clearly identified in the original submittal or cannot otherwise be readily discerned at a later date by direct observation. Cross reference to change orders and markup of record drawings and specifications.
- 1.7.7.3. Upon completion of as-built revisions, submit two complete sets of all approved submittals to Architect for review and subsequent transmittal to Owner. Organize and group files in sturdy file boxes with tabbed dividers for each separate specification division. Include a complete table of contents.

- 1.7.7.4. These record submittal requirements are in addition to inclusion of similar material as supplementary as-built drawings or technical data for the O&M Manuals.

1.7.8. RECORD SAMPLE SUBMITTAL

- 1.7.8.1. Immediately prior to date(s) of substantial completion, arrange for Architect and Owner's representative to meet with Contractor at site to determine which (if any) of the submitted samples or mock-ups maintained by Contractor during progress of the work are to be transmitted to Owner for record purposes.
- 1.7.8.2. Comply with Architect's instructions for packaging, identification marking, and delivery to Owner's designated location at the Project Site or the Physical Plant.
- 1.7.8.3. Dispose of other samples in manner specified for disposal of surplus and waste materials, unless otherwise indicated or directed by Architect.

1.7.9. COMMISSIONING AND CLOSEOUT MANUAL (C&C Manual)

- 1.7.9.1. The Contractor shall incorporate all commissioning and closeout documentation and/or verification not included in the O&M manuals, into a Manual for transmittal to the Owner at the conclusion of the project. This Manual is intended to be a consolidation of documentation/verification for the project Commissioning and Closeout process.

- 1.7.10. Requirements for production of this manual are found in Section 01 91 00 Project Commissioning.

PART 2 - PRODUCTS (NOT USED)

PART 3 - EXECUTION

3.1. PROJECT CLEANING AT SUBSTANTIAL COMPLETION

- 3.1.1. The Contractor is required to maintain the project and site in a clean and orderly condition throughout the course of construction. In addition to continuous project cleaning, the following requirements are related to project closeout.
- 3.1.2. Special cleaning for specific units of work may also be specified in other sections of Project Specifications.
- 3.1.3. Provide an initial cleaning of the work consisting of cleaning each surface or unit of work to normal "clean" condition expected for a first-class building cleaning and maintenance program.
- 3.1.4. Comply with manufacturer's instructions for cleaning of all system components, equipment, and materials incorporated into the Project.

3.1.5. The following "initial" final cleaning is to be accomplished immediately prior to the time the Contractor requests Substantial Completion Inspection:

- 3.1.5.1. Remove labels that are not required as permanent labels.
- 3.1.5.2. Clean exposed hard-surfaced finishes, including glass, metals, stone, concrete, painted surfaces, plastics, tile, wood, special coatings, and similar surfaces, to a dirt-free condition, free of dust, stains, films and similar noticeable distracting substances. Restore reflective surfaces to original condition.
- 3.1.5.3. Remove debris and surface dust from limited-access spaces including plenums, shafts, and similar spaces.
- 3.1.5.4. Clean concrete floors in non-occupied spaces, wet-mop and broom clean.
- 3.1.5.5. Clean fixtures and lamps of all dust and debris.
- 3.1.5.6. Remove crates, cartons and other flammable waste materials or trash from work areas. Building(s) shall be turned over to the Owner free of concealed garbage, trash and rodent infestation. If any of the preceding are revealed, or odors from them occur, they shall be removed by the Contractor at his expense. Restore property to its original condition where no improvements are shown.
- 3.1.5.7. Elevator shafts, electrical closets, pipe and duct shafts, chases, furred spaces, and similar spaces which are generally unfurnished, shall be cleaned and left free from rubbish, loose plaster, mortar drippings, extraneous construction materials, dirt and dust.
- 3.1.5.8. Rubbish shall be lowered by way of chutes, taken down on hoists, or lowered in receptacles. Under no circumstances shall any rubbish or waste be dropped or thrown from one level to another within or outside the building(s).
- 3.1.5.9. Care shall be taken by workmen not to mark, soil or otherwise deface finished surfaces. In the event that finished surfaces become defaced, all costs for cleaning and restoring such surfaces to their originally intended condition shall be the responsibility of the Contractor.

3.2. PROJECT CLEANING AT FINAL ACCEPTANCE

3.2.1. The following "final" cleaning is to be accomplished immediately prior to the time the Contractor requests Final Acceptance Inspection:

- 3.2.1.1. Clean transparent materials, including mirrors and window/door glass, to a polished condition, removing substances that are noticeable as vision-obscuring materials.
- 3.2.1.2. Turn the work over in immaculate condition inside and outside including the premises.

- 3.2.1.3. Clean all work on the premises including walks, drives, curbs, paving, fences, grounds and walls. Slick surfaces shall be left with a clear shine. Cleanup shall include removal of smudges, marks, stains, fingerprints, soil, dirt, paint, dust, lint, labels, discolorations and other foreign materials.
- 3.2.1.4. Clean all finished surfaces on interior and exterior of project (again) including floors, walls, ceilings, windows, glass, doors, fixtures, hardware and equipment. Final wax and polish all natural finish metal on interior or exterior surfaces. Clean and apply finish (including wax) to all floors as recommended by the manufacturer.
- 3.2.1.5. In addition to the cleaning specified above and the more specific cleaning required in various Sections of the Specifications, the building(s) shall be prepared for occupancy by a thorough cleaning throughout, including washing (or cleaning by approved methods) surfaces on which dirt or dust has collected, and by washing glass on both sides. Wash exterior glass using a window-cleaning contractor specializing in such work.
- 3.2.1.6. Remove temporary buildings and structures, fences, scaffolding, surplus materials and rubbish of every kind from the site of the work. Repair these areas to be compatible with the surrounding construction finished condition.

END OF SECTION 01 77 00



The University of Texas
Health Science Center at Houston

REVISION LOG

The following is provided for convenience to the Owner, Architect/Engineer and Contractor to track changes between annual document issuances and is not to be considered by any party to be contractual or 100% complete.

Date	Paragraph Revised
3/1/11	General revisions

SECTION 01 91 00 – GENERAL COMMISSIONING REQUIREMENTS

PART 1 GENERAL

1.1 SUMMARY

- 1.1.1 Commissioning (Cx) is a quality-oriented process of assuring that a facility is constructed and performs as intended in accordance with the contract documents. The process confirms that all building systems (including building envelope) have been installed and exercised throughout their full range of intended operation, and that anticipated failures have been initiated or simulated to verify response and recovery.
- 1.1.2 Commissioning requires cooperation and direct involvement by all parties throughout the construction process. Successful Cx requires not only that all building systems and assemblies comply with contract requirements, but also that installation is achieved early enough in the construction phase to allow full operational check-out, testing, and adjusting of equipment and systems prior to Substantial Completion. Planning adequate time for all Cx activities will require the development and maintenance of a detailed Cx schedule with input from, and the active participation of, all members of the Cx team.
- 1.1.3 In addition to fulfilling scheduling and planning requirements, the Contractor is responsible for verifying and documenting equipment and system installation as well as demonstrating and documenting operational performance of all systems and assemblies. This includes successful demonstration of full systems integration in the facility to the Owner's Designated Representative (ODR). The cost of Cx administration as outlined in this specification shall be shown as a separate line item on the Contractor's schedule of values.
- 1.1.4 The Contractor is solely responsible for all Cx responsibilities contained in the project plans and specifications. The Contractor shall submit to the Owner within 30 days after Notice to Proceed the resume of a qualified individual to act as the Contractor's Commissioning Coordinator (CxC). The CxC shall be a full-time project resource and will be the primary point of contact for all Cx related activities. The proposed individual shall have formal Cx credentials from UW, BCA, AEE, ACG, or ASHRAE, or other Cx credentials can be submitted for evaluation and potential acceptability. The individual proposed to fill the Contractor's CxC role must be approved by the Owner. Fulfilling the Contractor's responsibilities for the CxC, as outlined herein, shall be the individual's primary role for the project. The CxC cannot be the project manager or a project superintendent. The Contractor may elect to outsource the CxC position to a third party firm with the approval of the Owner, and the outsourced individual filling the role of the CxC must be a full-time project resource. Outsourcing the CxC role will be contingent upon Owner review and approval of the proposed individual's qualifications to fill the position.

1.2 DEFINITIONS

- 1.2.1 Commissioning Coordinator (CxC) -- the individual appointed by the Contractor (and approved by the Owner) to act as the Contractor's single point-of-contact for all Cx related activities.
- 1.2.2 Cx Authority (CxA) -- the party having a contract Agreement with the Owner to provide third party Cx services as a consultant to the Owner. In some cases, the CxA will be contracted by the A/E firm.
- 1.2.3 Cx Team Members -- all parties who represent the Owner, A/E, Contractor, Subcontractors, Manufacturers, Vendors, and Suppliers and Consultants associated with the project.
- 1.2.4 Contractor's Cx Record (CCR) -- the compilation of Cx related documentation including but not limited to the Commissioning Plan, the Equipment Matrix, Close-out Documentation Matrix, Cx Schedule, observation reports, inspections, meeting minutes, Cx checklists/testing scripts/procedures, etc.
- 1.2.5 Building Automation System (BAS) – A control system designed to automatically control and monitor building systems.
- 1.2.6 Owner's Project Requirements (OPR) – A formal document developed early in the design process that communicates what the Owner wants accomplished in the project.
- 1.2.7 Basis of Design (BOD) – A formal document developed by the design team early in the design process that communicates how the systems designed will meet the project objectives.
- 1.2.8 UW – University of Wisconsin
- 1.2.9 AEE – The Association of Energy Engineers
- 1.2.10 ACG – AABC Commissioning Group
- 1.2.11 BCA – The Building Commissioning Association
- 1.2.12 ASHRAE – The American Society of Heating, Refrigerating, and Air-conditioning Engineers

1.3 RELATED DOCUMENTS

- 1.3.1 The Uniform General Conditions, applicable requirements of all Divisions of the Contract specifications and all Contract Drawings apply to work of this section. In the event of conflict between specific requirements of the various documents, the more restrictive, the more extensive (i.e., more expensive) requirement shall apply.

1.3.2 Technical specifications throughout all Divisions of the Project Manual, which pertain to operable and non-operable equipment and/or building systems, are directly applicable to this section, and this section is directly applicable to them. Particular attention is directed to:

- 1.3.2.1 Division 1 General Requirements, specifically
 - Section 01 32 16 – Project Planning and Scheduling
 - Section 01 45 00 – Project Quality Control
 - Section 01 77 00 – Project Closeout Procedures
- 1.3.2.2 Divisions 7-14
- 1.3.2.3 Divisions 21-33 sections as appropriate, and Cx-specific sections:
 - Section 21 08 00 – Commissioning of Fire Protection Systems
 - Section 22 08 00 – Commissioning of Plumbing Systems
 - Section 23 08 00 – Commissioning of Mechanical Systems
 - Section 26 08 00 – Commissioning of Electrical Systems

1.4 WORK INCLUDED

1.4.1 SCOPE OF THIS SECTION

- 1.4.1.1 It is of primary concern that all systems installed in the project perform in accordance with the design intent and the OPR. This is particularly critical for systems affecting life safety, building controls, plumbing, HVAC, building envelope, lighting, power delivery systems, security system, article protection system, and access control system.
- 1.4.1.2 This section establishes minimum general and administrative requirements pertaining to Cx progress-tracking tools, documentation of installation, startup and performance testing of equipment, devices, assemblies and building systems. Additional technical and operational requirements for particular systems and components are established in the various technical sections of the specifications. The Contractor is solely responsible for the Cx process. This responsibility shall not be delegated to subcontractors, but by necessity will require the participation of subcontractors.
- 1.4.2 UTHSCH will provide the Contractor with an electronic copy of standard Cx coordination and tracking tools, and document templates for various inspections, outage requests, reports, etc. Cx-related documents, including tracking tools will be delivered to the Owner at Substantial Completion as part of the CCR. The Contractor shall customize the provided tools and templates to meet the specific details of the project. It is the responsibility of the Contractor to develop project-specific documentation forms and tracking tools where they are not provided by UTHSCH.

1.4.3 The Owner's Quality Assurance (QA) testing and inspection program is independent of the Cx program. The Contractor is required to perform all testing (or provide or make available portions of the building for consultant and/or third party testing) as specified in the contract documents in addition to the Cx requirements outlined herein. Coordination of these processes by the Contractor will help minimize any duplication of effort. Unless stipulated elsewhere in the contract documents, QA testing and inspection documentation shall be included in the CCR.

1.5 COMMISSIONING PLAN

1.5.1 The Cx Plan is a detailed description of the entire Cx process. The Cx Plan identifies processes, procedures, roles and responsibilities, and protocols to be administered and managed by the Contractor to satisfy the Cx responsibilities included in the contract documents. The Cx Plan provides a step-by-step outline to assure the Owner's project requirements are met during the construction process. The Contractor is responsible for development, implementation and maintenance of the Cx plan, and associated tools for scheduling and tracking Cx activities. The Owner may choose to engage a CxA to develop a draft construction phase Cx plan. When a draft Cx plan is provided by the Owner's CxA, the Contractor is required to review, submit recommended changes, and update the draft (template) Cx plan with approved changes. The Contractor shall adopt the final approved draft Cx plan as the project's Cx plan. The Cx plan will include, as a minimum, the following Project Cx Team Members:

- 1.5.1.1 Contractor's Cx Coordinator (CxC)
- 1.5.1.2 UT Health Science Center –Houston Facilities, Planning and Engineering (UTHSCH)
- 1.5.1.3 A/E and relevant consultants
- 1.5.1.4 Institution departments, groups, and representatives
- 1.5.1.5 Subcontractors
- 1.5.1.6 Manufacturers, vendors and suppliers as appropriate
- 1.5.1.7 Owner's TAB contractor
- 1.5.1.8 Independent testing labs
- 1.5.1.9 Campus Liaison(s)
- 1.5.1.10 Cx Authority (if appropriate)

1.5.2 Commissioning activities shall be identified, scheduled, executed, documented, and tracked by the Contractor and coordinated with the Owner and Owner-designated consultants, and shall include, but not be limited to:

- 1.5.2.1 Inspections/Tests as required by plans and specifications
- 1.5.2.2 Equipment Startup
- 1.5.2.3 Functional Tests
- 1.5.2.4 Integrated System Testing
- 1.5.2.5 Entire Facility Integration Testing
- 1.5.2.6 Training

1.5.3 Equipment List

- 1.5.3.1 The Contractor shall prepare an equipment list using the approved Commercial Software Solution or the Owner-furnished template form. This list shall contain a complete record of operable equipment, devices, and systems, organized by function and logically grouped with supported/related systems.
- 1.5.3.2 The list shall be populated with all available information for the Cx kickoff meeting. The list shall, as a minimum, include the following data for each item:
 - 1.5.3.2.1 Brief equipment identification text
 - 1.5.3.2.2 Equipment or device ID number (device tag)
 - 1.5.3.2.3 Startup inspection required? (Yes/No)
 - 1.5.3.2.4 Associated building system, (Lighting, Access Control, Life Safety, Building Envelope, Domestic Hot Water, Chilled Water Distribution, etc.)
 - 1.5.3.2.5 Governing specification section
 - 1.5.3.2.6 Installation location
 - 1.5.3.2.7 Area(s) served
 - 1.5.3.2.8 Manufacturer and model number
 - 1.5.3.2.9 Serial number
 - 1.5.3.2.10 Date of the Equipment Startup by the Contractor
 - 1.5.3.2.11 Completion date of Functional Test demonstration by the Contractor
 - 1.5.3.2.12 Completion date of Integrated System Test demonstration by the Contractor (multiple equipment items may be included in a single IST)
 - 1.5.3.2.13 Trending Data required? (Yes/No) Trending data includes loop tuning documentation (log values and graphed) of stable control through a setpoint change.
 - 1.5.3.2.14 Date of Verification of Trended Data (graphical data and tabular logs to be included in the CCR)
 - 1.5.3.2.15 Date of completion of Training
 - 1.5.3.2.16 Systems shall be included at the end of the list for systems that require an IST (not all columns, such as specific equipment-related data will be applicable).
- 1.5.3.3 During construction, the equipment list data shall be continuously updated at regular intervals and provided at each Cx Meeting. The equipment list will be a part of the CCR. Updates should occur at least weekly, and more often as deemed necessary by the Owner.
- 1.5.3.4 The requirement to provide continuous updates to the equipment list for distribution at Cx meetings may be waived with the employment of a commercial Cx software solution that is capable of generating equipment reports that satisfy the intent of the equipment list used as a progress-tracking tool. The aforementioned report shall be provided at each Cx meeting. The

Owner must approve any waiver of the use and maintenance of the equipment list, and reserves the right to reinstate the equipment list requirement.

1.6 COMMISSIONING ACTIVITY DOCUMENTATION REQUIREMENTS

1.6.1 To verify the Cx work, a logical sequence of Cx activity documentation shall be completed by the Contractor and witnessed and reviewed by The Owner (or an Owner-designated consultant). All Contractor installed systems (static and dynamic), subsystems, assemblies, equipment, components and devices shall be tested, operationally verified and documented. The Contractor is responsible to provide Cx forms and testing procedures with appropriate rigor to meet the specific needs of the project. Sequence of operation testing procedures (in an itemized action-response format) shall be contained in applicable FPTs and/or ISTs and the EFIT. The sequence of operation testing procedures shall include testing and demonstration of failure conditions. At a minimum, Cx documentation shall include:

- 1.6.1.1 Pipe/Duct Pressure Test - Contractor shall provide map (plan view) detailing each tested section.
- 1.6.1.2 Construction Checklist (CC) - CCs shall be used to document the condition of equipment upon delivery to the site and appropriate installation for submitted and approved components of a system, i.e., motor installation, waterproofing membrane application, roof application, etc. The manufacturer installation checklist should be completed and attached to the completed CC. (Contractor may implement with Owner approval either their own construction checklists or manufacturer checklists.
- 1.6.1.3 Equipment Startup Checklist (ESC) - Checklist shall be used to document the startup (energizing the equipment) of operable equipment. The purpose of the ESC is to verify and document that equipment is energized and started in accordance with manufacturer recommended procedures, and to coordinate witnessing of the event with the Owner and interested campus entities.
- 1.6.1.4 Functional Performance Test (FPT) - Document containing verification and operational procedures for demonstrating the full functionality and performance of an installed component, equipment or system. FPT procedures shall employ an itemized action-response format.
- 1.6.1.5 Integrated System Test (IST) - The IST documentation shall be used to document demonstration of operational performance of multi-component sequences of operation to include integration with other components, interlocks and alarm conditions for homogeneous systems. Testing procedures are to include all modes of operation and shall employ an itemized action-response format.

- 1.6.1.6 Entire Facility Integration Test (EFIT) - The EFIT shall document demonstration of operational performance and integrated operation of the entire facility as a multi-functioning operational system.
- 1.6.1.7 All FPT, IST, and EFIT documents shall be submitted to the Owner for approval for use no less than 60 calendar days before applicable scheduled activity.
- 1.6.1.8 Other specialized test reports (identified in technical specifications) - Contractor shall submit industry standard or custom forms and report formats as appropriate for approval by the Owner.
- 1.6.1.9 Closeout Documentation Matrix shall include all project deliverables to be transmitted to the Owner prior to substantial completion. Deliverables listed shall include:
 - 1.6.1.9.1 The prescribing specification section
 - 1.6.1.9.2 Description of item(s)
 - 1.6.1.9.3 Type of item to be transmitted (spare parts, attic stock, training, warranties beyond one year, O&M manuals, as-builts, keys checklist, and service contracts)
 - 1.6.1.9.4 Quantities transmitted
 - 1.6.1.9.5 Transmittal date
 - 1.6.1.9.6 Recipient of transmitted deliverable
 - 1.6.1.9.7 Initials of the recipient of transmitted deliverable

1.7 CONTRACTOR'S COMMISSIONING RECORD

- 1.7.1 The CCR is a consolidation of all Cx and testing documentation for the project. The Contractor shall transmit the CCR to the Owner at the conclusion of the project construction phase (Substantial Completion), as agreed upon in writing by the Owner.
- 1.7.2 The Contractor shall employ a commercial software solution to generate and maintain the CCR. A proposed commercial software solution shall be submitted to the Owner for approval.
- 1.7.3 The Contractor is responsible to provide the necessary input/access devices (iOS or Android device) for the Owner to utilize the software solution for the duration of the project. Each assigned construction inspector and the ODR shall receive an input/access device.
- 1.7.4 The Contractor may request that the Owner waive the requirement for the use of a commercial software solution. The requested waiver must include a detailed, project-specific plan for documenting and providing a comprehensive CCR.

1.7.5 The CCR shall include, but not be limited to, the following:

- 1.7.5.1 The Contractor's Cx Plan
- 1.7.5.2 Equipment List Cx Schedule (Duration to include every Cx activity through Substantial Completion)
- 1.7.5.3 Closeout Documentation Matrix
- 1.7.5.4 Commissioning Schedule (final with updates)
- 1.7.5.5 Paint/Finish Schedule

- 1.7.5.5.1 Schedule shall include all paints, wall coverings, flooring, finishes, etc. used on the project.

- 1.7.5.5.2 Provide manufacturer, model #, color formula, location on project, purchase source and any other information helpful to the institution's maintenance personnel.

- 1.7.5.6 Field Observation Reports
- 1.7.5.7 Cx Meeting Minutes
- 1.7.5.8 Building Envelope Inspections and Tests
- 1.7.5.9 Pipe Pressure Tests
- 1.7.5.10 Duct Pressure Tests
- 1.7.5.11 Fire Alarm and Suppression System Tests and Reports
- 1.7.5.12 Completed NFPA Forms
- 1.7.5.13 Commissioned Component/Equipment/System Documentation
- 1.7.5.14 Construction Checklists (w/attachments)
- 1.7.5.15 Equipment Startup Checklists (ESC)
- 1.7.5.16 Functional Performance Tests (w/attachments)
- 1.7.5.17 Integrated System Tests (w/attachments)
- 1.7.5.18 Entire Facility Integration Test
- 1.7.5.19 Owner Training Plans (with sign-in sheets)

1.7.6 Equipment and system submittals, shop drawings, and as-built documentation shall be submitted separately as required elsewhere in the contract documents.

1.7.7 Operating and Maintenance (O&M) Manuals for each system, equipment, and device shall be submitted separately as required elsewhere in the contract documents. An exception to the CCR including the O&M Manuals is made when a commercial software solution incorporates the O&M Manuals as attachments to the Equipment Record and the CCR is being delivered electronically as a packaged output (or export) from the commercial software solution.

1.7.8 Prior to delivering the CCR, Contractor shall schedule and facilitate a meeting to align BAS/HVAC Controls as-built documentation with TAB documentation and (as applicable) 3rd party Cx provider documentation. This meeting should focus on the sequences of operation for all operable equipment and associated control parameters, variables, algorithms and setpoints.

PART 2 PRODUCTS

2.1 TEST EQUIPMENT

- 2.1.1 Subcontractors shall provide all specialized tools, test equipment and instrumentation required to execute startup, checkout, functional performance, integrated systems and entire facility testing that includes equipment under their contract.
- 2.1.2 Test equipment shall be of sufficient quality and degree of accuracy to test and/or measure system performance within tolerances specified. Subcontractors and vendors shall provide calibration certificates for all test equipment and instrumentation. The Contractor, subcontractor or testing laboratory shall use test equipment that has been calibrated within the previous 12 months. Calibration shall be NIST traceable. Test equipment shall be calibrated according to manufacturer's recommended intervals and recalibrated when dropped, damaged, or when Owner deems necessary. Calibration tags shall be affixed or certificates readily available.

PART 3 EXECUTION

3.1 COMMERCIAL COMMISSIONING SOFTWARE SOLUTION

- 3.1.1 The Contractor shall submit for approval by the Owner, a commercial Cx software solution used to generate and collect the CCR and associated Cx activity checklists and procedures, equipment information, associated manuals, photos, etc. in a database format that is COBie compliant, and that employs an issue/deficiency tracking system. The commercial Cx software solution shall provide for customizable systems and equipment types and designations such as, but not limited to, access control systems, security systems, building envelope systems and healthcare systems (nurse call, medical gas, pneumatic tube conveyance, etc.). The Cx Software shall:
 - 3.1.1.1 Provide for online storage of "library" files that can be organized in a customizable folder structure.
 - 3.1.1.2 Include sufficient licensing to accommodate the maximum users necessary to meet the needs of the project, including licenses necessary for Owner's project team. Coordinate with the Owner to determine license quantity requirements. Licenses and access to the Cx software will be required to be maintained for 12 months after Final Completion.
 - 3.1.1.3 Employ security capabilities using industry standard encryption (128-bit minimum) for web-based access and offline device synchronization. The software solution shall employ the use of a unique user ID and password for each individual user. Access and permissions shall be assignable to each unique user ID, or to categories or groupings of users engaged in similar roles. The Cx software shall allow for simultaneous multiple user access to database records

for checklist updates, entry of issues, attachment of photos, access to library files, etc.

- 3.1.1.4 Allow for custom data elements (attributes) associated with each type of equipment (VAV Box, Air Handling Units, Electrical Panels, etc.) that can be configured by the user. Each project must be able to support a unique (user defined) set of data elements specific to the requirements of the project. The system shall provide support for industry standard barcode or QR code for each equipment/system item.
- 3.1.1.5 Provide for checklist generation (creation) with customizable checklist responses. Software shall employ the use of checklist templates to create individual equipment-specific checklists. Software shall provide for auto “Issue Generation” based on user-selected trigger responses. Responses shall include a default “Pass/Fail”, numeric (only) response and user-defined “single item select list” as a minimum.
- 3.1.1.6 Provide for tracking of systems/equipment status as each item progresses through the Cx process. The process (progressive list of statuses) shall be user defined and selectable from a drop-down or “single item select list.”
- 3.1.1.7 Provide for interactive field data entry in either an online or offline environment. The data entry or Cx software remote (field) access device shall be Android and/or iOS compatible. Contractor shall provide (and maintain) Owner with Android or iOS compatible remote access devices for the duration of the project. (Examples are an iPad or tablet PC.) Offline access capability shall support storage of all database items enabling full software functionality. The remote access device shall be capable of storing for offline access contract documents (drawings, specifications, etc.) and software library documents.
- 3.1.1.8 Provide browser-based access to the online database via the internet using current industry standard browsers (e.g., Chrome, Fire Fox, Internet Explorer, Edge or Safari). Browser-based access must be fully compatible with a minimum of two of the listed industry standard browsers.
- 3.1.1.9 The use of any software that does not comply with each of the requirements listed above or use of an alternative methodology of generating/collecting/documenting the CCR shall require a written substitution proposal that includes samples of each tracking tool and document type (checklist, report, equipment tracking, etc.) that will be included in the CCR. Substitution proposals must list each criterion in Section 3.1 and designate compliance or detail specific non-compliance. Substitution proposal shall be submitted prior to Contractor’s Notice to Proceed (NTP) for project construction phase.

3.2 COMMISSIONING SCHEDULE

3.2.1 The objective of scheduling Cx process activities is to integrate and coordinate Cx activities with other construction phase activities. Detailed scheduling will allow Cx Team members to coordinate work with other team members in order to complete all Cx activities prior to Substantial Completion. The Cx Schedule shall include major Cx activities, essential prerequisites for major equipment and system activities and operable equipment/system/assembly functional and integrated systems performance demonstrations. The Cx Schedule shall account for Test and Balance (TAB) consultant activities properly scheduled and coordinated into the project work flow to allow for the completion of all TAB work prior to Substantial Completion. The Cx Schedule shall account for building envelope consultant inspections, tests and other activities properly scheduled and coordinated into the project work flow to allow for inspections and testing prior to covering or concealment. As applicable, the following milestones and activities shall be incorporated into the project master construction schedule:

- 3.2.1.1 Cx Kickoff Meeting
- 3.2.1.2 Building Automation System Submittal Approval
- 3.2.1.3 Control Sequence of Operation Coordination Meeting (reference Specification Section 23 05 93A)
- 3.2.1.4 Ethernet Connectivity
- 3.2.1.5 Building Envelope Testing and Verification Activities
- 3.2.1.6 Major HVAC Equipment/Systems Startup
- 3.2.1.7 System Specific Test and Balance Activities
- 3.2.1.8 Major HVAC Equipment Functional Performance Tests
- 3.2.1.9 Integrated System Tests
- 3.2.1.10 Entire Facility Integration Test
- 3.2.1.11 Training

3.2.2 The Contractor shall provide a minimum of 72 hours' notice prior to each Cx activity to the Owner and the CxA and Testing Consultants when applicable, unless stipulated otherwise in this specification or other technical specifications.

3.3 COMMISSIONING KICKOFF MEETING

3.3.1 Within 120 days after the effective date of the NTP for the construction scope or package that includes building operational systems, the CxC will schedule a date to conduct a Cx kickoff meeting with all parties involved in the Cx process. As a minimum the meeting should include the major subcontractors, specialty manufacturers/suppliers, the A/E, mechanical and electrical consultants, the Owner's testing, adjusting and balancing (TAB) firm, the CxA, the Owner and representatives from the UT institution.

- 3.3.1.1 The Contractor shall prepare for the meeting by creating drafts of the following documents for review at the meeting:
 - 3.3.1.1.1 The Cx Plan
 - 3.3.1.1.2 Equipment List
 - 3.3.1.1.3 Closeout Documentation Matrix
 - 3.3.1.1.4 The Cx Record - Table of Contents
 - 3.3.1.1.5 An overview or demonstration of the approved Cx software
 - 3.3.1.1.6 Sample ESCs and FPTs
 - 3.3.1.1.7 Preliminary Cx Schedule incorporating Cx activities to coincide with the work flow contained in the master construction schedule
- 3.3.1.2 The Contractor shall conduct the meeting and review the Cx process and specifications, including discussion of documentation requirements, available test procedures and Cx forms.
- 3.3.1.3 The Cx Plan review shall outline roles and responsibilities of each Cx team entity and the potential schedule impact as related to Cx requirements.
- 3.3.1.4 The CCR Table of Contents review shall include discussion of the scope of work. The Contractor shall be prepared to distribute copies of the pertinent document samples to the subcontractors involved in the Cx process.
- 3.3.1.5 The Cx Schedule review shall include the dates and durations for major systems startup, and shall identify functional performance testing that is included in the master construction schedule. Team members should identify potential schedule impact pertaining to their scope of work and test sequencing.
- 3.3.1.6 Commissioning shall be an agenda item for project progress meetings until separate Cx meetings are deemed necessary.

3.4 PRE-INSTALLATION MEETINGS

- 3.4.1 At a minimum, the Contractor shall schedule a separate meeting for the work involving each major building system or systems and assemblies. The pre-installation meeting shall be scheduled, in writing, a minimum of five (5) days in advance, and shall be scheduled so that the Owner, Owner-designated consultants and Architect/Engineer can attend. The meeting shall be convened following approval of system submittals and prior to commencement of system installation work.
 - 3.4.1.1 The Contractor shall arrange for all subcontractors, suppliers and manufacturers involved in the system to be present or adequately represented.

- 3.4.1.2 The Contractor shall bring the following to this conference, at a minimum, for review and discussion:
- 3.4.1.2.1 The portion of the equipment list applicable to the system/trade under discussion
 - 3.4.1.2.2 Current work schedule data pertaining to the equipment delivery, installation, required testing, construction checklists, equipment startup and functional performance testing anticipated
 - 3.4.1.2.3 Copy of all approved submittals for the system
 - 3.4.1.2.4 Draft of documentation/checklists to be used for inspection, startup and functional performance testing of the system(s)/assembly under review.
- 3.4.1.3 The purpose of this meeting is for the Contractor and all applicable subcontractors and/or suppliers and/or factory representatives to discuss all aspects of the installation of the particular system, testing and documentation required and procedures to be followed. Special attention is to be directed to the scheduled order of work and any impact on or by any other building systems.
- 3.4.1.4 The Contractor shall demonstrate the commercial Cx software and use of remote access device. An explanation of the use and protocols that will be employed should accompany the demonstration. This is not intended to be a training session; it is a demonstration for familiarization purposes.
- 3.5 CONTRACTOR'S VERIFICATION OF INSTALLATION – CONSTRUCTION CHECKLIST
- 3.5.1 The Contractor shall document using a construction checklist a review of testing/inspection forms to ensure each is accurate and complete. This documentation shall include, but not be limited to, first-hand knowledge of the following items:
- 3.5.1.1 Equipment/system is delivered in new condition and in accordance with approved submittals. Delivered equipment and materials are protected, staged and stored in accordance with the specifications and the manufacturer recommendations.
 - 3.5.1.2 Each component device has been installed and terminated in accordance with the project specifications and governing codes as well as the manufacturer's written recommendations.
 - 3.5.1.3 All shop drawings and product data submittals have been approved for each component device.

- 3.5.1.4 All valve schedules, wiring diagrams, control schematics, electrical panel directories, etc. have been submitted, approved, and equipment/systems installed in accordance with specifications.
- 3.5.1.5 All test reports and/or certifications required have been submitted and accepted. If required, certificate of acceptance from manufacturer representative and/or engineering technician have been received. Provide copies of all checklist/inspection documentation completed by the manufacturer or certified technician.
- 3.5.2 The Contractor shall be responsible for correction of all noted deficiencies. Any request for inspection/re-inspection or test/retest of a device or system shall first be confirmed as being compliant by the Contractor before submitting a request to the Owner for inspection/re-inspection and testing/retesting.
- 3.6 EQUIPMENT STARTUP
 - 3.6.1 Startup of Independent Systems, Assemblies, Components and Devices
 - 3.6.1.1 Equipment startup is a documented formal Cx activity for the Owner (and others) to verify and witness proper startup in accordance manufacturer recommendations and contract documents. The Contractor shall utilize the Equipment Startup Checklist (ESC) to document the activity, participants, and witnesses.
 - 3.6.1.2 The Contractor shall not energize or activate, or allow activation of any operable device prior to equipment startup by a manufacturer representative. It is NOT permissible to “bump” motors prior to equipment startup. Contractor shall verify proper electrical service wiring (phasing) with the use of a phase rotation meter.
 - 3.6.1.3 The Contractor and manufacturer’s representative shall inspect and accept the installation and preparedness for startup. The Contractor shall execute startup under supervision of a responsible manufacturer's representative in accordance with manufacturer's instructions and as specified in the contract documents. The installation shall not vary from provisions of the applicable specifications and the manufacturer's written recommendations for startup. The Contractor shall develop and use the ESC to document (for the CCR) preparedness for startup, startup procedures and record operational measurements and data appropriate for the equipment and in accordance with the technical specifications. The Contractor is encouraged to incorporate any manufacturer provided installation and startup checklists as part of the ESC.
 - 3.6.1.4 The Contractor shall provide five (5) business days’ notification of scheduled equipment startup to the Owner, the Owner’s designated consultants and the A/E team.

3.7 FUNCTIONAL PERFORMANCE TESTING

- 3.7.1 After all relevant Construction Checklists are completed and startup has been accomplished, the Contractor shall coordinate pre-functional testing by the subcontractors and applicable Owner consultants in preparation for the Functional Performance Test (FPT). Contractor shall provide five (5) business days' notice of the scheduled FPT (demonstration) to the Owner, Owner designated consultants and A/E team.
- 3.7.2 The Demonstration of an FPT is a documented formal Cx activity for the Owner (and others) to verify the operation of equipment/assembly/system in accordance with contract documents to include all modes of operation, sequences of operation and anticipated failure conditions. The Contractor shall operate, or cause to be operated, each system, device, assembly or equipment item, both intermittently and continuously, for the duration indicated in the specification section(s) for such item and/or in accordance with the manufacturer's written recommendations, and in accordance with the approved FPT procedures. The details of these activities shall be documented for the CCR. The Owner and/or an Owner-designated consultant shall witness and verify the results of the functional performance test demonstration.
- 3.7.3 For operable equipment/systems, each component device and each building system shall be exercised to the full extent of its capability, from minimum to maximum, under automatic and manual control, and in bypass when applicable. The equipment/assembly/system shall be exercised using the Campus BAS graphics on a campus operator's workstation. All inputs, outputs and calculated values, as displayed on the operator's workstation graphics, shall be verified and documented.
- 3.7.4 The Contractor and, when applicable, manufacturer's representative, shall supervise and coordinate adjustments, alignments, calibrations and balancing of all devices, equipment and systems for proper operation as part of the pre-functional testing activities.
- 3.7.5 The Contractor shall coordinate with the Owner's consultants to support the progression and completion of their scope of work. The Contractor shall provide the TAB firm and envelope consultant with installation and performance data as requested by the consultant (and approved by the Owner).
- 3.7.6 For Static systems, periodic observations shall be documented in accordance with manufacturer installation guidelines and recommendations. Performance testing as recommended by the manufacturer and in accordance with applicable technical specifications requirements shall be documented.
- 3.7.7 Where final TAB of a system or particular components thereof are not specifically indicated to be performed by Owner or Owner's consultants, the Contractor is to

provide final balancing and adjustments for operation within specified tolerances and provide documentation of it prior to scheduled FPT of each system.

3.8 INTEGRATED SYSTEM TESTING

- 3.8.1 After successful completion and documentation of all system/assembly/equipment FPTs, the Contractor shall schedule a meeting with the Project Cx Team to review the approved Integrated System Tests (ISTs) and demonstration procedures for each designated system. An integrated system contains two or more system components that have been functionally tested and have physical, hardwired or software interfaces that require one component to respond as the result of the operation of one or more other components. Examples of a few systems that would require an IST are: chilled water distribution, domestic hot water system, primary electrical distribution, fire alarm, access control and security systems.
- 3.8.2 Development of IST and demonstration procedures may vary with each project. The Contractor is responsible for providing ISTs that include all modes of operation for the system that could act upon or react to operation of separate system components. An IST shall be submitted to the Owner for review and comment and final approval by the A/E team. Collaboration with the A/E design team during IST development will ensure that a thorough performance demonstration is achieved. ISTs shall include a comprehensive, action-response checklist for all modes of operation and failure conditions included in the sequence of operation and shall itemize for each action, the anticipated response from each integrated system and/or associated component.
- 3.8.3 Following compliance with the provisions noted above and following submission of Operating & Maintenance (O&M) Manuals for the all systems to be demonstrated, the Contractor shall provide the Owner a five (5) business day notice of their intent to perform an IST demonstration. The Contractor is responsible for documenting the results of the ISTs.

3.9 ENTIRE FACILITY INTEGRATION TESTING

- 3.9.1 After successful completion and documentation of all ISTs, the Contractor shall schedule a meeting with the Project Cx Team to review the Entire Facility Integration Test (EFIT). The EFIT is a facility-wide test to verify that all building systems interact and predictably perform in accordance with the design documents.
- 3.9.2 Development of the EFIT and demonstration procedures shall be a collaborative effort of the Cx Team facilitated by the Contractor. The Contractor is responsible for ensuring that all building systems are included in the EFIT, that each system responds to designed modes of operation, and that anticipated failure conditions are itemized for monitoring and verification. The format of the EFIT testing procedures shall be an action-response matrix that identifies for each action (mode of operation), the itemized list of responses that are to be verified and documented. The Contractor shall submit the EFIT to the Owner and A/E team for review and comment.

- 3.9.3 Following compliance with the provisions noted above, the Contractor shall provide the Owner a five (5) business day notice of their intent to perform an EFIT. The Contractor is responsible for documenting the results of the EFIT.

3.10 OWNER TRAINING (insert training hours required table)

- 3.10.1 Training shall consist of classroom type sessions and on-site demonstrations of system operation. See specification technical sections for specific system/equipment requirements. If a system/equipment requires both field demonstration and training, they may be combined if the Owner approves.
- 3.10.2 The Contractor shall provide a professional-grade video recording of training, with audio, in accordance with the technical specifications. The Owner will select those portions of the training to be recorded.
- 3.10.3 The Contractor shall be responsible for submitting individual training plans and for coordination, scheduling and completion of the training for all equipment as specified in the contract documents. The training will be conducted by the installing subcontractor and/or manufacturer's representative for each specific piece of equipment in accordance with the applicable technical specification sections. Each training plan shall be submitted to the Owner no later than 14 calendar days in advance of proposed training. Training plans shall include the specifications section reference, proposed trainer and relevant qualifications (resume), training agenda with learning objectives, copies of training materials/handouts/visual aids, training date, time, location and duration.
- 3.10.4 Training shall use the O&M Manuals as a basis for instructing the Owner's personnel regarding system operation. Training shall include a review of the contents of O&M Manuals and a review of equipment data and performance verification from the FPT checklists.
- 3.10.5 Demonstrate in the field: startup, operation, control, adjustment, trouble-shooting, servicing, maintenance, each component device and shutdown of the system(s).
- 3.10.6 Demonstrate both in the field and with the use of operator (workstation) graphics a detailed check-out at each stage of the sequences of operation. All equipment graphics, alarms and sequences of operation are to be reviewed, and demonstrated to the extent the Owner agrees is feasible.
- 3.10.7 The Contractor shall participate in demonstration of Owner Furnished/Contractor Installed equipment in accordance with applicable technical specifications.

3.10.8 As a minimum, the Contractor shall perform training on all Life Safety systems including, but not limited to, the following (if system is part of the project):

- 3.10.8.1 HVAC and Controls
- 3.10.8.2 Fire Alarm
- 3.10.8.3 Fire Sprinkler Systems (including pumps)
- 3.10.8.4 Elevator/Escalator
- 3.10.8.5 Smoke Purge
- 3.10.8.6 Stairwell Pressurization
- 3.10.8.7 Communications Systems
- 3.10.8.8 Emergency Power/Generator/UPS
- 3.10.8.9 Alternative Energy/Energy Recovery Systems
- 3.10.8.10 Facility Security System
- 3.10.8.11 Medical Gas Systems
- 3.10.8.12 Security/CCTV/Access Control/Article Protection Systems

End of Section 01 91 00



The University of Texas
Health Science Center at Houston

REVISION LOG

The following is provided for convenience to the Owner, Architect/Engineer and Contractor to track changes between annual document issuances and is not to be considered by any party to be contractual or 100% complete.

Date	Items Revised
9/17/19	Original Document



The University of Texas
Health Science Center at Houston

SECTION 10 14 16.11 - CAST BRONZE DEDICATORY BUILDING PLAQUE

PART 1 - GENERAL

1.01 RELATED DOCUMENTS

- 1.01.1 Bidding and Contract Requirements, and Division 1, General Requirements, are hereby made a part of this section.

1.02 DESCRIPTION

- 1.02.1 Work Included: Furnish and install one (1) cast bronze (or cast aluminum if preferred by Owner) plaque complete.

1.03 SUBMITTALS

- 1.03.1 UTHSCH will provide a detailed layout of the plaque.
- 1.03.2 Submit four copies of a full size shop drawing directly to UTHSCH for approval prior to casting.
- 1.03.3 UTHSCH will return two copies of the approved shop drawing to the contractor.

1.04 PRODUCT DELIVERY, STORAGE AND HANDLING

- 1.04.1 Deliver plaque crated to provide protection during transit and job storage.
- 1.04.2 Inspect plaque upon delivery for damage and correctness.
- 1.04.3 Store plaque inside building.

1.05 JOB CONDITIONS

- 1.05.1 Building shall be enclosed and in the dry. Coordinate installation with work of other trades.

PART 2 - PRODUCTS

2.01 CAST BRONZE PLAQUES (Alt. CAST ALUMINUM)

- 2.01.1 Plaques shall be as manufactured by The Southwell Company, P.O. Box 299, San Antonio, Texas 78291, or approved equal. Tablet shall be cast of virgin ingots (85-5-5-5 Standard U. S. bronze alloy, or, aluminum alloy 356.1). Casting shall be free of pits and gas holes and all letters shall be sharp and hand tooled. Border and faces of raised letters shall be satin/brushed finish and background shall be leatherette finish. Plaque shall be chemically cleaned and etched and treated with Alodine and sprayed with two coats of Clear Acrylic Lacquer.

- 2.01.2 Size: 36" W x 24" H.
- 2.01.3 Border Design: Raised, satin/brushed finish.
- 2.01.4 Letter style: "Seneca," satin/brushed finish.
- 2.01.5 Background: Leatherette finish, Oxidized-Dark Bronze or Black (if aluminum).
- 2.01.6 Text: Include Building Name, Year of Notice to Proceed, Names of Board of Regents at issuance of Notice to Proceed, and Names of Architect and Prime Contractor, etc. For Bidding Purposes, assume 60 large characters and 375 small characters. Owner shall provide exact wording at a later date.
- 2.01.7 Refer to the attached drawing.

PART 3 - EXECUTION

3.01 INSPECTION

- 3.01.1 Installer must examine the area and conditions under which plaque is to be installed and notify A/E in writing of conditions detrimental to proper and timely completion of work. Do not proceed with the work until unsatisfactory conditions have been corrected in a manner acceptable to the Installer.

3.02 INSTALLATION

- 3.02.1 Install plaque plumb level and square, in proper planes with related surfaces, with concealed type fastening devices.

3.03 CLEAN UP

- 3.03.1 Clean up all debris caused by the work of this Section, keeping the premises clean and neat at all times.

END OF SECTION 10 14 16.11

DRAWN BY: DATE: REASONS:	OFPC THE UNIVERSITY OF TEXAS SYSTEM OFFICE OF FACILITIES PLANNING & CONSTRUCTION TELEPHONE: (512) 499-4600 FAX: (512) 499-4604 210 W 6th St, Austin, Texas 78701
	SHEET 1 OF 2

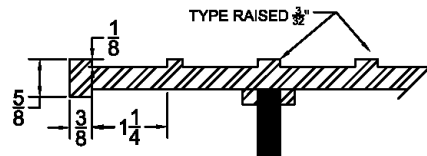
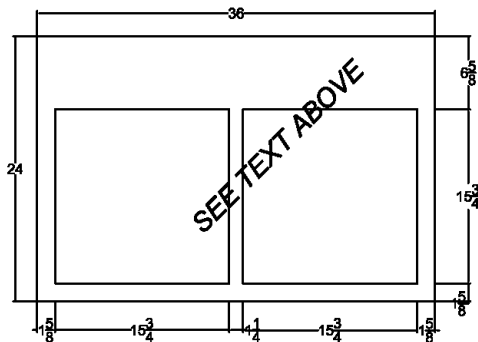
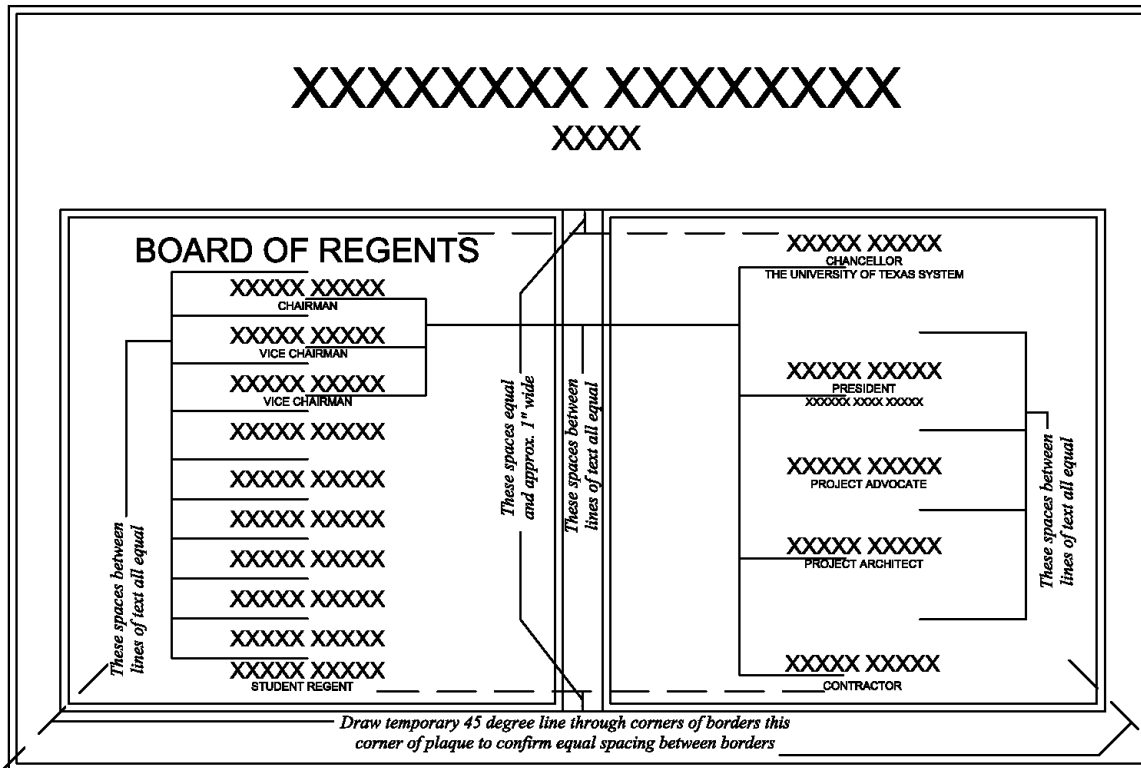

TYPICAL LAYOUT

MATERIAL: CAST BRONZE OR CAST ALUMINUM

BORDERS: SATIN/BRUSHED FINISH

LETTERING: SENECA STYLE; SATIN/BRUSHED FINISH

BACKGROUND: LEATHERETTE FINISH (OXIDIZED DARK BRONZE OR BLACK)

ADDITIONAL REQUIREMENTS IN SPECS.

PLAQUE MANUFACTURER TO RECEIVE DIVISION 10 PLAQUE SPECIFICATIONS FROM CONTRACTOR AND THEN TELEPHONE THE O.F.P.C. MANAGER PRIOR TO STARTING ANY WORK.

DRAWN BY: DATE: REASONS:	OFFPC THE UNIVERSITY OF TEXAS SYSTEM OFFICE OF FACILITIES PLANNING & CONSTRUCTION TELEPHONE: (512) 499-4600 FAX: (512) 499-4604 210 W 6th St, Austin, Texas 78701	SHEET 2 OF 2
--------------------------------	--	---

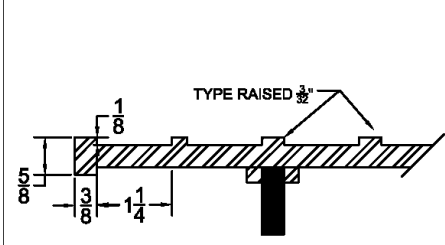
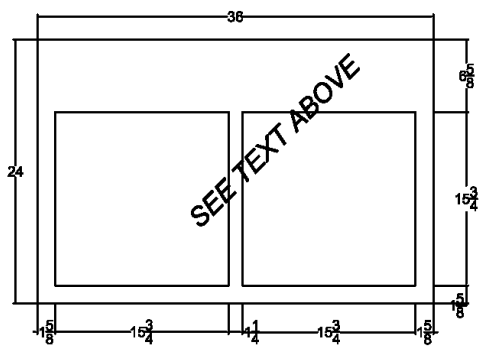
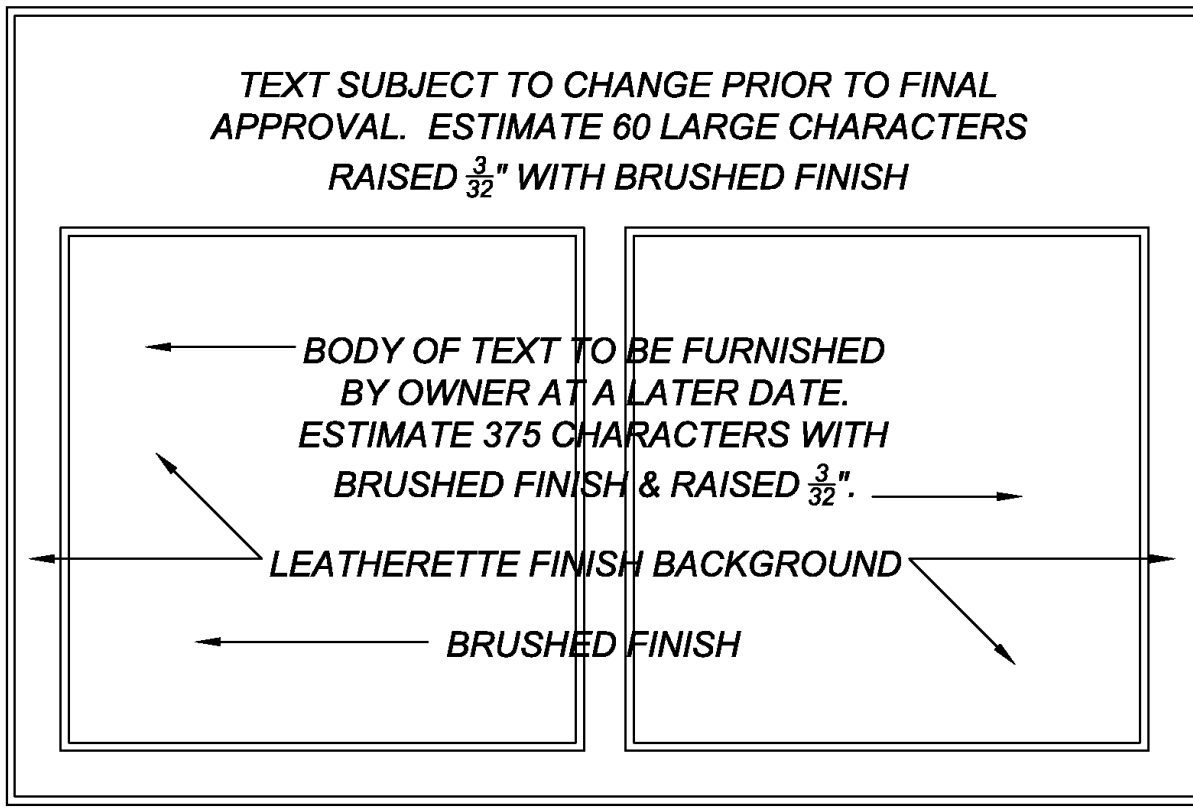

TYPICAL LAYOUT

MATERIAL: CAST BRONZE OR CAST ALUMINUM

BORDERS: SATIN/BRUSHED FINISH

LETTERING: SENECA STYLE; SATIN/BRUSHED FINISH

BACKGROUND: LEATHERETTE FINISH (OXIDIZED DARK BRONZE OR BLACK)

ADDITIONAL REQUIREMENTS IN SPECS.

PLAQUE MANUFACTURER TO RECEIVE DIVISION 10 PLAQUE SPECIFICATIONS FROM CONTRACTOR AND THEN TELEPHONE THE O.F.P.C. MANAGER PRIOR TO STARTING ANY WORK.



The University of Texas
Health Science Center at Houston
REVISION LOG

The following is provided for convenience to the Owner, Architect/Engineer and Contractor to track changes between annual document issuances and is not to be considered by any party to be contractual or 100% complete.

Date	Paragraph Revised
10/06/16	Revised text under 2.01.6; “Project Name” now reads “Building Name” “Year Contract Awarded” now reads “Year of Notice to Proceed” “Names of ... General Contractor” now reads “Names of ... Prime Contractor” “350 small characters” now reads “375 small characters” Revised layout plan to add names for Student Regent and Project Advocate, and Added a second layout drawing showing the spacing requirements for names Revised specification to include cast aluminum as an alternate plaque material